



Choose new unique our cabins design or lets create a new one together!



Contents

About us	1-5
Shed/storage cabins	6-27
Gable roof	8-17
Shed roof	18-20
Flat roof	21-23
Hip roof	24-25
Garden cabins	28-63
Gable roof	30-57
Flat roof	58-61
Home office/studio	64-71
Summer house/chalet	72-91
20-40 m ²	74-77
40-60 m ²	78-87
60+ m ²	88-90
Villa/country house	92-113
1 story	94-103
2 story	104-111
Garages&carports	114-123
Garage	116-119
Carport	120-122
Pergolas	124-131
New concept	132-135
Optional products	136-141
Windows&doors	142-159

About

We produce and exports standard and individual design wooden houses for customers in 20 countries. 15 years of active operation gives us confidence and experience to offer high quality products and services to our customers.

All our houses are made of kiln dried pine and spruce. Production process involves several stages of wood processing and preparation for final inspection and packing. Houses we produce are completely finished in factory and requires no extra processing.



We take responsibility for protecting human life and the environment across our operations. Our company works according to highest quality and safety standards and is committed to responsible and sustainable corporate governance.

Our main business standards are:

- Business with Integrity
- High quality and Safe product
- Corporate Diligence
- Health and Occupational Safety
- Human Rights and Social Standards
- Environmental Protection
- Data Protection and Intellectual Property

In our production we use modern technologies and mechanisms to make sure that materials, resources and human labour are handled in the best possible way. We invest our time and resources to achieve higher efficiency and avoid errors in production.



Joy of spending time outside

Spending time in green space or bringing nature into your everyday life can benefit both your mental and physical wellbeing. For example, doing things like growing food or flowers, exercising outdoors have lots of positive effects - improve your mood, make you feel more relaxed. Some feel better just by going outside to the garden, and some of us need to go away to the countryside to change our everyday surroundings. There's something about the quiet calm of nature that is contagious, leaving a quiet calm in our mind.

Cabin in your garden or summerhouse in countryside is a great option for many of us. It becomes a place we cherish, look after and embellish. It also become extension of our home where we can cultivate our hobbies, exercise or free our creative energy.

We join you on dreams of making your relaxing space more pleasant, more lively, more comfortable and stylish. We offer a possibility to make your dreams come true, to build wooden structures which will make your garden peaceful getaway to hide from modern life rush.

Wooden garden houses and summer houses offer enjoyable advantages in terms of comfort, climate as well as health or environment. Flexible, resistant, light and durable, wood is suitable for most of the grounds and constructions. Wood prevents dust circulation and static electricity, so wooden interior is easy to maintain. The humidity level is naturally low. A wooden house will make benefit from a healthy, comfortable and balanced interior.

We are always happy to see customers appreciating wooden structures and valuing it's benefits.

From small cabins for those who just want to bring order to their garden, to garden houses for you as relaxing, working, meditating and crafting space, or big summer houses and villas, where you can spend weekends and holidays with family and friends.

Let fantasy carry you away to a perfect leisure space and invite Sodnamis© to join you for making it a reality.



What will you find in our catalogue

Dear customer, all our team is working constantly on developing new models and constructional ideas for houses of all sizes and purposes. We strive to meet newest trends in garden and houses design, also follow the movements of public feeling of sustainability, ecology, minimalism and healthy life style. That is why we offer big range of standard models to meet customers' needs at the best possible price.

In this catalogue you will find wide range of garden sheds/storage cabins of different designs, which are created for modern or classical style garden. Sheds are grouped according to roof type (which usually defines shed's style). We offer these types of roofs: gable roof, shed roof, flat roof and hip roof. Shed/storage cabin internal area can vary from 2 to 14m² to meet owners needs of different size gardens or yards. Some sheds are offered with 2 separate rooms, with possibility to use it for different purposes.

Next category is our standard garden houses/log cabins. A large range of log cabin in several wall thickness and designs add extra living space to home with a versatile garden room. These cabins can serve different purposes from storage to pool houses. In the catalogue garden houses are grouped according to roof type: gable roof, shed roof and flat roof. Sizes varies between 12 and 40 square meters of internal area.

A newest addition to our standard range is home offices/studios. Working from home is the new normal these days. Nearly everyone has made unique adjustments to their personal and professional lives. A separate office is a great addition to your home if you're required to work remotely and want the benefit of physically and mentally "leaving" work at the end of the day. Or maybe you want a separate home office to work on projects or hobbies during off-hours and would benefit from the additional space.



A dedicated work space in your home helps you set aside household distractions and focus on work. Our team offers a range of modern and classic looking home offices of various sizes, which can fit different outside spaces. Our team designed these houses to be spacious and cozy to offer customers more natural light and productive environment.

Next categories in our standard range are summer houses and villas. Wooden houses are an increasingly popular and much-loved alternative for a healthier, ecologically-balanced, and organic living. Prefabricated wooden villas are great solution for country house or even living house, as they can be of different sizes and layouts. These houses can be easily insulated and adjusted for colder seasons. Our team offer a wide range of summer houses and villas, which are categorized by size and layouts. To make search in catalogue easier we divided house sizes to these groups: 20-40 m², 40-60 m², 60+ m² and more, also 1 story and 2 stories houses.

We offer a range of wooden garages and carports, which are one of the fastest and easiest way to build. Garages can be supple in full set with wooden or metal garage gates. Carports have different options of parking space and some of the models have separate storage room for even more practical use.

In the catalogue you will also find a range of gazebo and pergolas. Our range of wooden gazebos and pergolas features many styles and designs. We offer different roof styles so that customers could easily adapt the gazebo/pergola to the design of existing structures.

Also, in our catalogue you will find section with our new concept models. By linking up creative minds and ideas with constructors we seek to find more solutions and options of using wood. The wood is now highly fashionable building material. It is ecological, natural, durable and has survived the test of time. By introducing new and innovative technologies, we always look for sustainable alternatives to provide with new concepts. Housing market of the future requires flexibility and an eye for detail. We are proud to have a team who is always interested in moving forward and offering new solutions.



Ideasplanner.com ©

Do you have a unique design and are you looking for a partner to bring this design to life? The Bespoke House is a one-of-a-kind dwelling that meets the individual needs and tastes of the client and the particular demands of the site.

We developed a first in the market on line tool for designing the house with instant price calculation. Ideasplanner© is a No 1 online configurator of bespoke log cabins, summer houses, villas or sheds. A bespoke home is designed specifically to your unique needs, dreams, and specifications. Ideasplanner© provides its user possibility of choosing different types of wood thickness, roof style, windows and doors and many other technical features which makes our configurator very convenient and versatile. Our configurator has user friendly interface and is made for intuitive use. We constantly work on developing our configurator to offer even more options and possibilities. Using Ideasplanner© clients are welcome to personalize their wooden house and we make this experience easy, creative and pleasant.

Discover Our Configurator!



www.ideasplanner.com

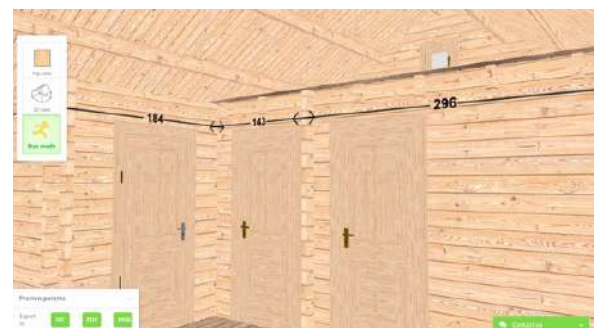
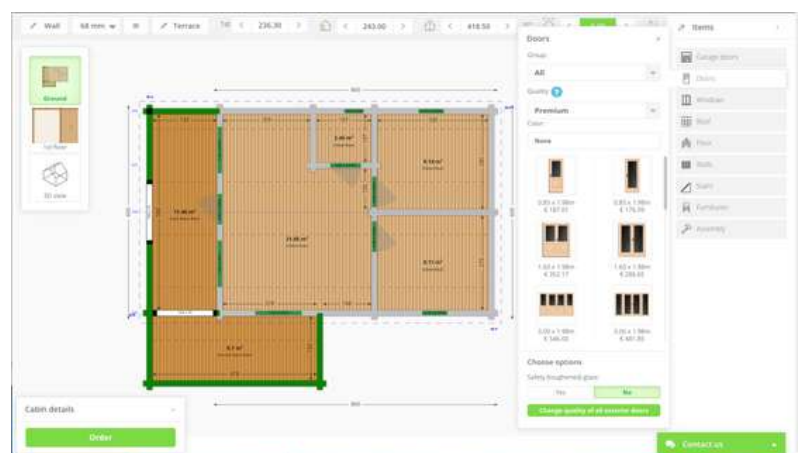
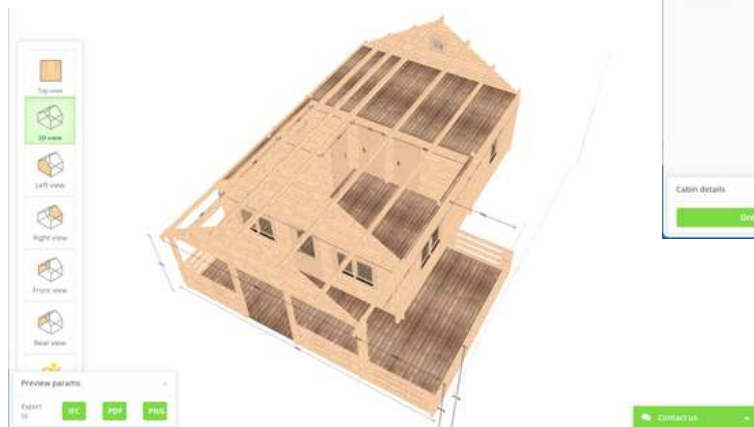
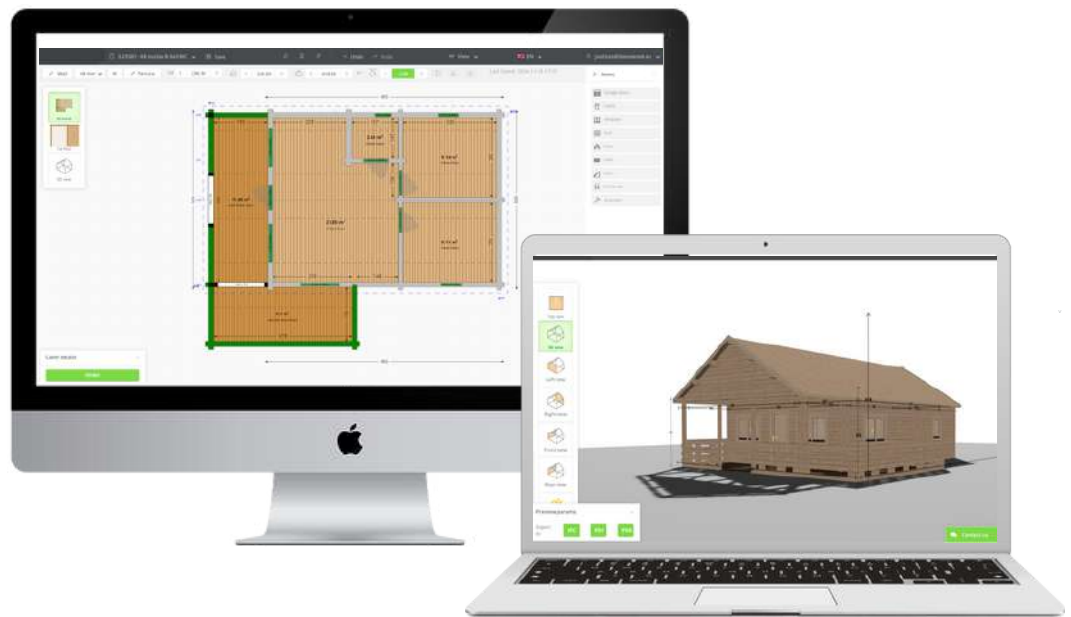

Shed/storage cabins



Gable roof



Shed roof



Flat roof



Hip roof

Gable roof p.8-17



Alva 3x3 p.8



Alva 3x4 p.8



Alva 4x3 p.9



Alva 4x4 p.9



Atlanta 3,56x2,2 p.10



Bedford 2,2x2,2 p.10



Bedford 2,2x3 p.11



Elise 3x5,9 p.11



Emma 3x3 p.12



Emma 4x3 p.12



Erna 2,5x3,4 p.13



Genova 3,8x3 p.13



Imperial 3x3 p.14



Kiosk 3x3 p.14



Kiosk 4x4 p.15



Mantova 2,5x2 p.15



Megy 2,6x4,1 p.16



Modena 3x2,5 p.16



Osaka 3,2x3,2 p.17

Shed roof p.18-20



Bogota 2,5x4 p.18



Edith series p.19



Lima 4,5x3 p.20



Toronto 3x3 p.20

Flat roof p.21-23



Dalas 2,6x2,6 p.21



Eric 3,3x7,36 p.21



Lulu-1 2,4x1,2 p.22



Lulu-2 2,4x2,4 p.22



Lulu-3 3,4x3,4 p.23



Madrid 2,14x2,15 p.23

Hip roof p.24-25



Amarillo 3x5,96 p.24



Colombo 2,6x2,6 p.24



Lukně 3x3 p.25



Rita 3x4,4 p.25

Alva 3x3

Article No. S26905

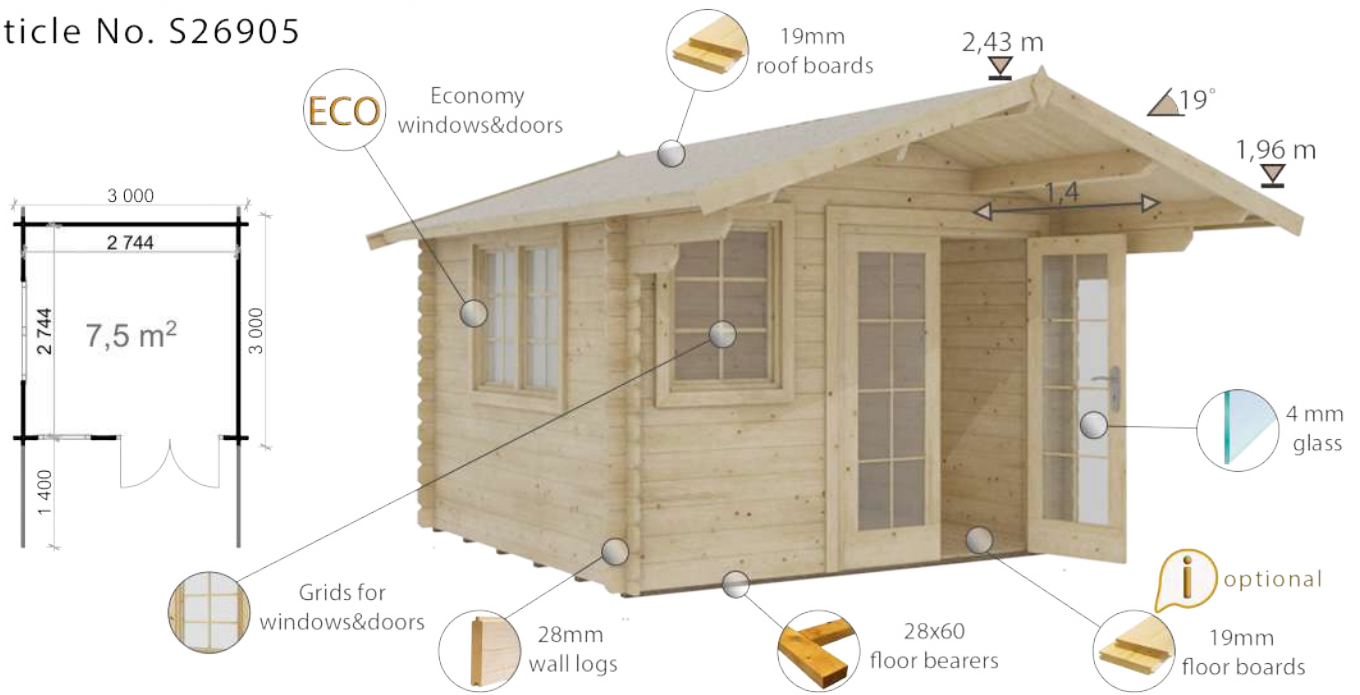

Project specification:

External measures: 3x3 m
Base footprint: 2,8x2,8 m
Internal house area: 7,5 m²
External wall area: 23 m²
Roof area: 16m²

Windows and doors:

Door: 1 double 100% glass 1,85x1,4 m
Window: 1 single 0,92x0,7 m and 1 double 0,92x1,3 m
Threshold: covered with steel

Total height < 2,5 m:

Possible reverse montage:

Installation kit:

Storm braces:

*See optional products pages 26-27

Alva 3x4

Article No. S26199

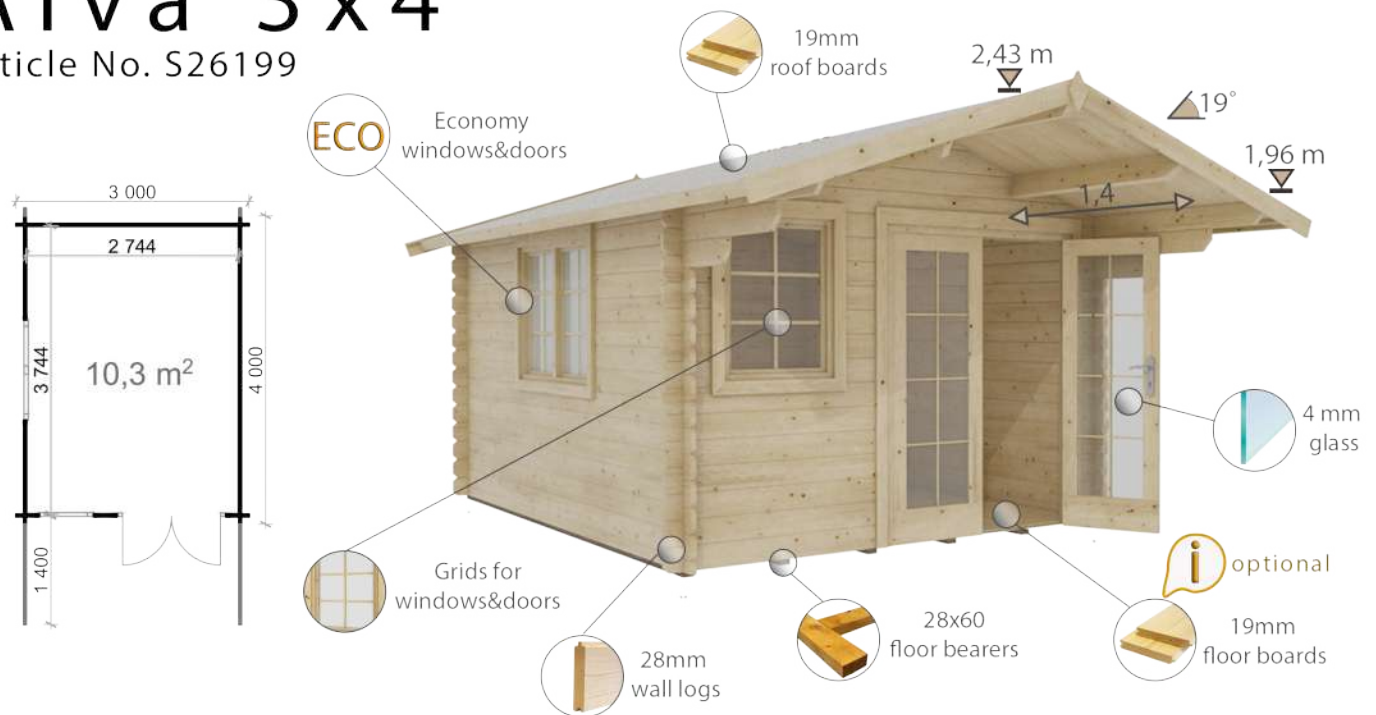

Project specification:

External measures: 3x4 m
Base footprint: 2,8x3,8 m
Internal house area: 10,27 m²
External wall area: 27 m²
Roof area: 19 m²

Windows and doors:

Door: 1 double 100% glass 1,85x1,4 m
Window: 1 single 0,92x0,7 m and 1 double 0,92x1,3 m
Threshold: covered with steel

Total height < 2,5 m:

Possible reverse montage:

Installation kit:

Storm braces:

*See optional products pages 26-27

Alva 4x3

Article No. S26600

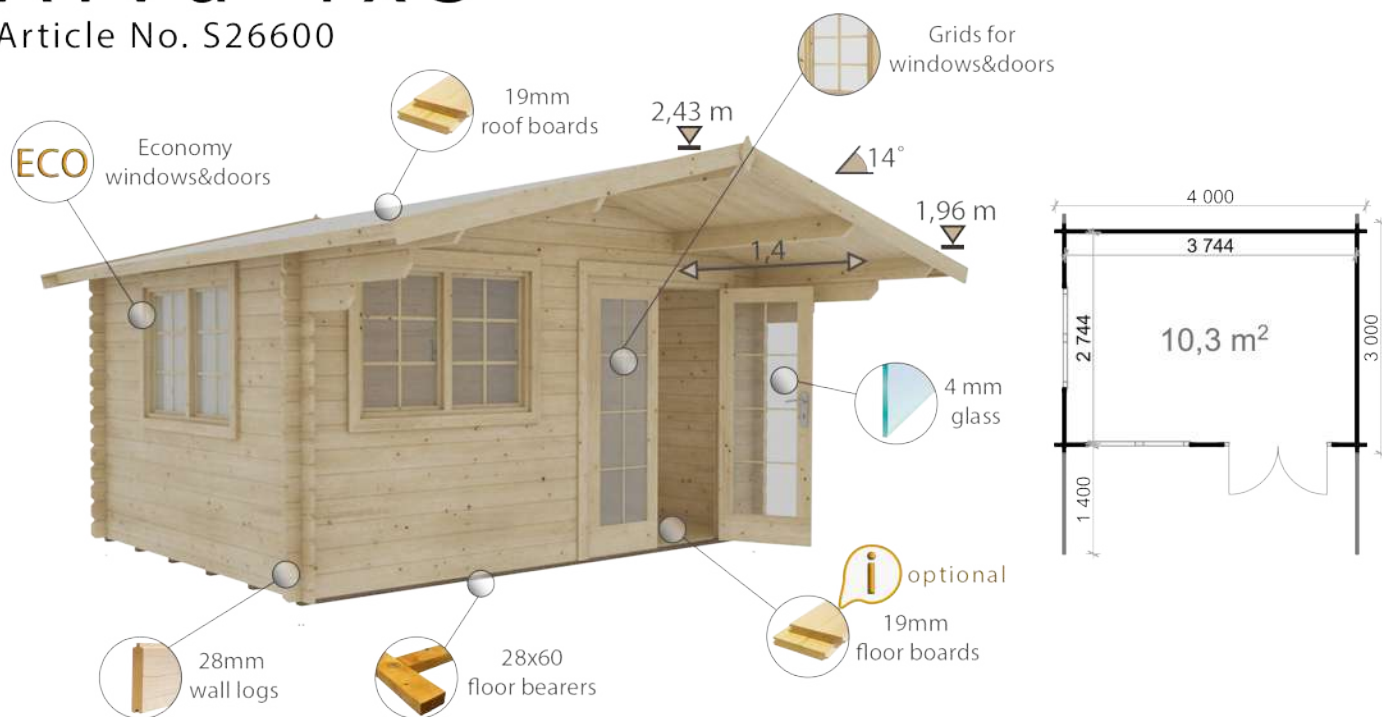

Project specification:

External measures: 4x3 m
Base footprint: 3,8x2,8 m
Internal house area: 10,3 m²
External wall area: 27 m²
Roof area: 20 m²

Windows and doors:

Door: 1 double 100% glass 1,85x1,4 m
Window: 2 double 0,92x1,3 m
Threshold: covered with steel

Total height < 2,5 m:

Possible reverse montage:

Installation kit:

Storm braces:

*See optional products pages 26-27

Alva 4x4

Article No. S26200

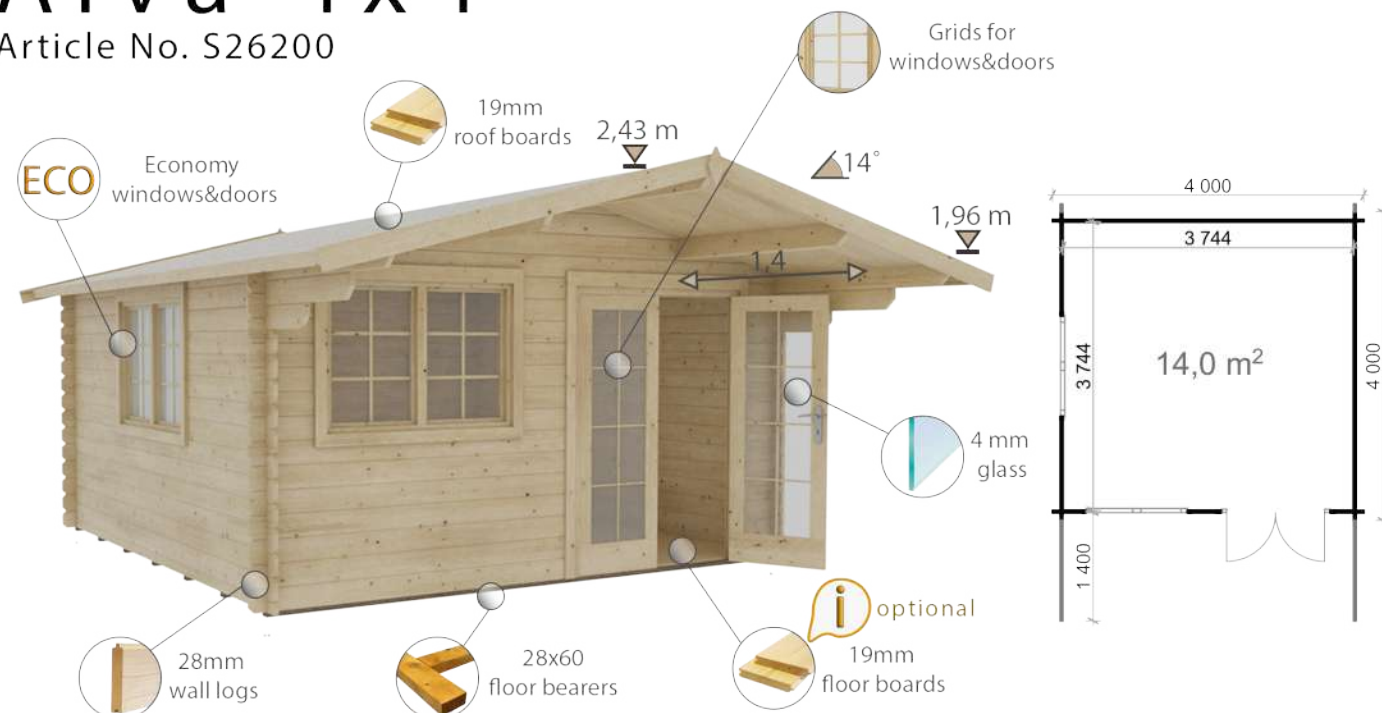

Project specification:

External measures: 4x4 m
Base footprint: 3,8x3,8 m
Internal house area: 14 m²
External wall area: 32 m²
Roof area: 24 m²

Windows and doors:

Door: 1 double 100% glass 1,85x1,4 m
Window: 2 double 0,92x1,3 m
Threshold: covered with steel

Total height < 2,5 m:

Possible reverse montage:

Installation kit:

Storm braces:

*See optional products pages 26-27

Atlanta 3,56x2,2

Article No. S26286

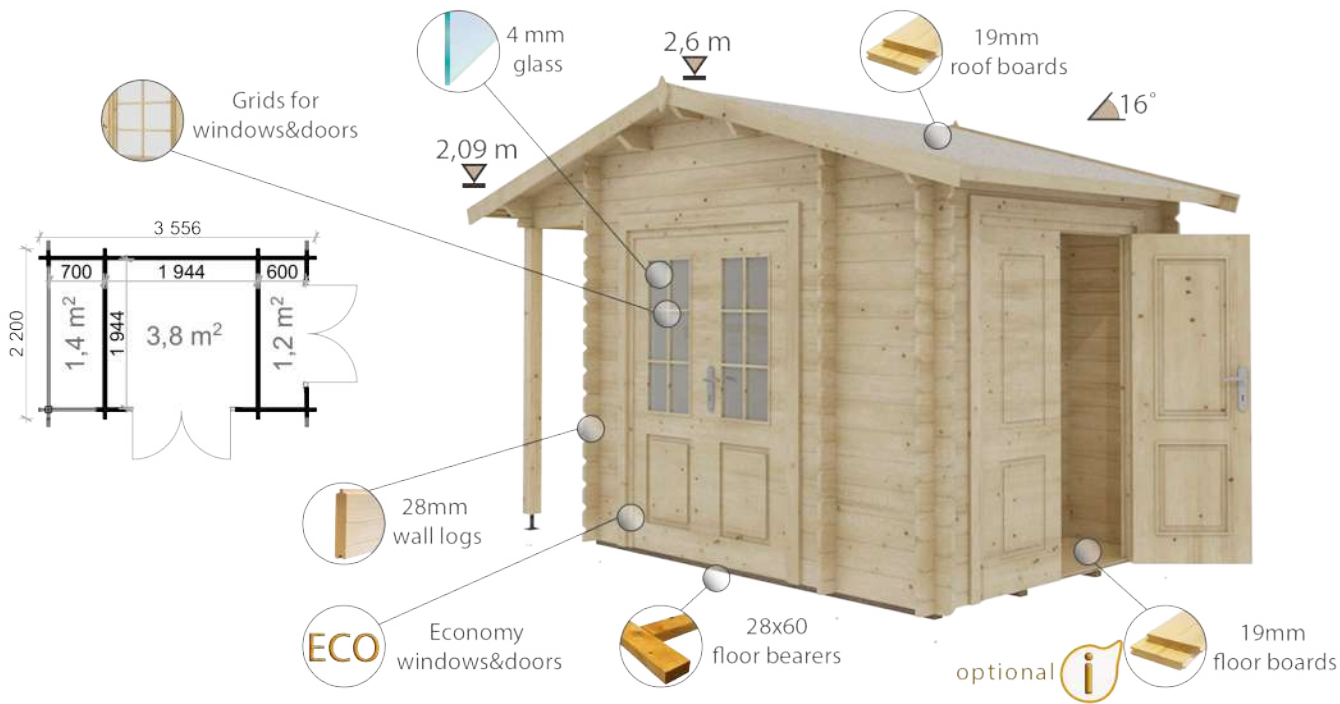

Project specification:

External measures: 3,56x2,2 m
 Base footprint: 3,36x2 m
 Internal house area: 5 m²
 External wall area: 21,2 m²
 Roof area: 9,6 m²

Windows and doors:

Door: 1 double 50% glass 1,85x1,4 m,
 1 double full wood 1,85x1,4
 Threshold: covered with steel

Installation kit:

Storm braces:

*See optional products pages 26-27

Bedford 2,2x2,2

Article No. S26201

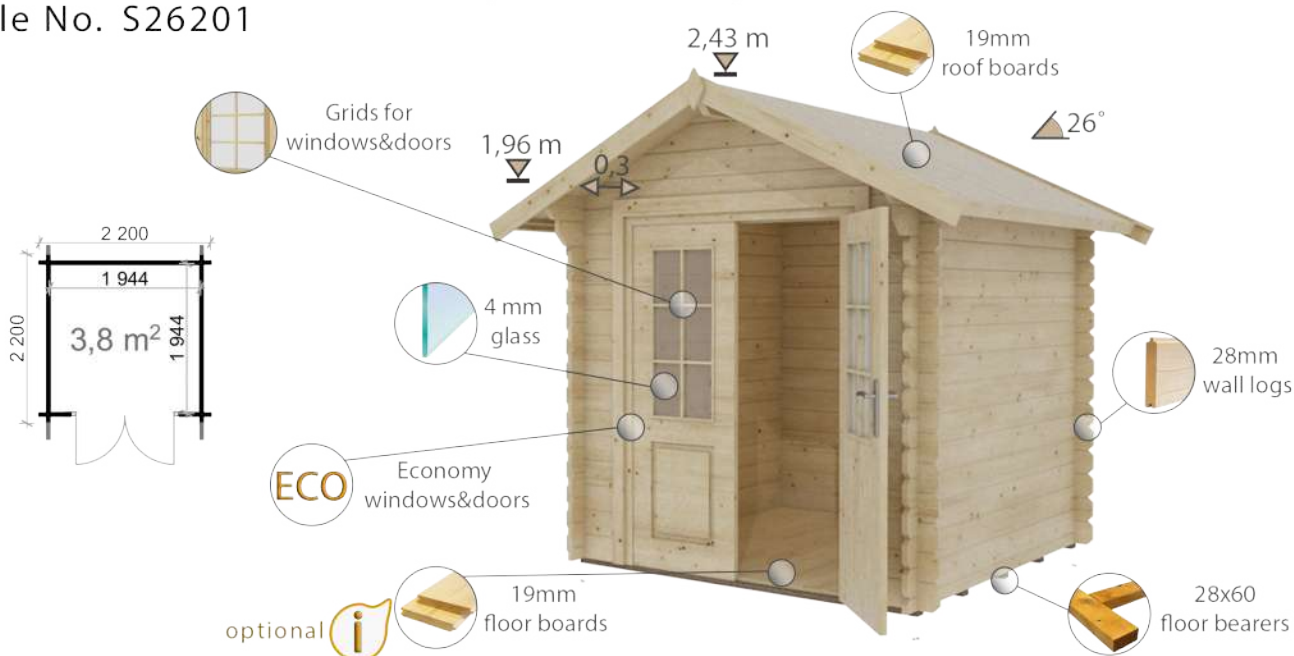

Project specification:

External measures: 2,2x2,2 m
 Base footprint: 2x2 m
 Internal house area: 3,8 m²
 External wall area: 16 m²
 Roof area: 7 m²

Windows and doors:

Door: 1 double 50% glass 1,85x1,4 m
 Threshold: covered with steel

Total height < 2,5 m:

Installation kit:

Storm braces:

*See optional products pages 26-27

Bedford 2,2x3

Article No. S26202

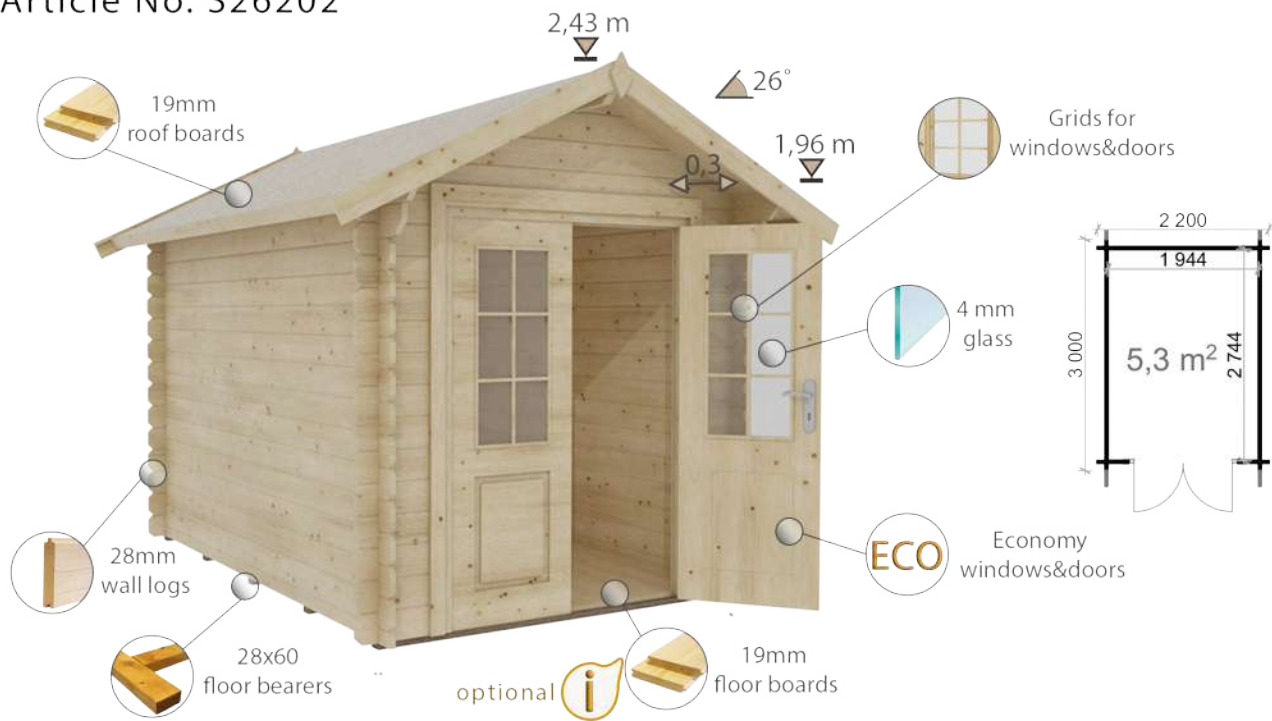

Project specification:

External measures: 2,2x3 m
Base footprint: 2x2,8 m
Internal house area: 5,3 m²
External wall area: 19 m²
Roof area: 9,2 m²

Windows and doors:

Door: 1 double 50% glass 1,85x1,4 m
Threshold: covered with steel

Total height < 2,5 m:

Possible reverse montage:

Installation kit:

Storm braces:

*See optional products pages 26-27

Elise 3x5,9

Article No. S26211

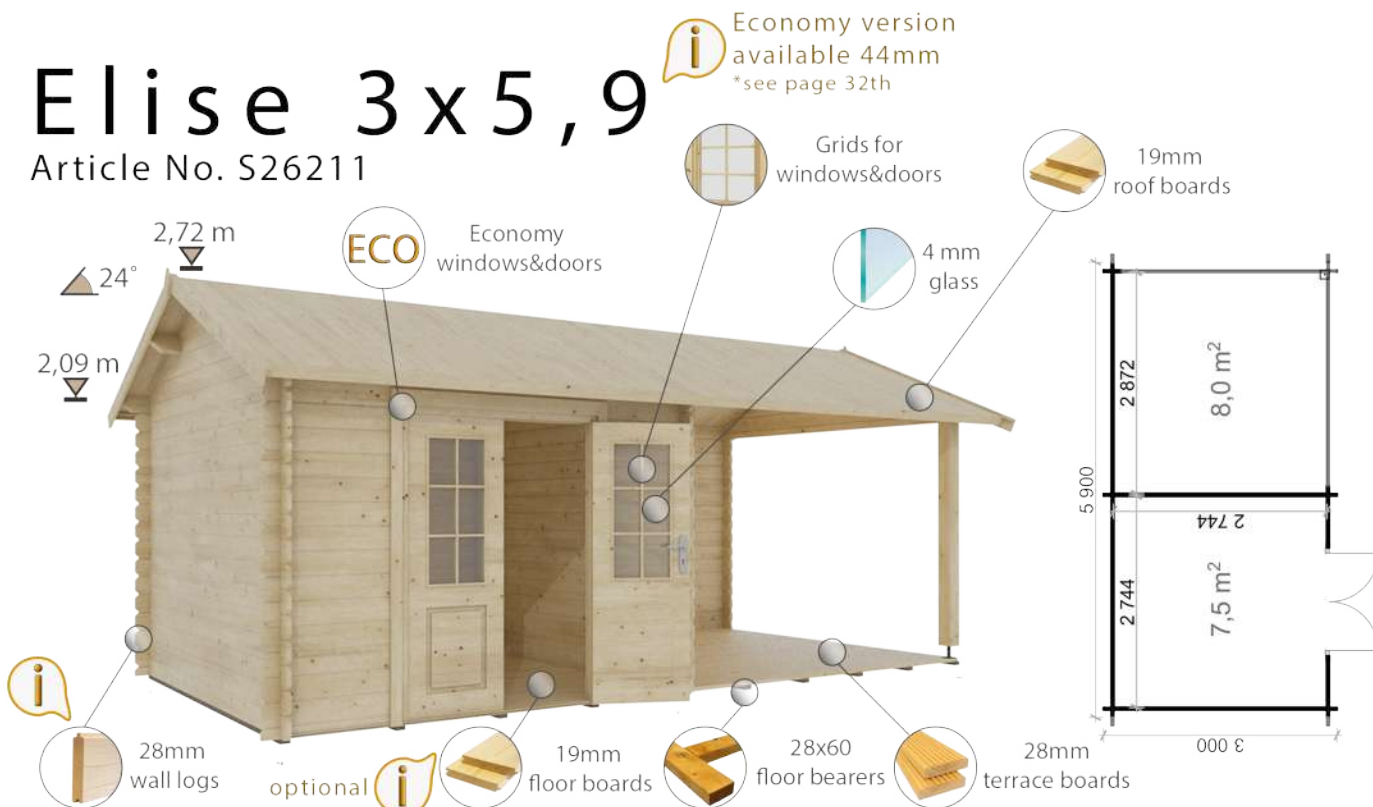

Project specification:

External measures: 3x5,9 m
Base footprint: 2,8x5,7 m
Internal house area: 7,5 m²
External wall area: 33,2 m²
Roof area: 22 m²

Windows and doors:

Door: 1 double 50% glass 1,85x1,4 m
Threshold: covered with steel

Installation kit:

Storm braces:

Terrace area: 8 m²

*See optional products pages 26-27

Emma 3x3

Article No. S26212

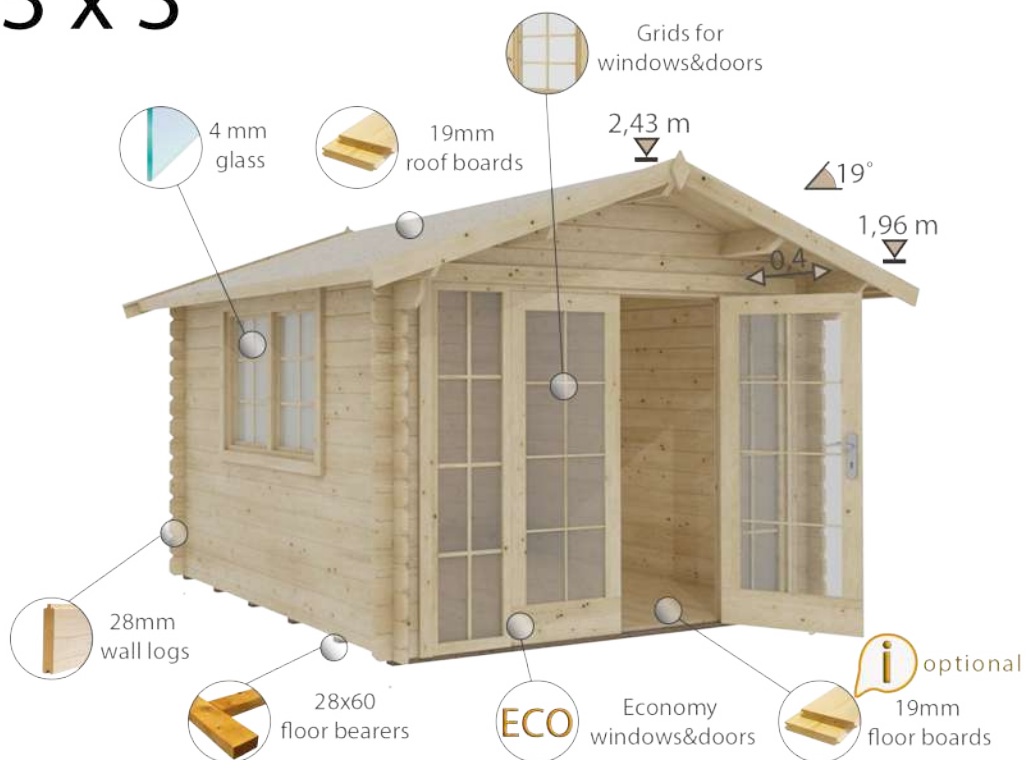
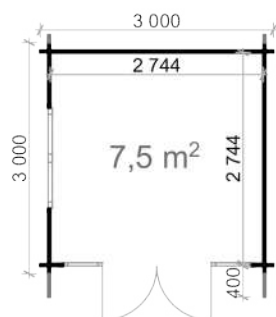

Project specification:

External measures: 3x3 m
Base footprint: 2,8x2,8 m
Internal house area: 7,5 m²
External wall area: 19,5 m²
Roof area: 12 m²

Windows and doors:

Door: 1 quadruple 100% glass 1,85x2,4 m (door 1,85x1,4 m and 2 units of windows 1,85x0,5 m)
Window: 1 double 0,92x1,3 m
Threshold: covered with steel

Total height < 2,5 m:

Possible reverse montage:

Installation kit:

Storm braces:

*See optional products pages 26-27

Emma 4x3

Article No. S26213

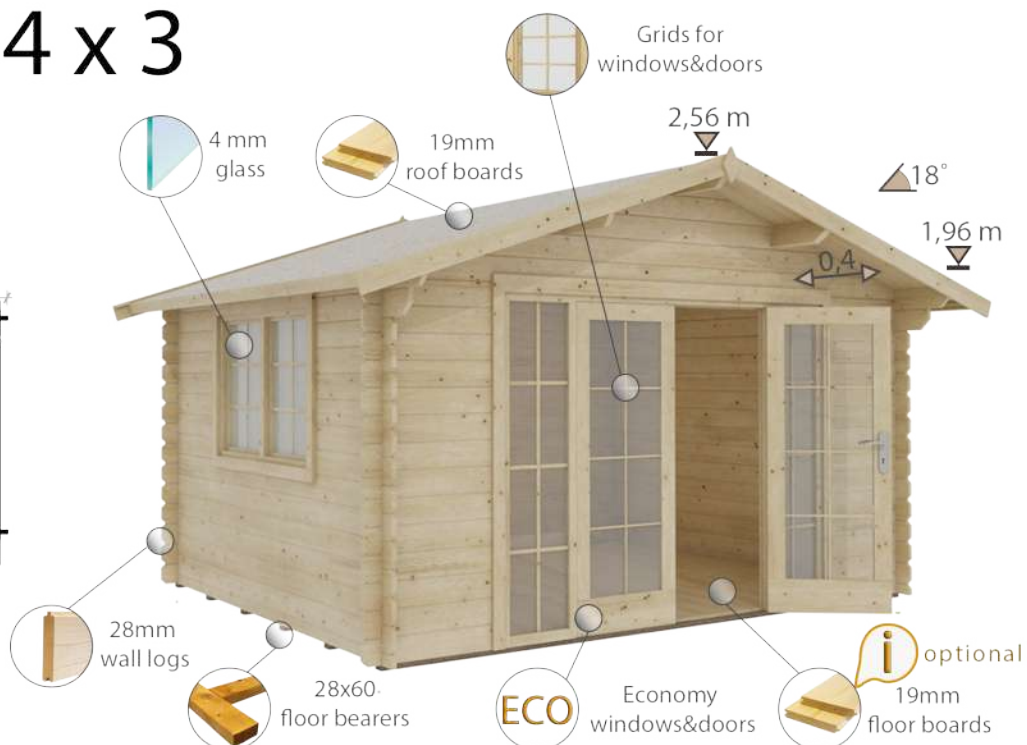
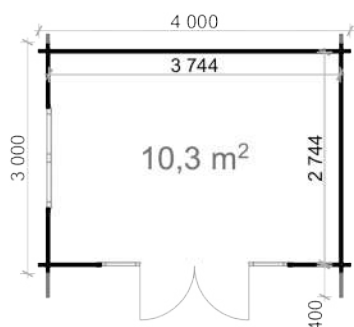

Project specification:

External measures: 4x3 m
Base footprint: 3,8x2,8 m
Internal house area: 10,3 m²
External wall area: 24,6 m²
Roof area: 15,4 m²

Windows and doors:

Door: 1 quadruple 100% glass 1,85x2,4 m (door 1,85x1,4 m and 2 units of windows 1,85x0,5 m)
Window: 1 double 0,92x1,3 m
Threshold: covered with steel

Possible reverse montage:

Installation kit:

Storm braces:

*See optional products pages 26-27

Erna 2,5x3,4

Article No. S26215

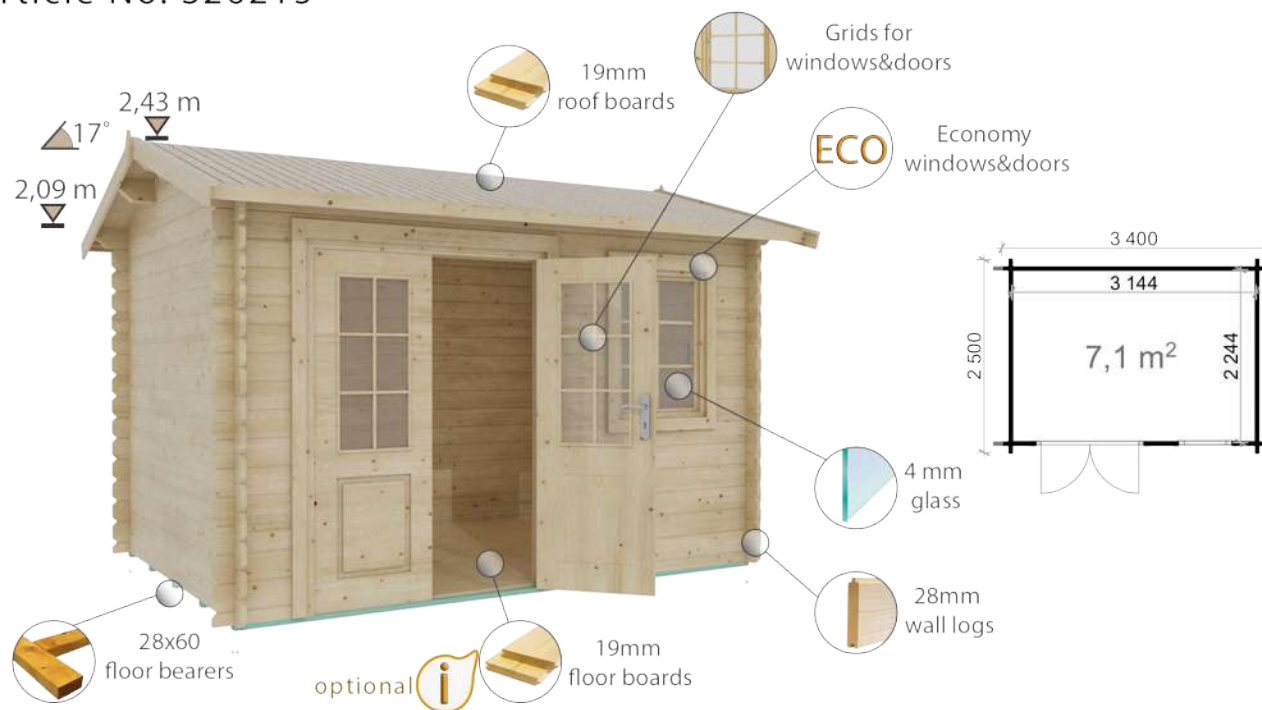

Project specification:

External measures: 2,5x3,4 m
Base footprint: 2,3x3,2 m
Internal house area: 7,1 m²
External wall area: 22,6 m²
Roof area: 10,5 m²

Windows and doors:

Door: 1 double 50% glass 1,85x1,4 m
Window: 1 single 0,92x0,7 m
Threshold: covered with steel

Total height < 2,5 m:

Possible reverse montage:

Installation kit:

Storm braces:

*See optional products pages 26-27

Genova 3,8x3

Article No. S26224

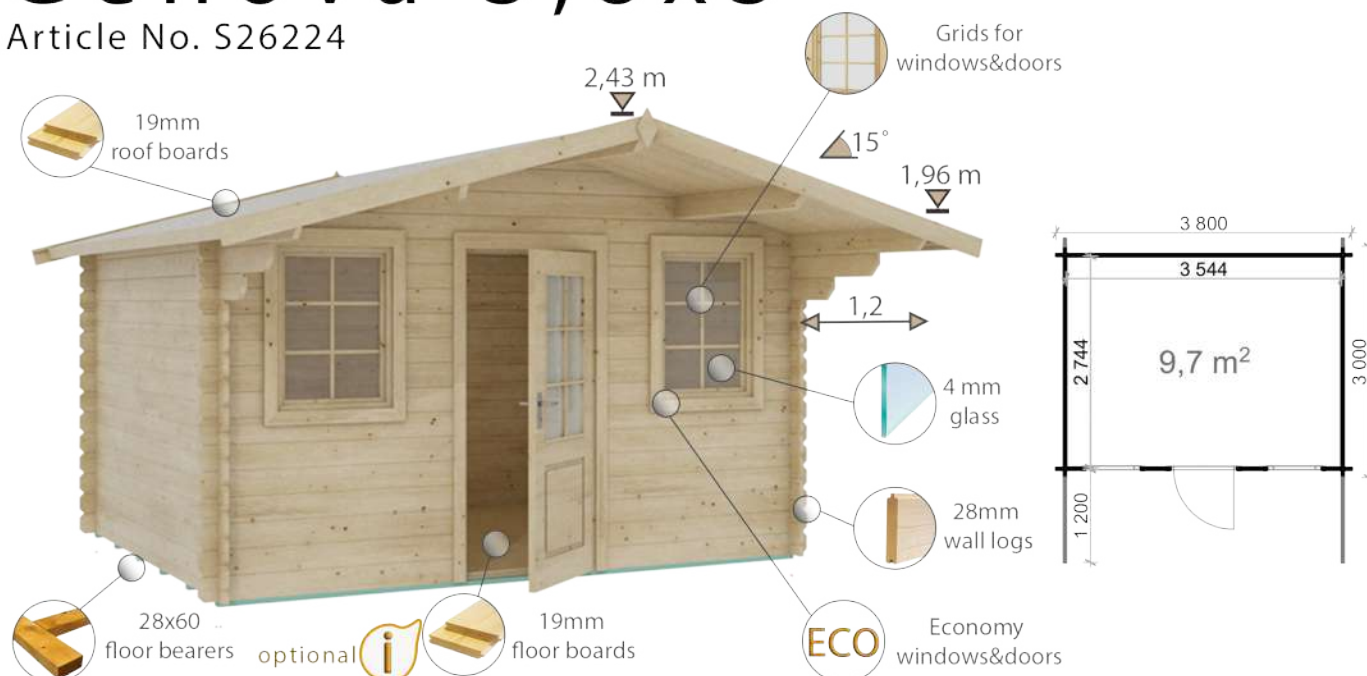

Project specification:

External measures: 3,8x3 m
Base footprint: 3,6x2,8 m
Internal house area: 9,7 m²
External wall area: 26,4 m²
Roof area: 17,8 m²

Windows and doors:

Door: 1 single 50% glass 1,85x0,85 m
Window: 2 single 0,92x0,7 m
Threshold: covered with steel

Total height < 2,5 m:

Possible reverse montage:

Installation kit:

Storm braces:

*See optional products pages 26-27

Imperial 3x3

Article No. S26232



Project specification:

External measures: 3x3 m
 Base footprint: 2,8x2,8 m
 Internal house area: 7,5 m²
 External wall area: 22,6 m²
 Roof area: 14,7 m²

Windows and doors:

Door: 1 double 100% glass 1,85x1,4 m
 Window: 1 single 0,92x0,7 m
 Threshold: covered with steel

Total height < 2,5 m:

Possible reverse montage:

Installation kit:

Storm braces:

*See optional products pages 26-27

Kiosk 3x3

Article No. S26636

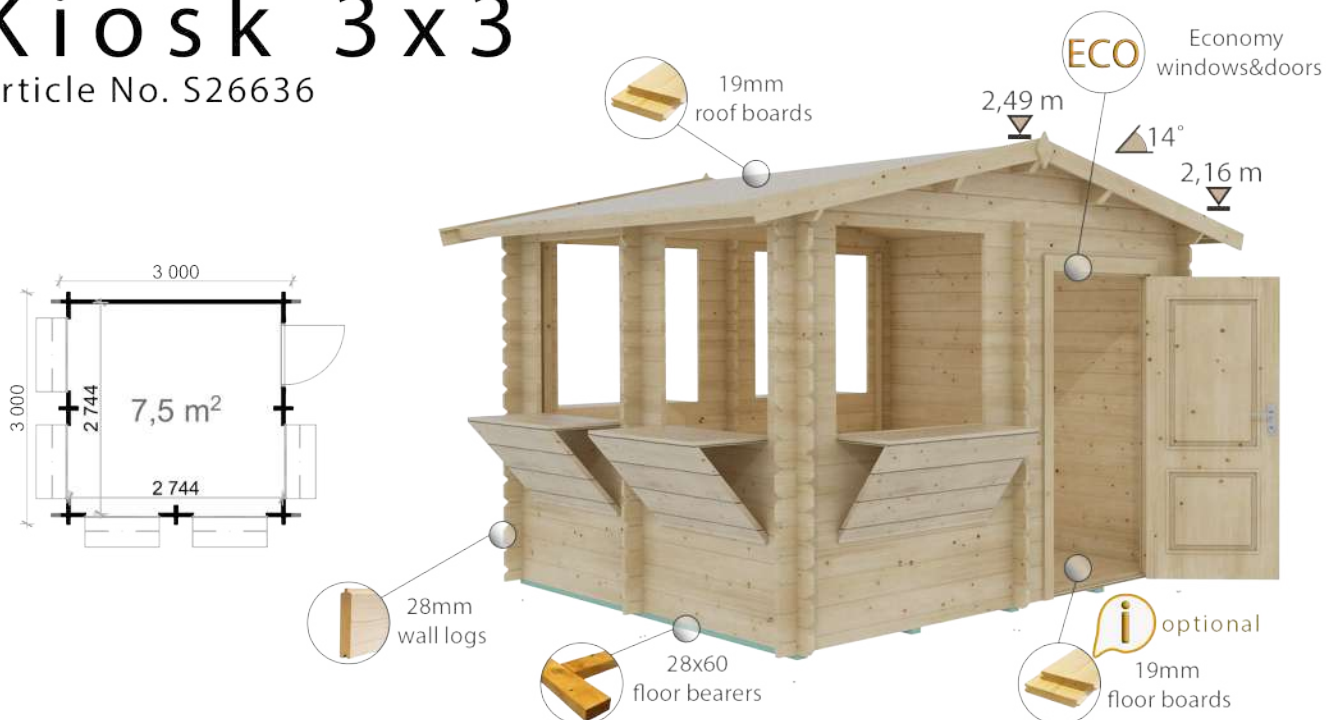

Project specification:

External measures: 3x3 m
 Base footprint: 2,8x2,8 m
 Internal house area: 7,5 m²
 External wall area: 21 m²
 Roof area: 10,9 m²

Windows and doors:

Door: 1 single full wood 1,85x0,85 m
 Shutters: 5 kiosk type 1x0,96 m
 Threshold: covered with steel

Total height < 2,5 m:

Possible reverse montage:

Installation kit:

Storm braces:

*See optional products pages 26-27

Kiosk 4x4

Article No. S26638

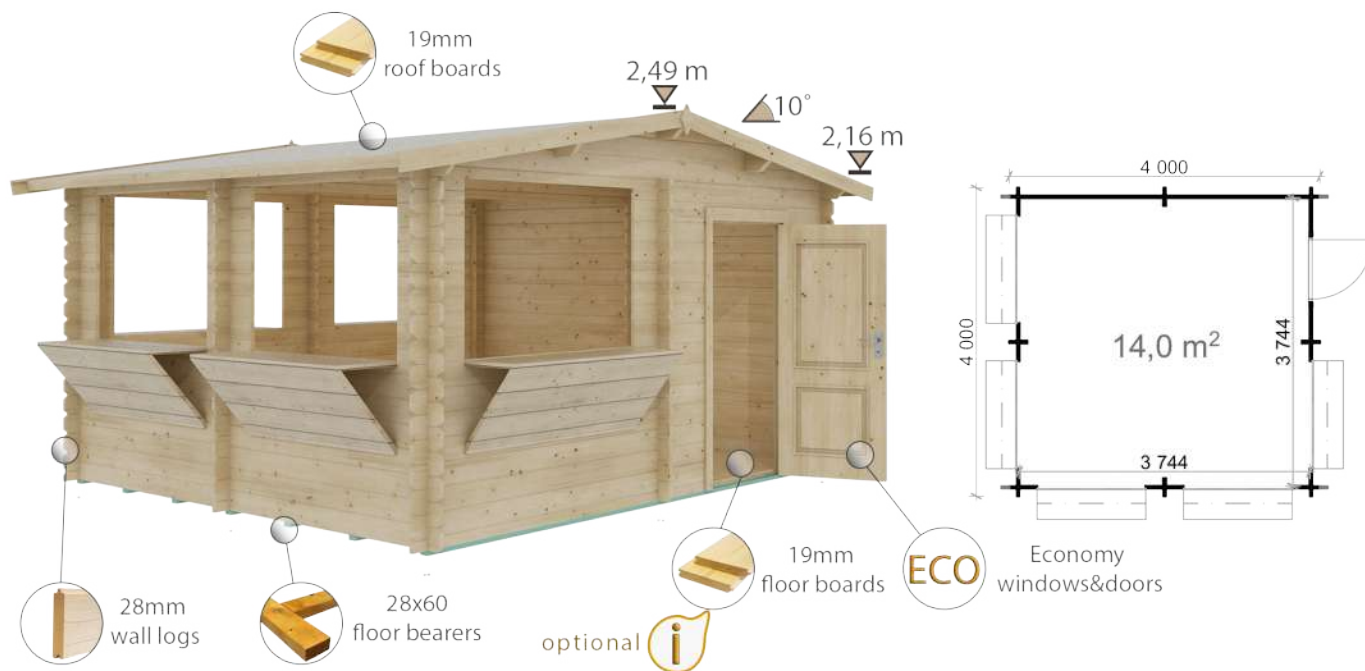

Project specification:

External measures: 4x4 m
Base footprint: 3,8x3,8 m
Internal house area: 14 m²
External wall area: 29 m²
Roof area: 18,4 m²

Windows and doors:

Door: 1 single full wood 1,85x0,85 m
Shutters: 5 kiosk type 1x1,4 m
Threshold: covered with steel

Total height < 2,5 m:

Possible reverse montage:

Installation kit:

Storm braces:

*See optional products pages 26-27

Mantova 2,5x2

Article No. S26244

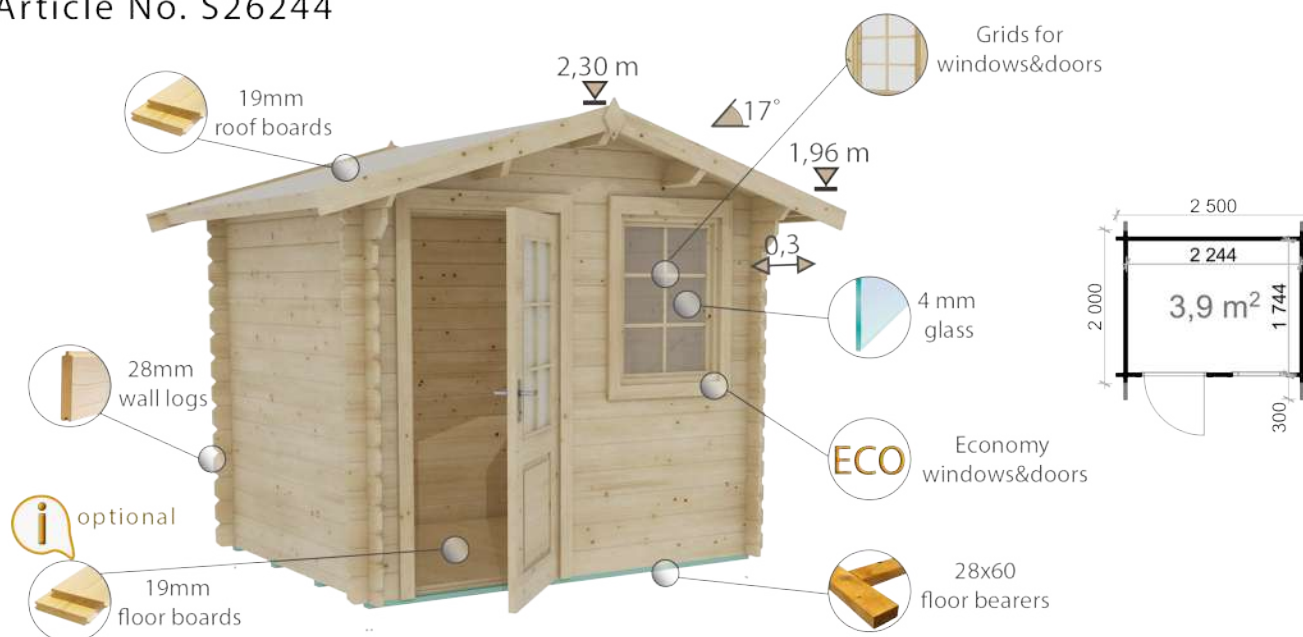

Project specification:

External measures: 2,5x2 m
Base footprint: 2,3x1,8 m
Internal house area: 3,9 m²
External wall area: 16,5 m²
Roof area: 6,7 m²

Windows and doors:

Door: 1 single 50% glass 1,85x0,85 m
Window: 1 single 0,92x0,7
Threshold: covered with steel

Total height < 2,5 m:

Possible reverse montage:

Installation kit:

Storm braces:

*See optional products pages 26-27

Megy 2,6x4,1

Article No. S26293

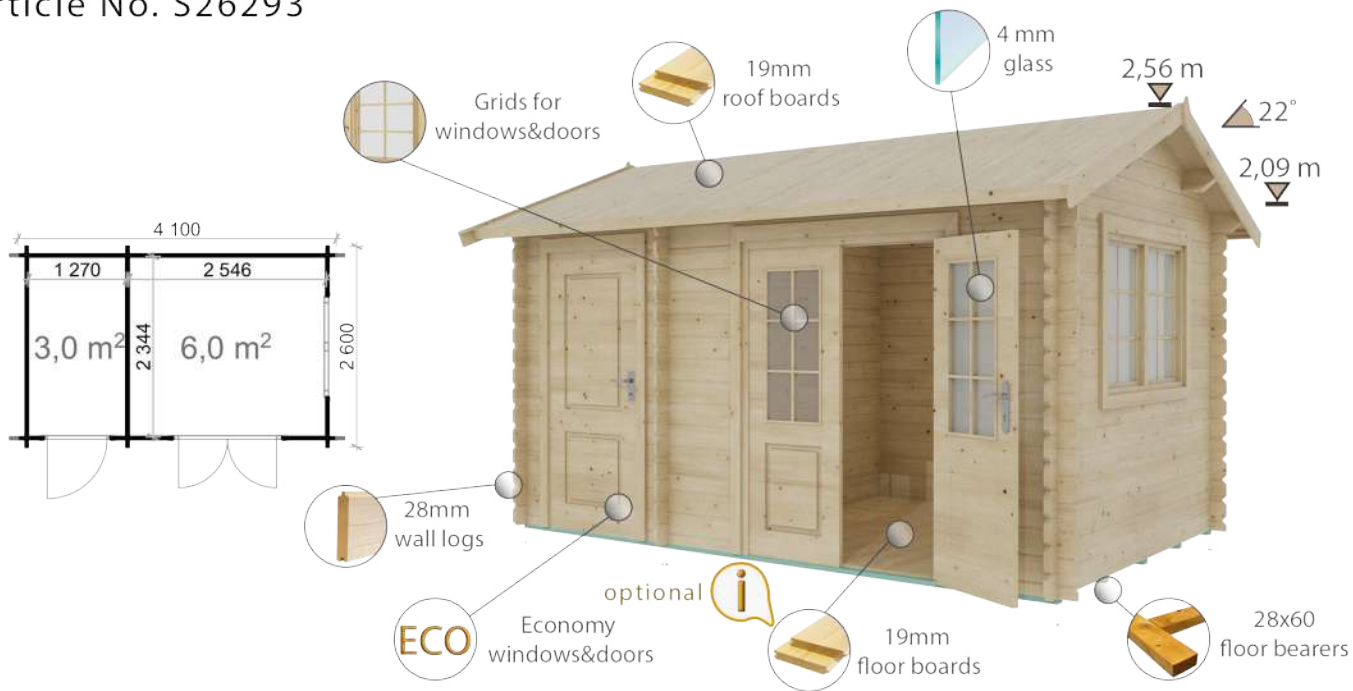

Project specification:

External measures: 2,6x4,1 m
Base footprint: 2,4x3,9 m
Internal house area: 9 m²
External wall area: 24,2 m²
Roof area: 13,4 m²

Windows and doors:

Door: 1 double 50% glass 1,85x1,4 m and 1 single full wood 1,85x0,85 m
Window: 1 double 0,92x1,3 m
Threshold: covered with steel

Possible reverse montage:

Installation kit:

Storm braces:

*See optional products pages 26-27

Modena 3x2,5

Article No. S26247



Project specification:

External measures: 3x2,5 m
Base footprint: 2,8x2,3 m
Internal house area: 6,2 m²
External wall area: 21 m²
Roof area: 12,9 m²

Windows and doors:

Door: 1 single 50% glass 1,85x0,85 m
Window: 2 single 0,92x0,7 m
Threshold: covered with steel

Total height < 2,5 m:

Possible reverse montage:

Installation kit:

Storm braces:

*See optional products pages 26-27

Osaka 3,2x3,2

Article No. S26294



Project specification:

External measures: 3,2x3,2 m
Base footprint: 3x3 m
Internal house area: 8,7 m²
External wall area: 28 m²
Roof area: 14,7 m²

Windows and doors:

Door: 1 double full wood 1,85x1,4 m
Window: 1 single 0,39x1,5 m
Threshold: covered with steel

Possible reverse montage:

Installation kit:

Storm braces:

*See optional products pages 26-27



Bogota 2,5x4

Article No. S26640

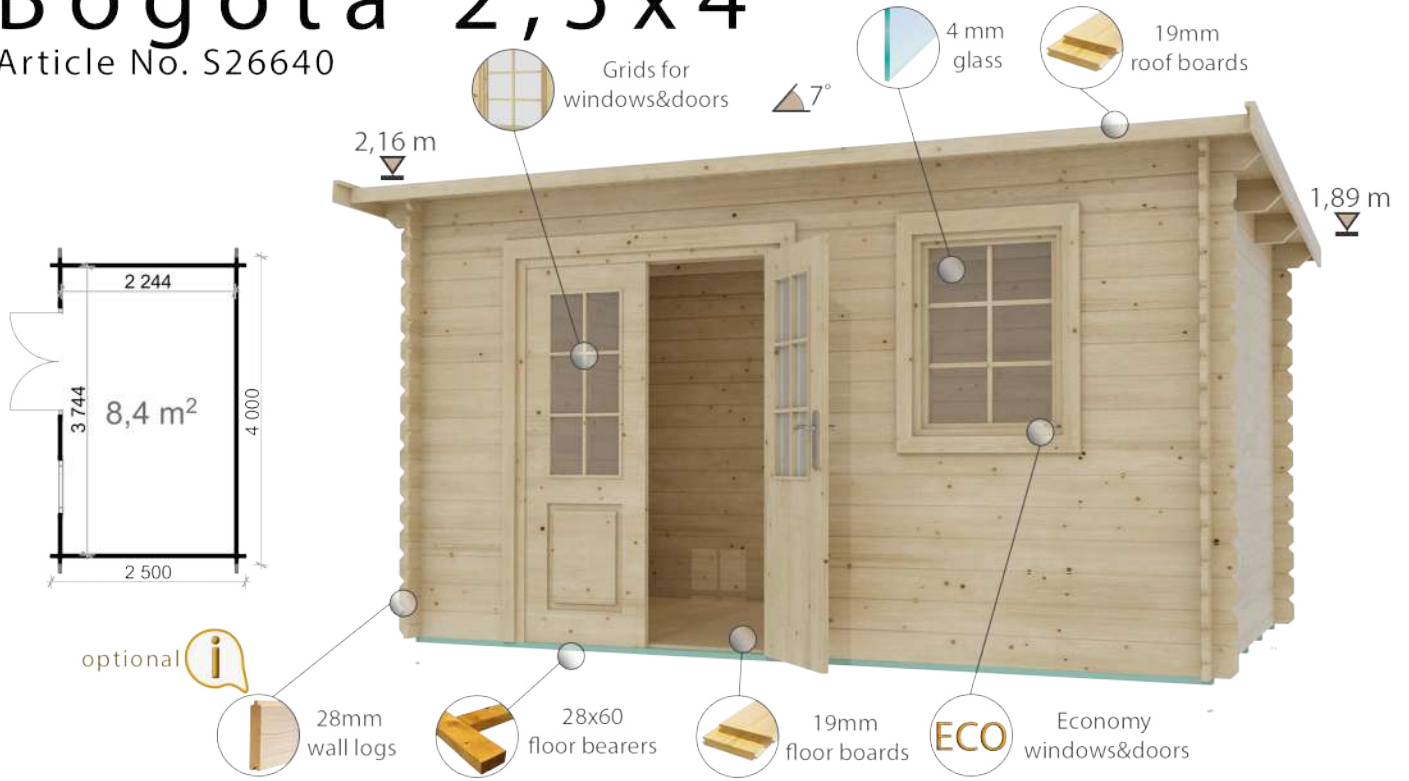

Project specification:

External measures: 2,5x4 m
 Base footprint: 2,3x3,8 m
 Internal house area: 8,4 m²
 External wall area: 24 m²
 Roof area: 11,8 m²

Windows and doors:

Door: 1 double 50% glass 1,85x1,4 m
 Window: 1 single 0,92x0,7 m
 Threshold: covered with steel

Total height < 2,5 m:

Possible reverse montage:

Installation kit:

Storm braces:

*See optional products pages 26-27



Edith series



Windows and doors:

Door: 1 double 50% glass 1,85x1,4 m
Threshold: covered with steel

- Total height < 2,5 m:
- Possible reverse montage:
- Installation kit:
- Storm braces:

*See optional products pages 26-27

Edith 2,2x2,2

Article No. S26333

Project specification:

External measures: 2,2x2,2 m
Base footprint: 2x2 m
Internal house area: 3,8 m²
External wall area: 17 m²
Roof area: 6,6 m²
Roof angle: 8°

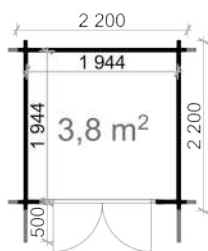

Edith 3x2,5

Article No. S26334

Project specification:

External measures: 3x2,5 m
Base footprint: 2,8x2,3 m
Internal house area: 6,2 m²
External wall area: 21 m²
Roof area: 9,7 m²
Roof angle: 7°

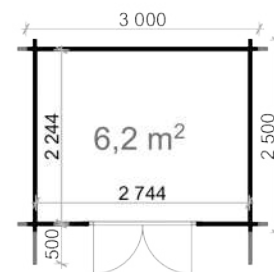

Edith 2x3

Article No. S26335

Project specification:

External measures: 2x3 m
Base footprint: 1,8x2,8 m
Internal house area: 4,8 m²
External wall area: 19 m²
Roof area: 7,8 m²
Roof angle: 6°

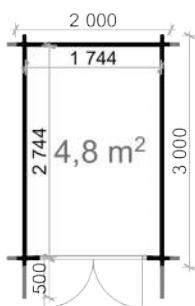

Edith 3x3

Article No. S26209

Project specification:

External measures: 3x3 m
Base footprint: 2,8x2,8 m
Internal house area: 7,5 m²
External wall area: 23 m²
Roof area: 11,3 m²
Roof angle: 6°



Edith 3x2

Article No. S26208

Project specification:

External measures: 3x2 m
Base footprint: 2,8x1,8 m
Internal house area: 4,8 m²
External wall area: 19 m²
Roof area: 8,1 m²
Roof angle: 9°

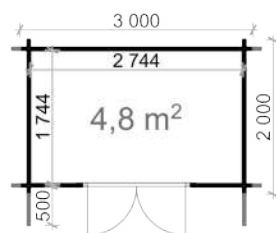

Lima 4,5x3

Article No. S26269

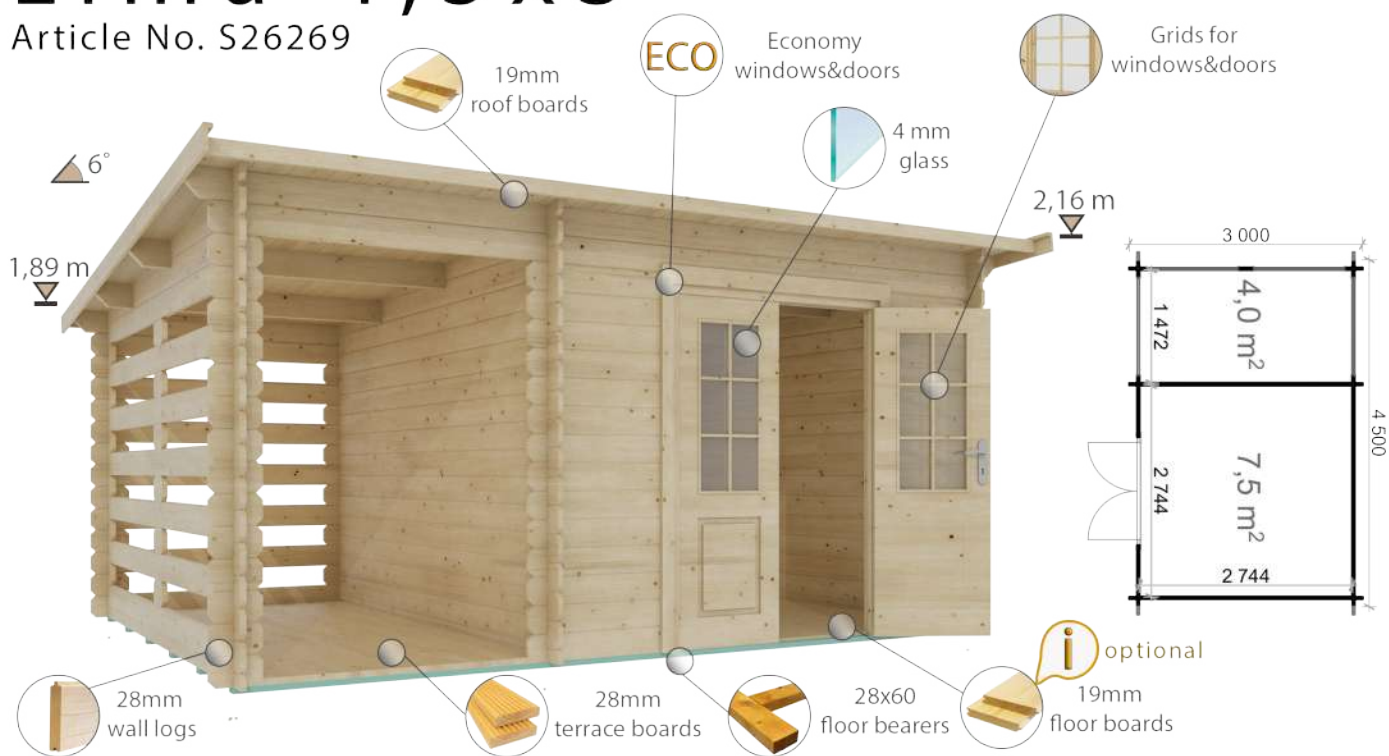

Project specification:

External measures: 4,5x3 m
 Base footprint: 4,3x2,8 m
 Internal house area: 7,5 m²
 External wall area: 29 m²
 Roof area: 15,6 m²

Windows and doors:

Door: 1 double 50% glass 1,85x1,4 m
 Threshold: covered with steel

Total height < 2,5 m:

Installation kit:

Storm braces:

Terrace area: 4 m²

*See optional products pages 18-20

Toronto 3x3

Article No. S26295



Project specification:

External measures: 3x3 m
 Base footprint: 2,8x2,8 m
 Internal house area: 7,5 m²
 External wall area: 25 m²
 Roof area: 10,8 m²

Windows and doors:

Door: 1 double full wood 1,85x1,4 m
 Window: 1 single 0,39x1,5 m
 Threshold: covered with steel

Possible reverse montage:

Installation kit:

Storm braces:

*See optional products pages 18-20

Dalás 2,6x2,6

Article No. S26288

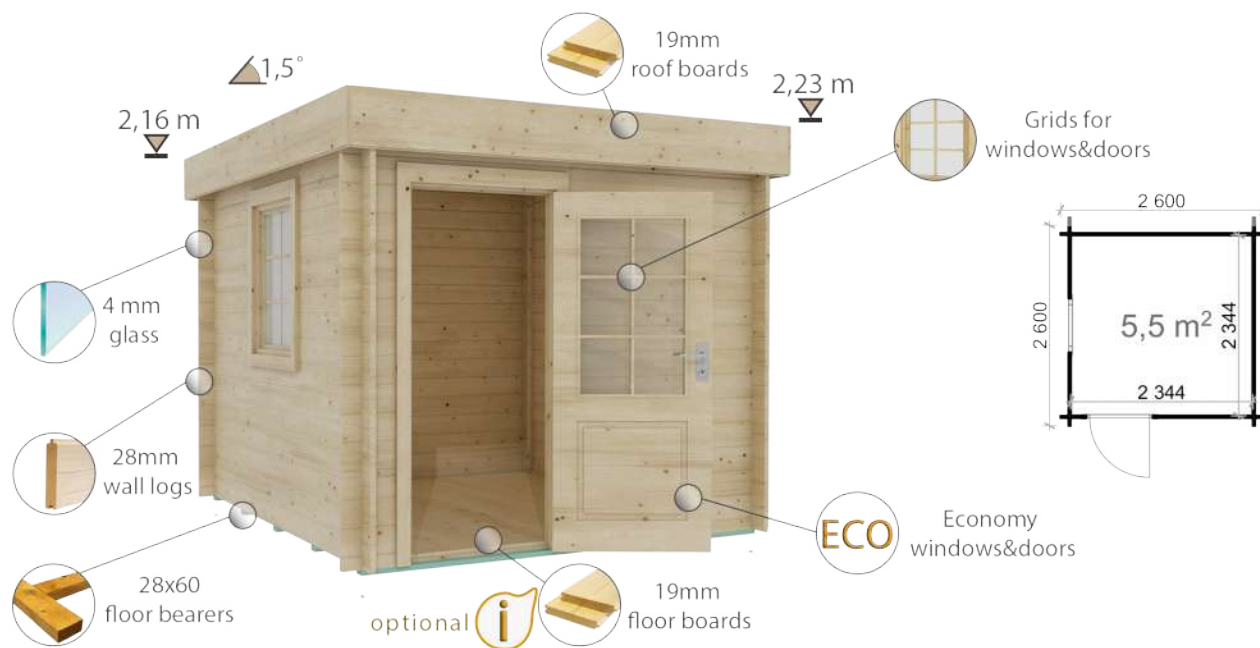

Project specification:

External measures: 2,6x2,6 m
Base footprint: 2,4x2,4 m
Internal house area: 5,5 m²
External wall area: 21 m²
Roof area: 7 m²

Windows and doors:

Door: 1 single 50% glass 1,85x0,85 m
Window: 1 single 0,92x0,7
Threshold: covered with steel

Total height < 2,5 m:

Possible reverse montage:

Installation kit:

Storm braces:

*See optional products pages 26-27

Eric 3,3x7,36

Article No. S26214

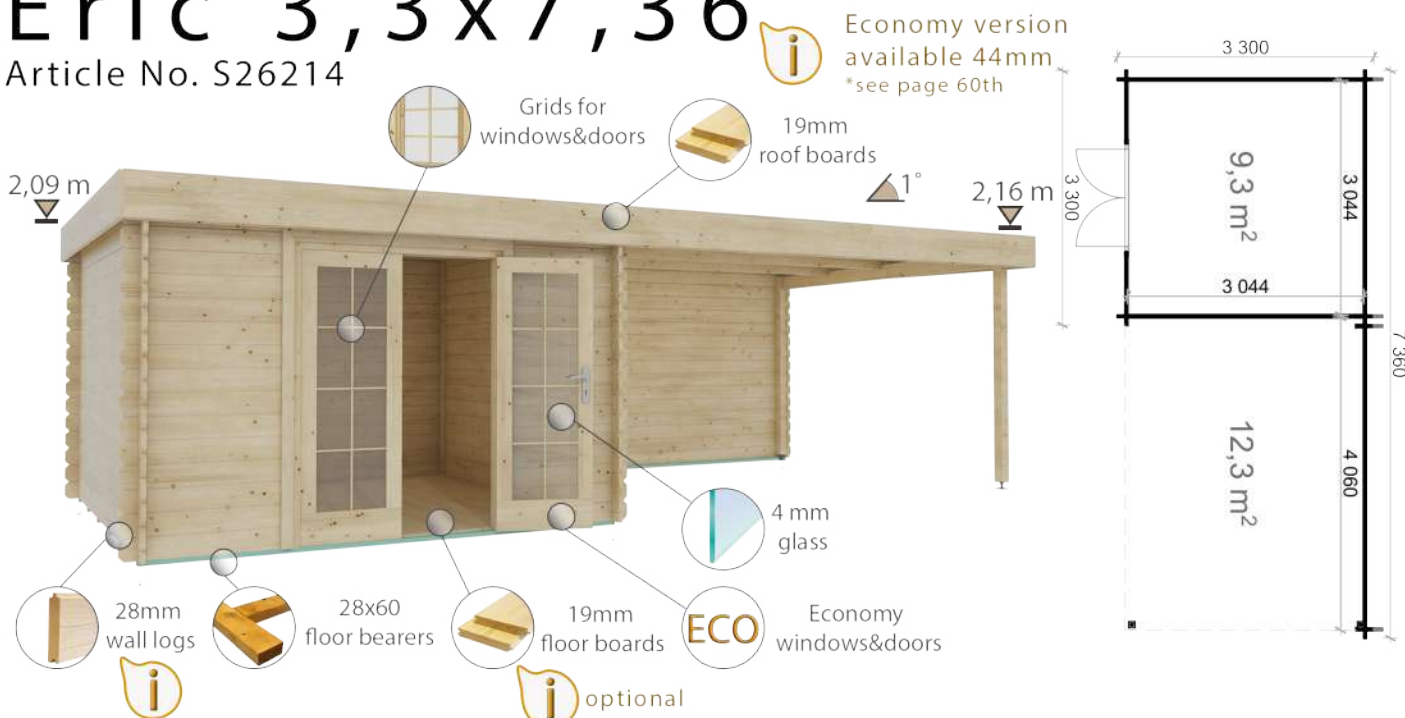

Project specification:

External measures: 3,3x7,36 m
Base footprint: 3,1x7,16 m
Internal house area: 9,3m²
External wall area: 35 m²
Roof area: 25 m²

Windows and doors:

Door: 1 double 100% glass 1,85x1,4 m
Threshold: covered with steel

Total height < 2,5 m:

Installation kit:

Storm braces:

*See optional products pages 26-27

Lulu-1 2,4x1,2

Article No. S26289



Project specification:

External measures: 2,4x1,2 m
 Base footprint: 2,2x1 m
 Internal house area: 2 m²
 External wall area: 15 m²
 Roof area: 2,9 m²

Windows and doors:

Door: 1 single full wood 1,85x0,85 m
 Window: 1 single 0,39x0,7 m
 Threshold: covered with steel

Total height < 2,5 m:

Possible reverse montage:

Installation kit:

Storm braces:

*See optional products pages 26-27

Lulu-2 2,4x2,4

Article No. S26290



Project specification:

External measures: 2,4x2,4 m
 Base footprint: 2,2x2,2 m
 Internal house area: 4,6 m²
 External wall area: 22 m²
 Roof area: 6 m²

Windows and doors:

Door: 1 single full wood 1,85x0,85 m
 Window: 2 single 0,39x0,7 m
 Threshold: covered with steel

Total height < 2,5 m:

Possible reverse montage:

Installation kit:

Storm braces:

*See optional products pages 26-27

Lulu-3 3,4x2,4

Article No. S26291

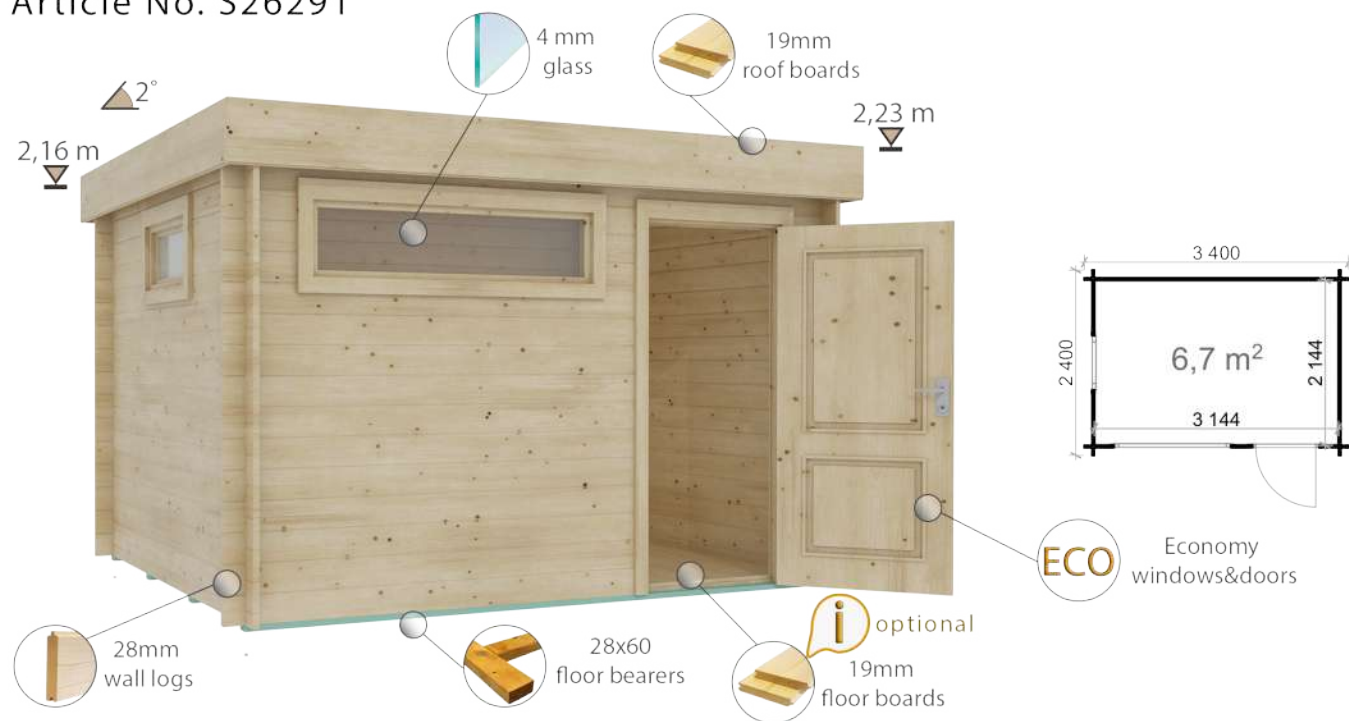

Project specification:

External measures: 3,4x2,4 m
Base footprint: 3,2x2,2 m
Internal house area: 6,7 m²
External wall area: 23,4 m²
Roof area: 8,2 m²

Windows and doors:

Door: 1 single full wood 1,85x0,85 m
Window: 1 single 0,39x1,5 m and
1 single 0,39x0,7 m
Threshold: covered with steel

Total height < 2,5 m:

Possible reverse montage:

Installation kit:

Storm braces:

*See optional products pages 26-27

Madrid 2,14x2,15

Article No. S26292



Project specification:

External measures: 2,14x2,15 m
Base footprint: 1,94x1,95 m
Internal house area: 3,6 m²
External wall area: 18 m²
Roof area: 5,3 m²

Windows and doors:

Door: 1 single 50% glass 1,85x0,85 m
Window: 1 single 0,39x0,7 m
Threshold: covered with steel

Total height < 2,5 m:

Possible reverse montage:

Installation kit:

Storm braces:

*See optional products pages 26-27

Amarillo 3x5,96

Article No. S28114

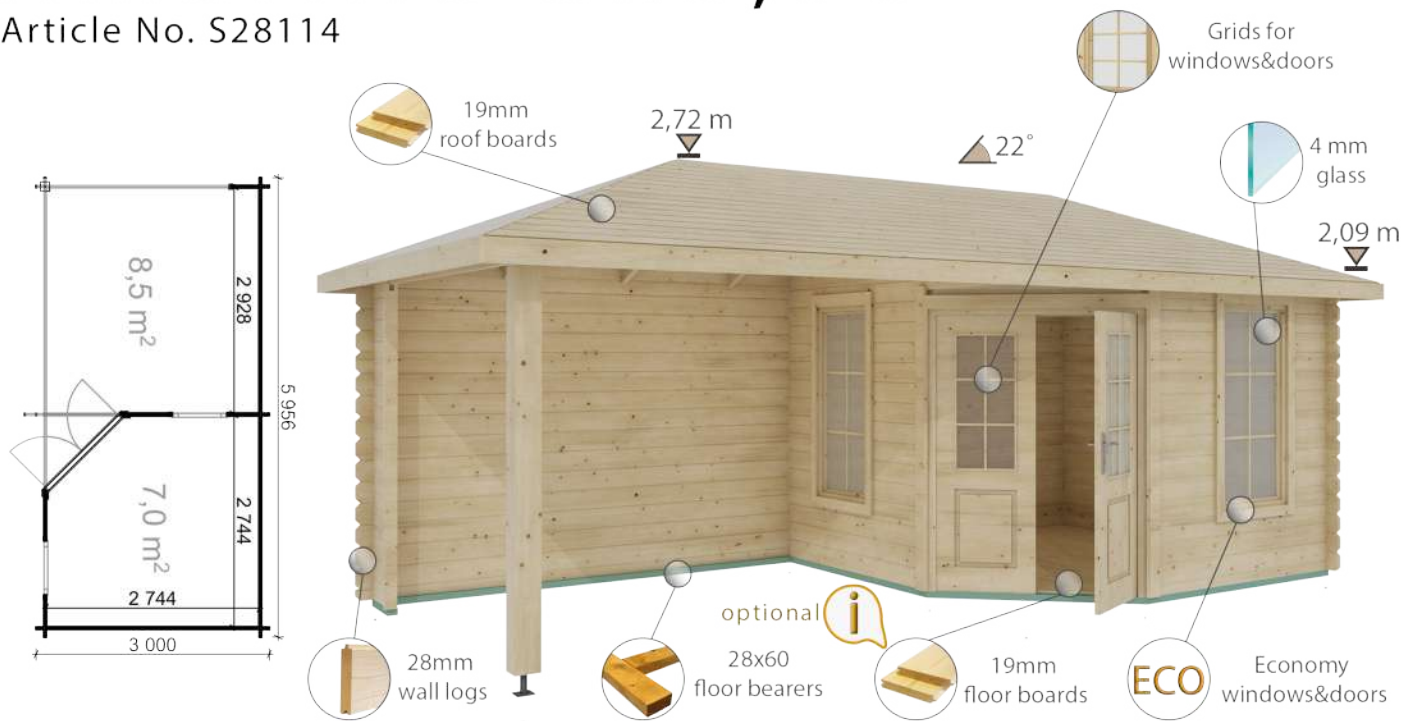

Project specification:

External measures: 3x5,96 m
Base footprint: 2,8x5,76 m
Internal house area: 7 m²
External wall area: 28 m²
Roof area: 22,3 m²

Windows and doors:

Door: 1 double 50% glass 1,85x1,4 m
Window: 2 single 1,43x0,7 m
Threshold: covered with steel

Installation kit:

Storm braces:

*See optional products pages 26-27

Colombo 2,6x2,6

Article No. S26239

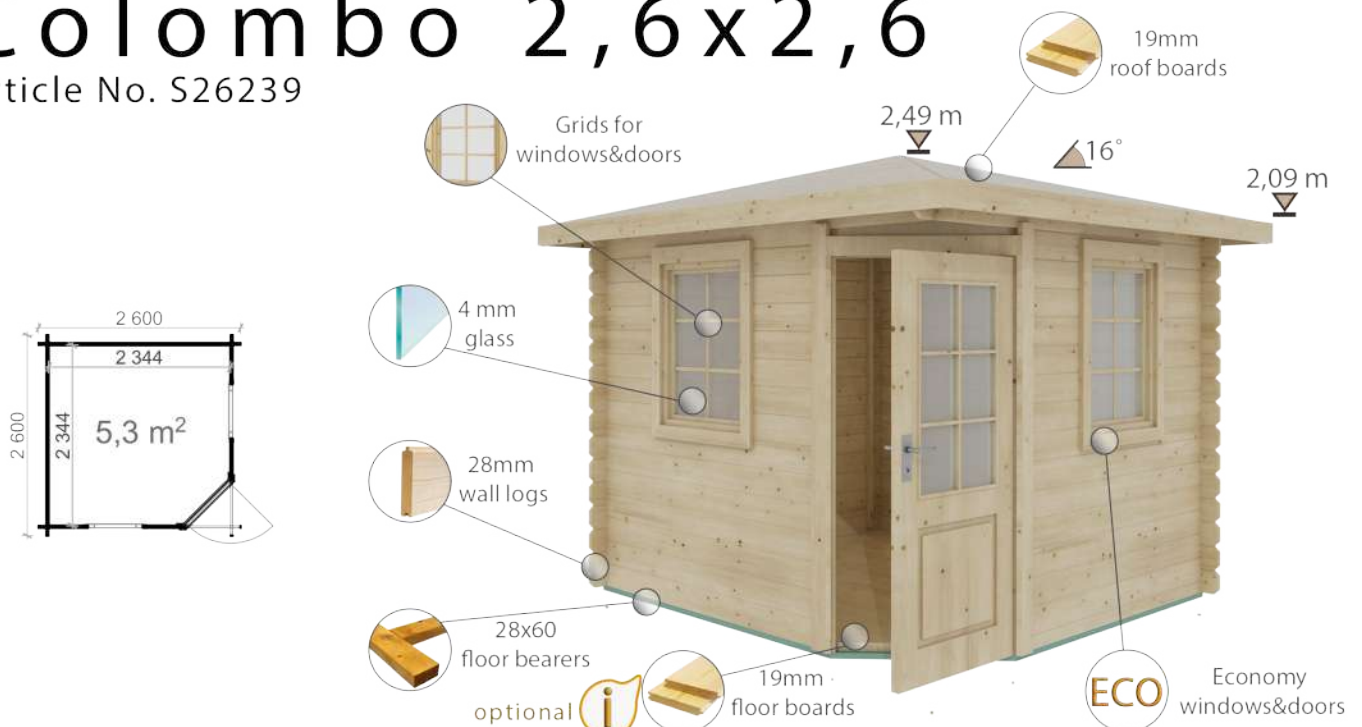

Project specification:

External measures: 2,6x2,6 m
Base footprint: 2,4x2,4 m
Internal house area: 5,3 m²
External wall area: 18 m²
Roof area: 8,7 m²

Windows and doors:

Door: 1 single 50% glass 1,85x0,85 m
Window: 2 single 0,92x0,7 m
Threshold: covered with steel

Total height < 2,5 m:

Installation kit:

Storm braces:

*See optional products pages 26-27

Luknė 3x3

Article No. S16294

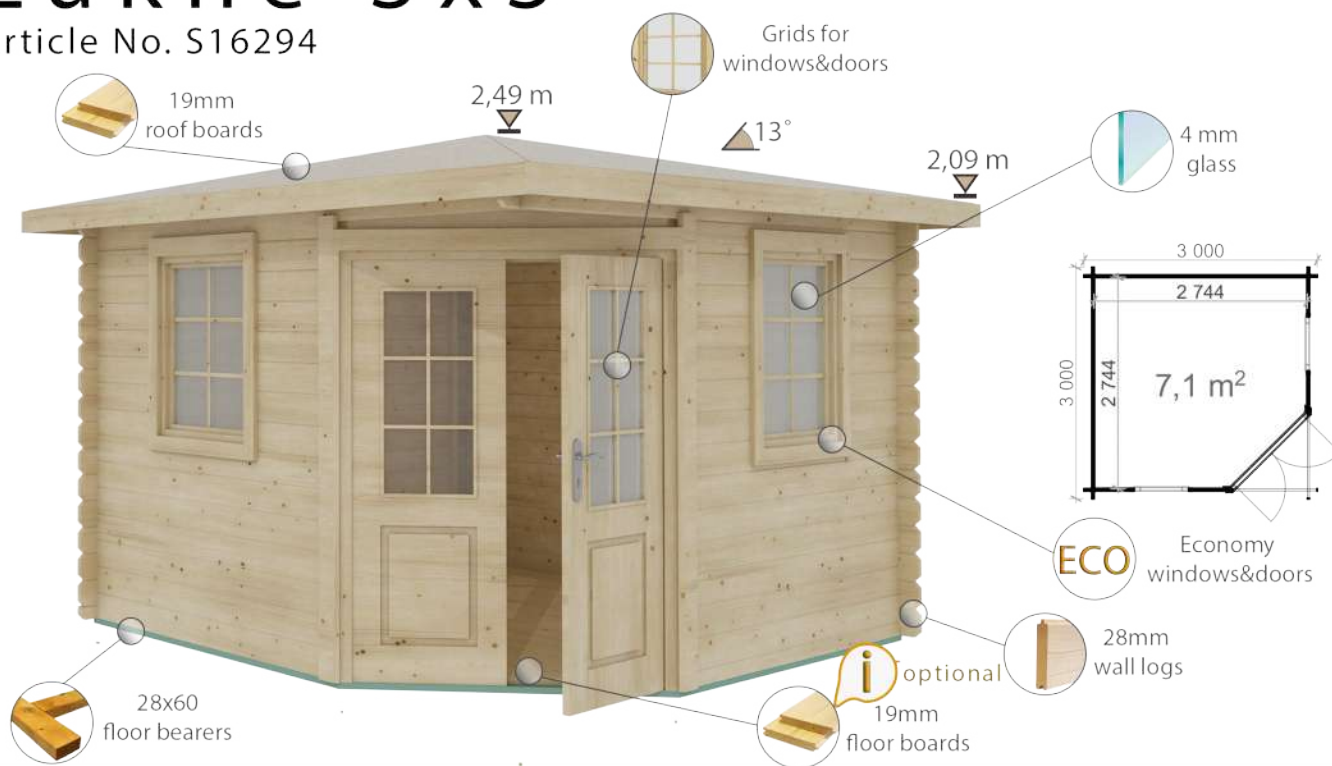

Project specification:

External measures: 3x3 m
Base footprint: 2,8x2,8 m
Internal house area: 7,1 m²
External wall area: 20 m²
Roof area: 10,8 m²

Windows and doors:

Door: 1 double 50% glass 1,85x1,4 m
Window: 2 single 0,92x0,7 m
Threshold: covered with steel

Total height < 2,5 m:

Installation kit:

Storm braces:

*See optional products pages 26-27

Rita 3x4,4

Article No. S26257

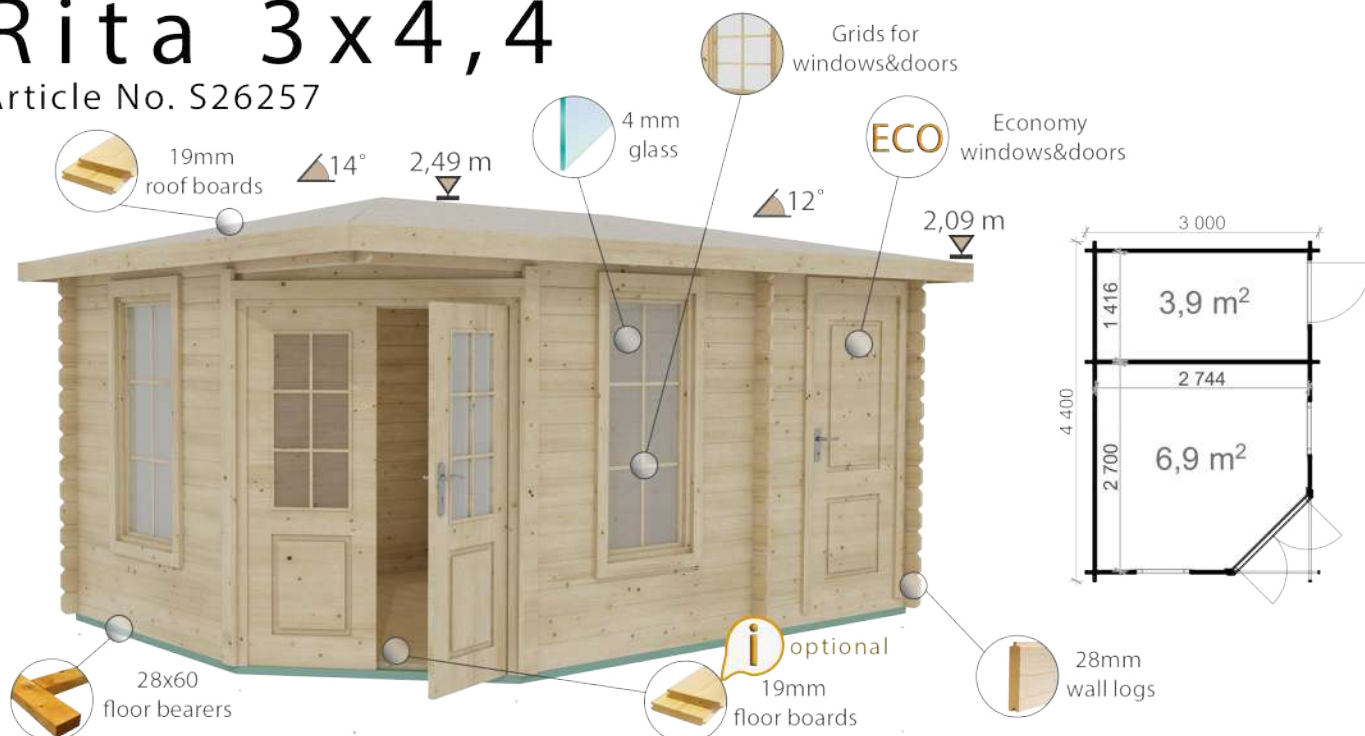

Project specification:

External measures: 3x4,4 m
Base footprint: 2,8x4,2 m
Internal house area: 10,8 m²
External wall area: 22 m²
Roof area: 15,6 m²

Windows and doors:

Door: 1 double 50% glass 1,85x1,4 m
and 1 single full wood 1,85x0,85 m
Window: 2 single 1,43x0,7 m
Threshold: covered with steel

Total height < 2,5 m:

Installation kit:

Storm braces:

*See optional products pages 26-27

Optional products

For shed/storage cabins

Name	Article No.	Dipping (pine colour)	Bitumen roof tiles	Underlayer	EPDM roof cover	Terrace
Alva 3x3	S26905	●	● 18m ²	● 18m'	●	● 3x1,5
Alva 3x4	S26199	●	● 21m ²	● 21m'	●	● 3x1,5
Alva 4x3	S26600	●	● 21m ²	● 22m'	●	● 4x1,5
Alva 4x4	S26200	●	● 27m ²	● 27m'	●	● 4x1,5
Atlanta 3,56x2,2	S26286	●	● 12m ²	● 11m'	●	
Bedford 2,2x2,2	S26201	●	● 9m ²	● 8m'	●	
Bedford 2,2x3	S26202	●	● 12m ²	● 10m'	●	
Elise 3x5,9	S26211	●	● 27m ²	● 24m'	●	
Emma 3x3	S26212	●	● 15m ²	● 13m'	●	● 3x1,5
Emma 4x3	S26213	●	● 18m ²	● 17m'	●	● 4x1,5
Erna 2,5x3,4	S26215	●	● 12m ²	● 12m'	●	
Genova 3,8x3	S26224	●	● 21m ²	● 20m'	●	
Imperial 3x3	S26232	●	● 18m ²	● 16m'	●	● 3x1,5
Kiosk 3x3	S26636	●	● 12m ²	● 12m'	●	
Kiosk 4x4	S26638	●	● 21m ²	● 20m'	●	
Mantova 2,5x2	S26244	●	● 9m ²	● 7m'	●	
Modena 3x2,5	S26247	●	● 15m ²	● 14m'	●	● 3x1,5
Megy 2,6x4,1	S26293	●	● 15m ²	● 15m'	●	
Osaka 3,2x3,2	S26294	●	● 18m ²	● 16m'	●	
Bogota 2,5x4	S26640	●	● 15m ²	● 13m'	●	
Edith 2,2x2,2	S26333	●	● 9m ²	● 7m'	●	
Edith 2x3	S26335	●	● 9m ²	● 9m'	●	
Edith 3x2	S26208	●	● 9m ²	● 9m'	●	
Edith 3x2,5	S26334	●	● 12m ²	● 11m'	●	
Edith 3x3	S26209	●	● 15m ²	● 13m'	●	
Lima 4,5x3	S26269	●	● 18m ²	● 17m'	●	
Toronto 3x3	S26295	●	● 12m ²	● 12m'	●	

Optional products

For shed/storage cabins

Name	Article No.	Dipping (pine colour)	Bitumen roof tiles	Underlayer	EPDM roof cover	Terrace
Dalás 2,6x2,6	S26288	●			● 8 m ²	
Eric 3,3x7,36	S26214	●			● 27 m ²	
Lulu-1 2,4x1,2	S26289	●			● 4 m ²	
Lulu-2 2,4x2,4	S26290	●			● 7 m ²	
Lulu-3 3,4x2,4	S26291	●			● 9 m ²	
Madrid 2,14x2,15	S26292	●			● 6 m ²	
Amarillo 3x5,96	S28114	●	● 27 m ²	● 25 m'		
Colombo 2,6x2,6	S26239	●	● 15 m ²	● 10 m'		
Lukné 3x3	S16294	●	● 18 m ²	● 12 m'		
Rita 3x4,4		●	● 21 m ²	● 17 m'		

Garden house



Gable roof



Flat roof

Gable roof p.30-57



Deko 5x3
p.30



Eko 5x5,7
p.31



Elise 3x5,9
p.32



Erna series
p.33



Hakan A 6x5,2
p.34



Hakan B 7x7,19
p.35



Helmand 3x9
p.36



Linus 4 series
p.37



Linus 5 series
p.39



Linus 6 series
p.41



Linus 5 WC series
p.44



Linus 6 WC series
p.46



Milano 3,8x3,8
p.47



Murray 4x6
p.48



Oslo 3x6
p.49



Padova A 6x4,5
p.50



Padova B 6x6,5
p.51



Roberto 5,6x4
p.52



Scandi 3,7x6,9
p.53



Suzy 3,2x6
p.54



Torino 4,5x6
p.55



Trento 6x5
p.57

Flat roof p.58-61



Eric 3,3x7,36
p.58



Eric 3x2,5 no canopy
p.59



Ottawa 6x4,5
p.60



Rico 4,04x7,8
p.61

Deko 5x3

Premium - Article No. S26206

Economy - Article No. S27438

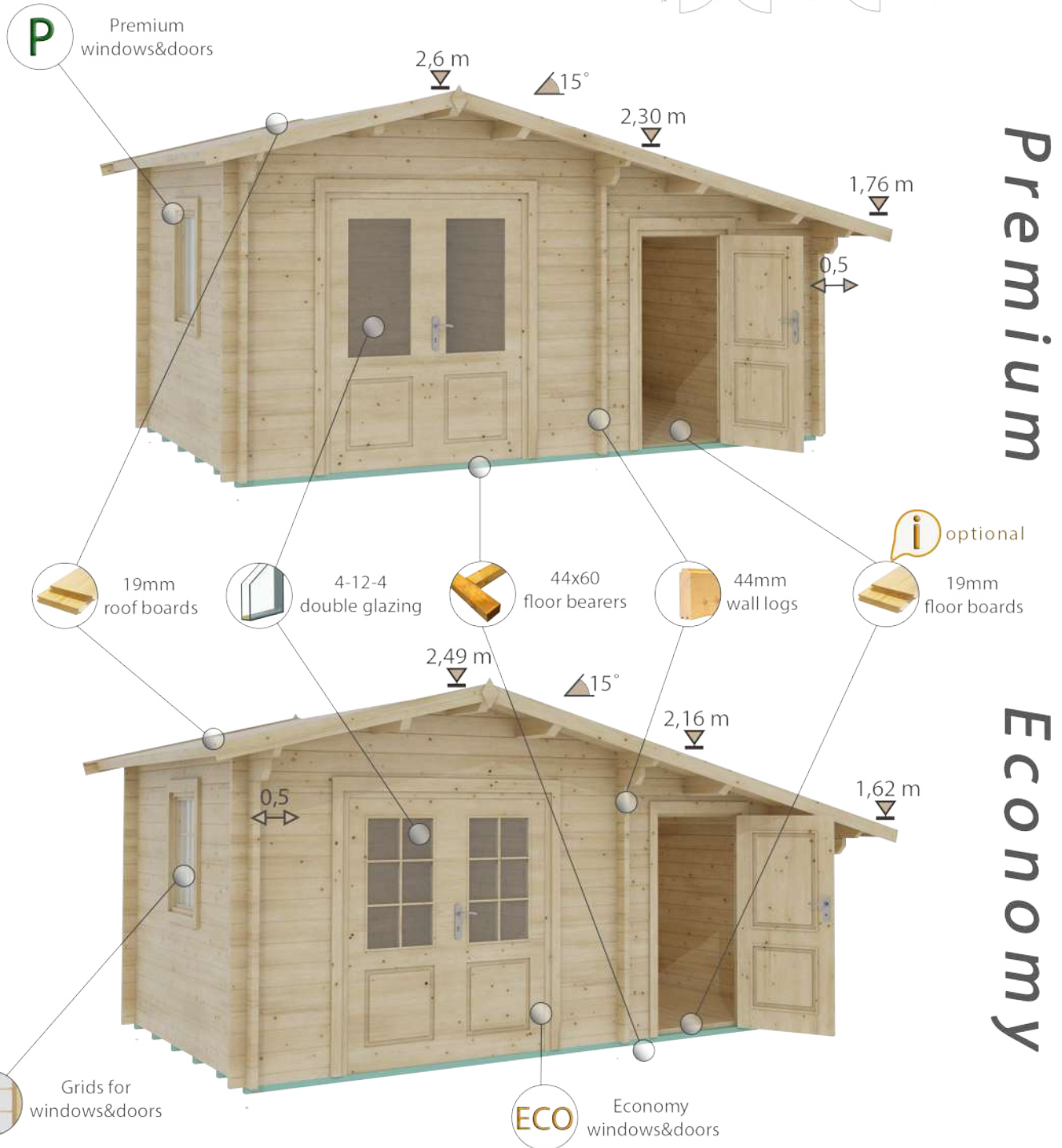
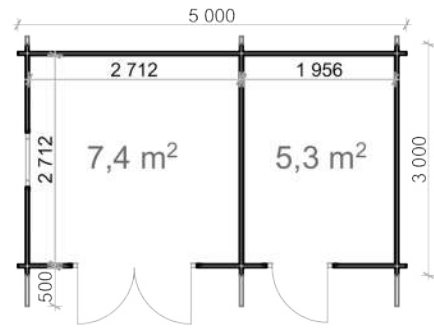

Premium

Economy

Project specification:

External measures: 5x3 m
 Base footprint: 4,8x2,8 m
 Internal house area: 12,7 m²
 External wall area:
 Premium - 30,3 m²
 Economy - 28,3 m²
 Roof area: 19,2 m²

Windows and doors:

Door:
 Premium - 1 double 50% glass 1,98x1,6 m
 and 1 single full wood 1,7x0,85 m
 Economy - 1 double 50% glass 1,85x1,6 m
 and 1 single full wood 1,7x0,85 m
Window: 1 single 0,92x0,7 m
Threshold: covered with steel

Total height <2,5 m:

(Economy only)
Installation kit:
Storm braces:

*See optional products pages 62-63

Eko 5x5,7

Premium - Article No. S26210

Economy - Article No. S27443

Premium

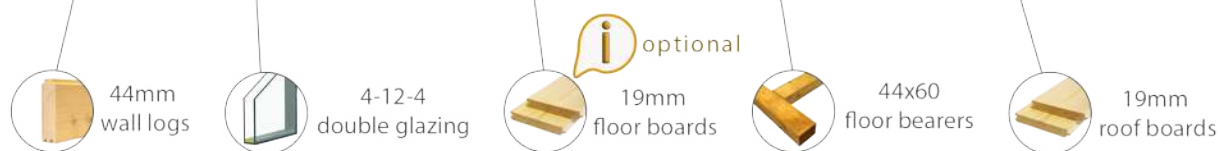
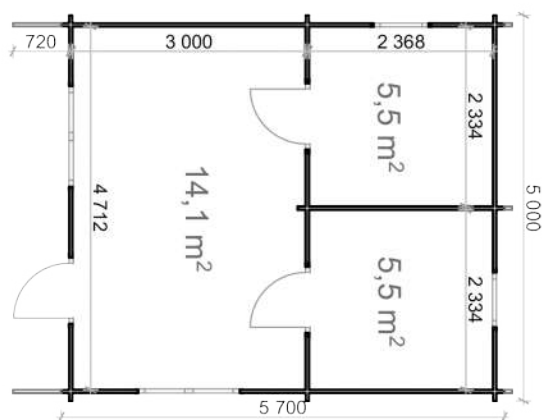

Economy



Project specification:

External measures: 5x5,7 m
 Base footprint: 4,8x5,5 m
 Internal house area: 25,1 m²
 External wall area:
 Premium - 43 m²
 Economy - 40,3 m²
 Roof area: 35,4 m²

Windows and doors:

Door:
 Premium - 1 single 50% glass 1,98x0,85 m and 2 single full wood 1,98x0,85 m
 Economy - 1 single 50% glass 1,85x0,85 m and 2 single full wood 1,85x0,85 m
Window: 2 single 0,92x0,7 m and 2 double 0,92x1,3 m
Threshold: covered with steel

Possible reverse montage:

Installation kit:

Storm braces:

*See optional products pages 62-63

Elise 3x5,9

Premium - Article No. S26352

Economy - Article No. S27445

 Economy version available 28mm
*see page 11th

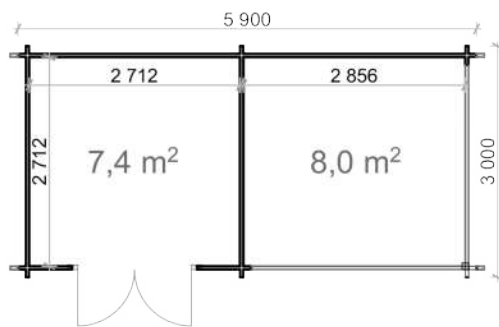

Premium

-  19mm roof boards
-  4-12-4 double glazing
-  optional 19mm floor boards
-  44x60 floor bearers
-  28mm terrace boards
-  44mm wall logs



Economy

-  Grids for windows&doors
-  **ECO** Economy windows&doors

Project specification:

External measures: 3x5,9 m

Base footprint: 2,8x5,7 m

Internal house area: 7,4 m²

Terrace area: 8 m²

External wall area:

Premium - 35,4 m²

Economy - 33,5 m²

Roof area: 21,7 m²

Windows and doors:

Door:

Premium - 1 double 50% glass 1,98x1,6 m

Economy - 1 double 50% glass 1,85x1,6 m

Threshold: covered with steel

Installation kit:

Storm braces:

*See optional products pages 62-63

Erna series

Erna 2,5x3,4

Premium-Article No. S27449
Economy-Article No. S27450

Project specification:

External measures: 2,5x3,4 m
Base footprint: 2,3x3,2 m
Internal house area: 6,9 m²
External wall area:
Premium - 23,6 m²
Economy - 22,2 m²
Roof area: 10,6 m²

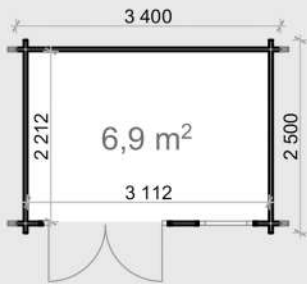

i Economy version
available 28mm
*see page 14th

Premium

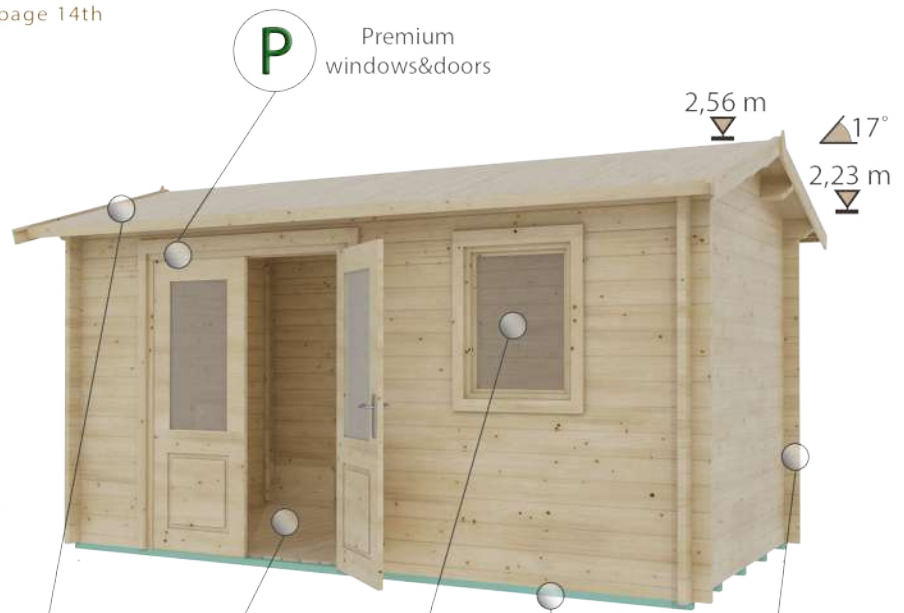

P Premium windows&doors

2,56 m
2,23 m
17°

Erna 2,5x4,5

Premium-Article No. S26216
Economy-Article No. S26922

Project specification:

External measures: 2,5x4,5 m
Base footprint: 2,3x4,3 m
Internal house area: 9,3 m²
External wall area:
Premium - 28,5 m²
Economy - 26,8 m²
Roof area: 12,3 m²

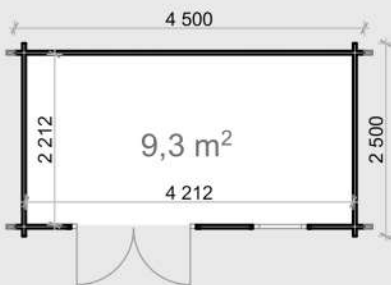

Economy

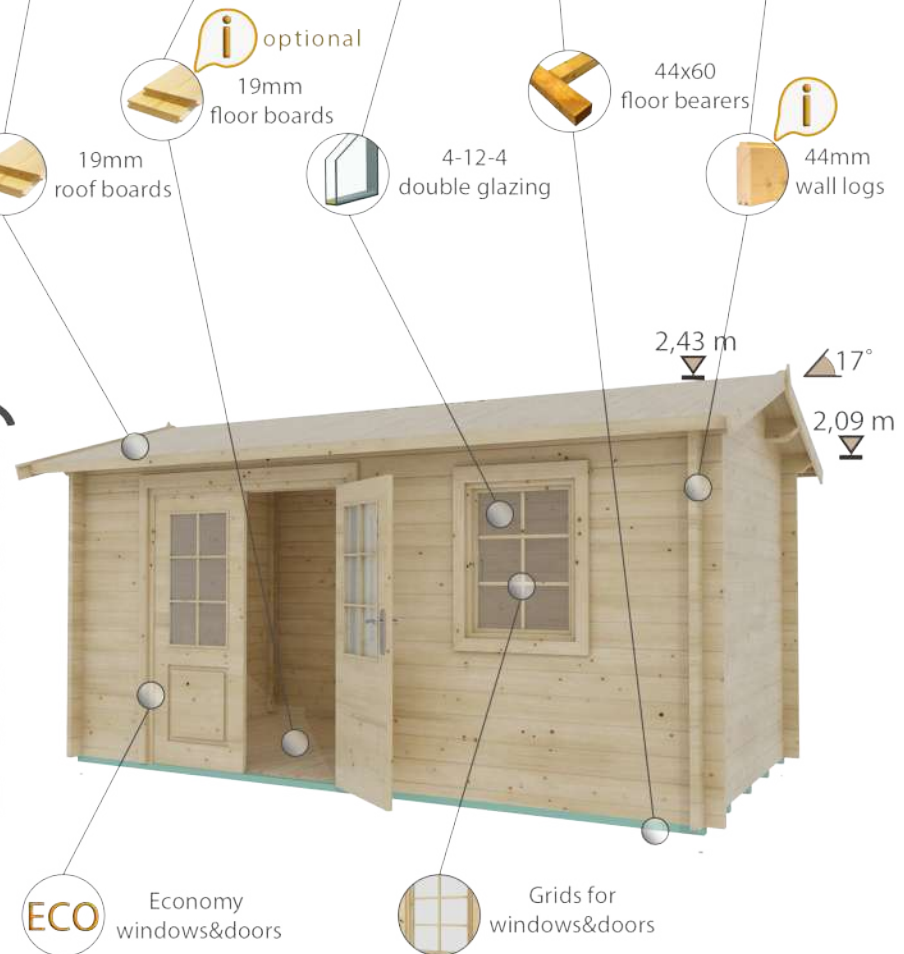

ECO Economy windows&doors

Grids for windows&doors

2,43 m
2,09 m
17°

i optional
19mm floor boards

44x60 floor bearers
i 44mm wall logs

19mm roof boards

4-12-4 double glazing

Windows and doors:

Door:
Premium - 1 double 50% glass 1,98x1,6 m
Economy - 1 double 50% glass 1,85x1,6 m
Window: 1 single 0,92x0,7 m
Threshold: covered with steel

Total height <2,5 m:

- (Economy only)
- Possible reverse montage:**
- Installation kit:**
- Storm braces:**

*See optional products pages 62-63

Hakan A 6x5,2

Premium - Article No. S26228

Economy - Article No. S26742

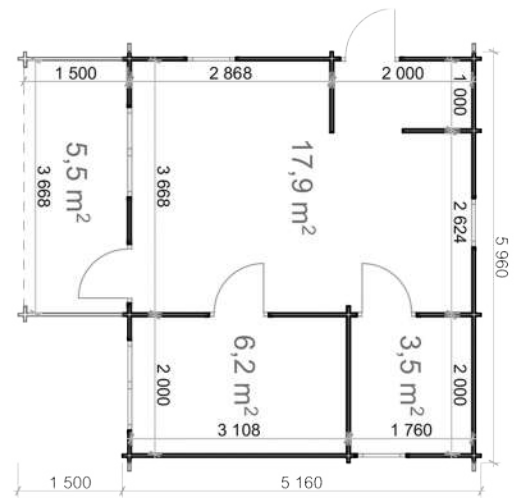

Garden house
gabled roof

30-57

Premium

Economy

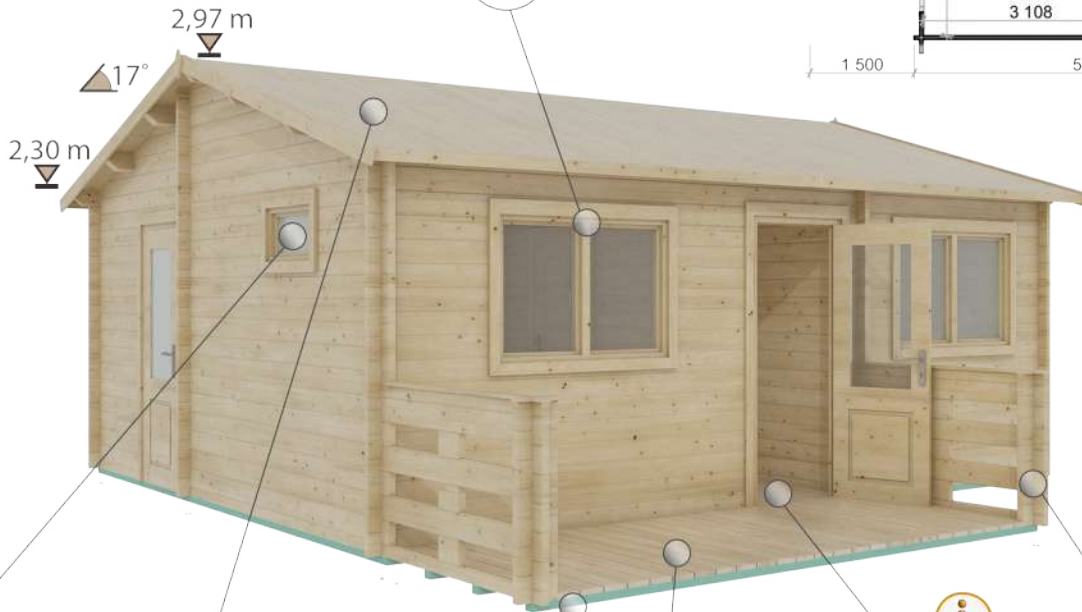

P Premium windows&doors

- 4-12-4 double glazing
- 19mm roof boards
- 44x60 floor bearers
- 28mm terrace boards
- optional 19mm floor boards
- 44mm wall logs



ECO Economy windows&doors

Grids for windows&doors

Project specification:

External measures: 5,96x5,16 m

Base footprint: 5,8x5 m

Internal house area: 27,6 m²

Terrace area: 5,5 m²

External wall area:

Premium - 50,3 m²

Economy - 47,2 m²

Roof area: 35,6 m²

Windows and doors:

Door:

Premium - 2 single 50% glass 1,98x0,85 m and 2 single full wood 1,98x0,85 m

Economy - 2 single 50% glass 1,85x0,85 m and 2 single full wood 1,85x0,85 m

Window: 2 double 0,92x1,3 m and 3 single 0,39x0,7 m

Threshold: covered with steel

Installation kit:

*See optional products pages 62-63

Hakan B 7x7,19

Premium - Article No. S24190

Economy - Article No. S26743

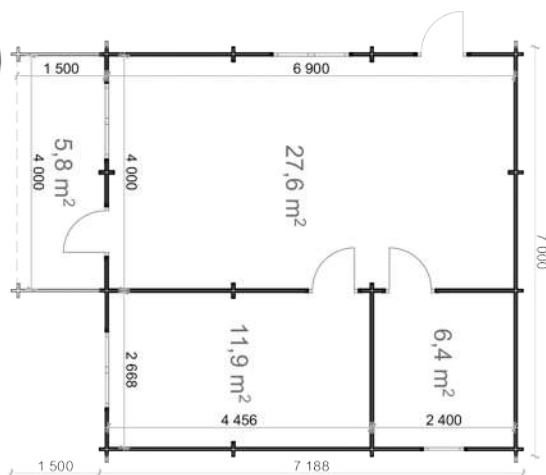

Garden house
gabled roof

Premium

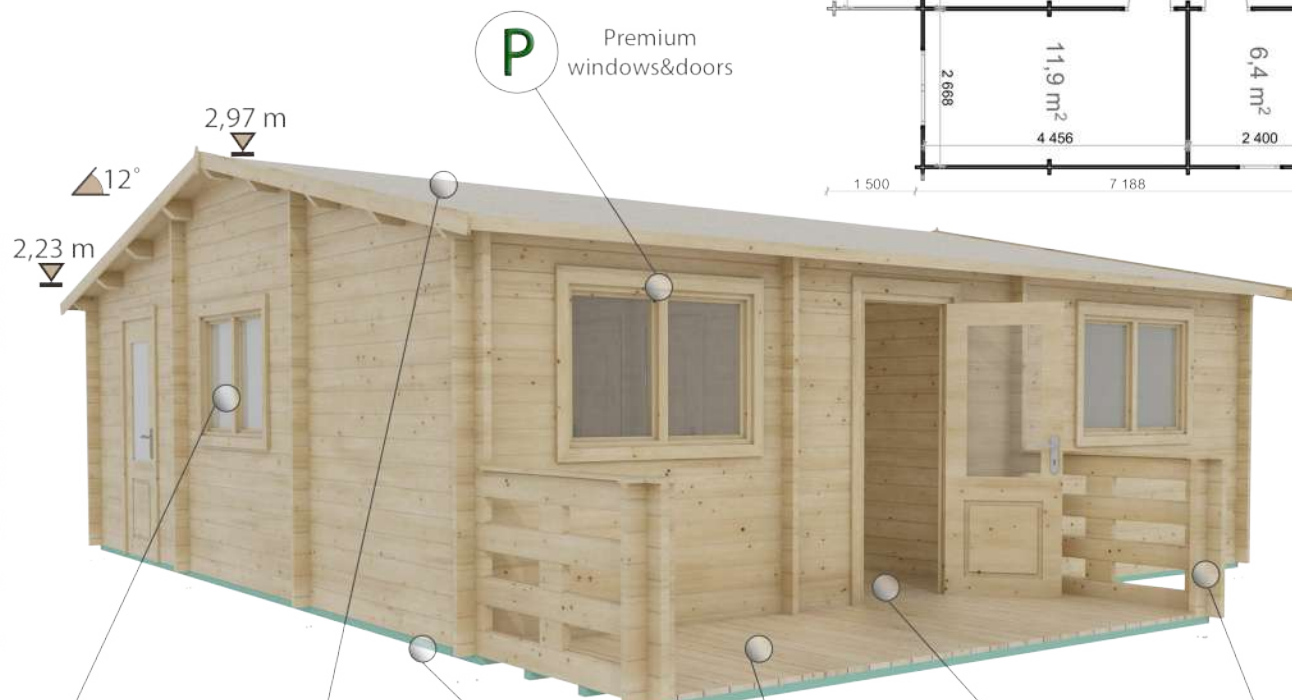

Economy

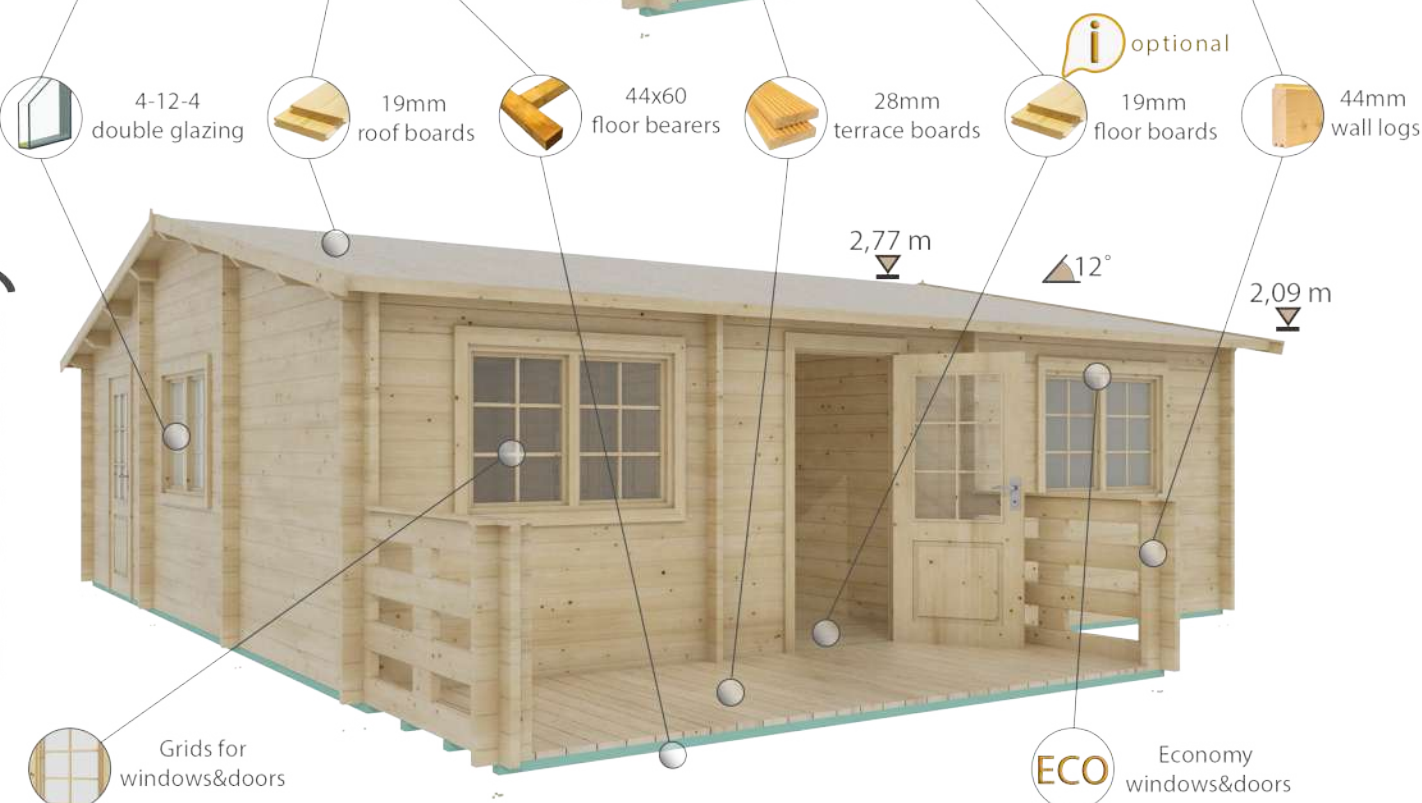

Project specification:

External measures: 7x7,19 m

Base footprint: 6,8x6,99 m

Internal house area: 45,9 m²

Terrace area: 5,8 m²

External wall area:

Premium - 65 m²

Economy - 62 m²

Roof area: 55,2 m²

Windows and doors:

Door:

Premium - 2 single 50% glass 1,98x0,85 m

and 2 single full wood 1,98x0,85 m

Economy - 2 single 50% glass 1,85x0,85 m

and 2 single full wood 1,85x0,85 m

Window: 3 double 0,92x1,3 m and

1 single 0,39x0,7 m

Threshold: covered with steel

Installation kit:

*See optional products pages 62-63

Helmand 3x9

Premium - Article No. S26196

Economy - Article No. S26935

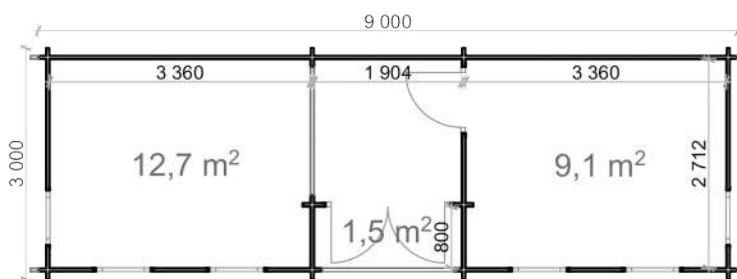

P Premium windows&doors



Premium

Garden house
gabled roof

30-57

- 19mm roof boards
- 4-12-4 double glazing
- 44x60 floor bearers
- 19mm floor boards
- 28mm terrace boards
- 44mm wall logs

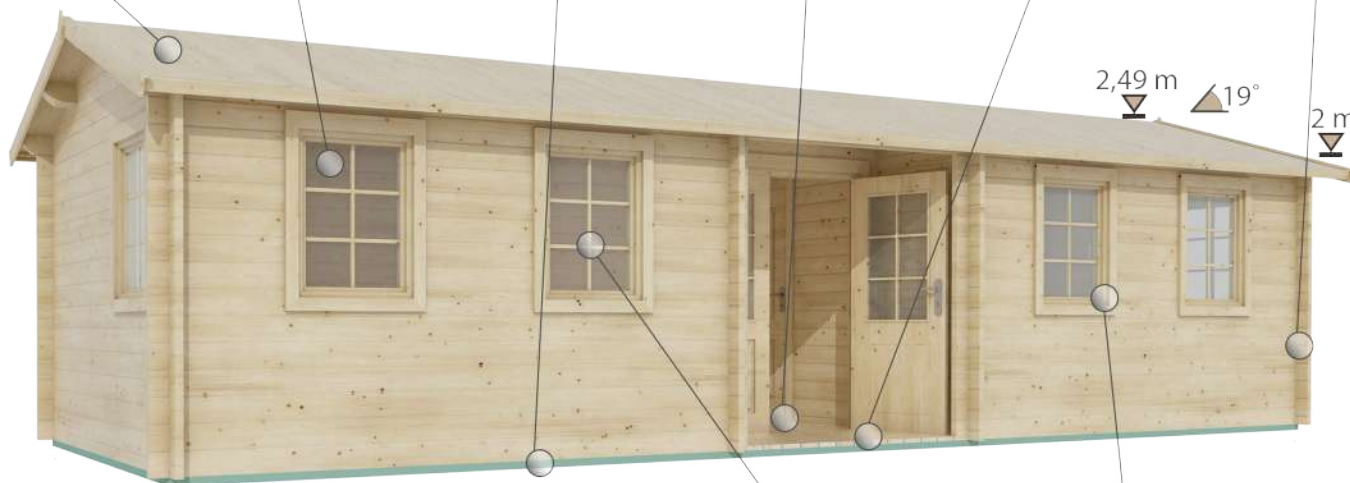

Economy

- Grids for windows&doors
- ECO** Economy windows&doors

Project specification:

External measures: 3x9 m
 Base footprint: 2,8x8,8 m
 Internal house area: 21,8 m²
 Terrace area: 1,5 m²
 External wall area:
 Premium - 55 m²
 Economy - 51,8 m²
 Roof area: 32,2 m²

Windows and doors:

Door:
 Premium - 1 double 50% glass 1,98x1,6 m and 1 single full wood 1,98x0,85 m
 Economy - 1 double 50% glass 1,85x1,6 m and 1 single full wood 1,85x0,85 m
Window: 6 single 0,92x0,7 m
Threshold: covered with steel

Total height <2,5 m:

- (Economy only)
- Possible reverse montage:**
- Installation kit:**
- Storm braces:**

*See optional products pages 62-63

Linus 4 series

Premium



19mm
roof boards

44mm
wall logs

4-12-4
double glazing

44x60
floor bearers

i optional
19mm
floor boards

Economy

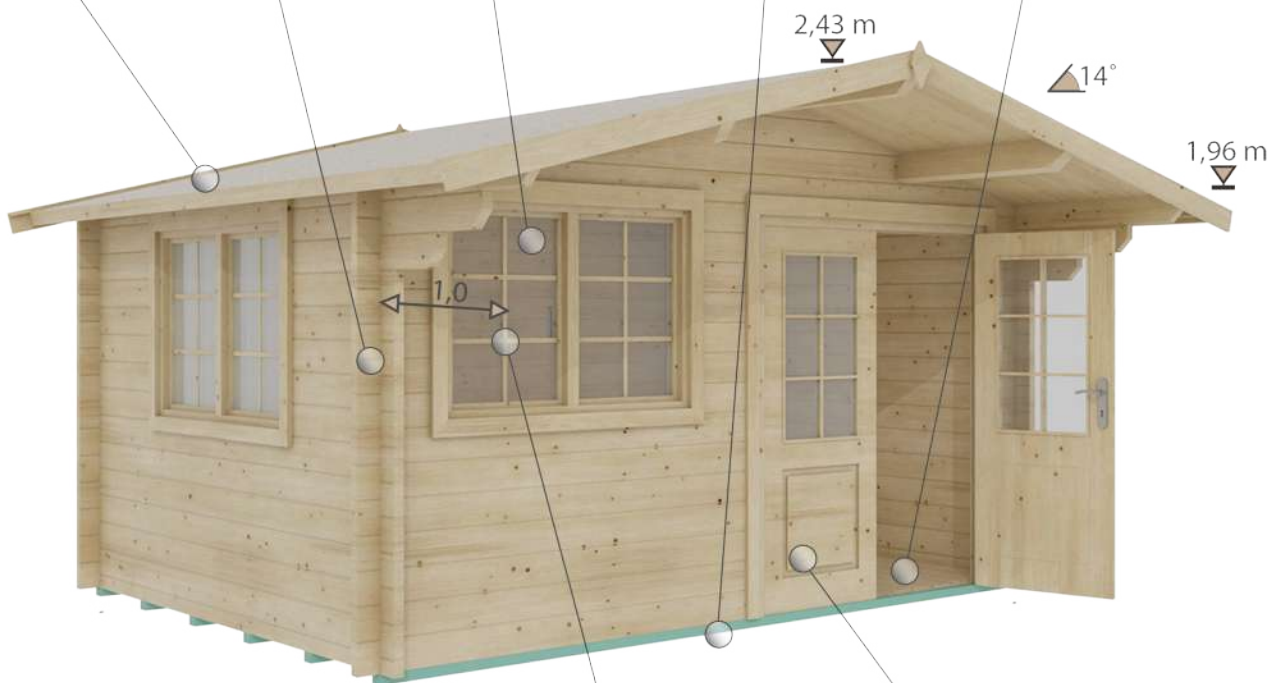

Grids for
windows&doors

ECO Economy
windows&doors

Linus 4x3

Premium-Article No. S26755

Economy-Article No. S26757

Project specification:

External measures: 4x3 m

Base footprint: 3,8x2,8 m

Internal house area: 10,1 m²

External wall area:

Premium - 26,3 m²

Economy - 24,7 m²

Roof area: 17,8 m²

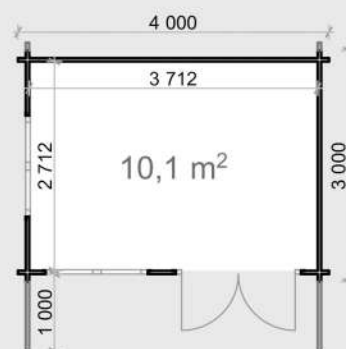

Linus 4x4

Premium-Article No. S26233

Economy-Article No. S26760

Project specification:

External measures: 4x4 m

Base footprint: 3,8x3,8 m

Internal house area: 13,8 m²

External wall area:

Premium - 30,5 m²

Economy - 28,6 m²

Roof area: 22,2 m²



Linus 4x5

Premium-Article No. S26234

Economy-Article No. S26754

Project specification:

External measures: 4x5 m

Base footprint: 3,8x4,8 m

Internal house area: 17,5 m²

External wall area:

Premium - 34,7 m²

Economy - 32,5 m²

Roof area: 26,7 m²



Windows and doors:

Door:

Premium - 1 double 50% glass 1,98x1,6 m

Economy - 1 double 50% glass 1,85x1,6 m

Window: 2 double 0,92x1,3 m

Threshold: covered with steel

Total height < 2,5 m:

Possible reverse montage:

Installation kit:

Storm braces:

*See optional products pages 62-63

Linus 5 series

Premium



P Premium windows&doors

2,7 m

15°

2,09 m

1,0

19mm roof boards

44mm wall logs

4-12-4 double glazing

44x60 floor bearers

i optional
19mm floor boards

Economy

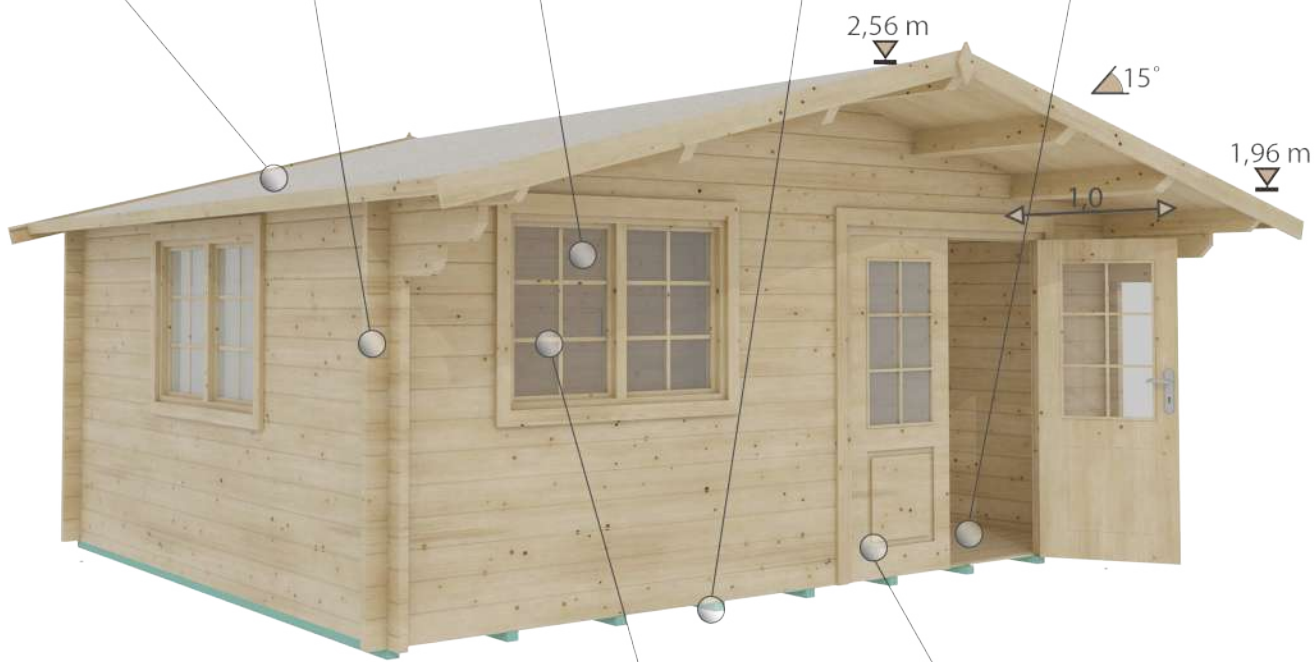

2,56 m

15°

1,96 m

1,0

Grids for windows&doors

ECO Economy windows&doors

Linus 5x4

Premium-Article No. S26235

Economy-Article No. S26764

Project specification:

External measures: 5x4 m

Base footprint: 4,8x3,8 m

Internal house area: 17,5 m²

External wall area:

Premium - 36 m²

Economy - 33,7 m²

Roof area: 27,4 m²

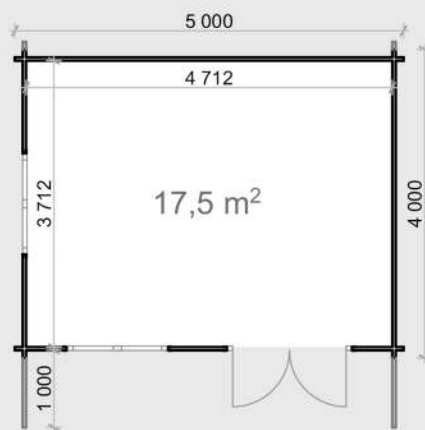

Linus 5x5

Premium-Article No. S26236

Economy-Article No. S26763

Project specification:

External measures: 5x5 m

Base footprint: 4,8x4,8 m

Internal house area: 22,2 m²

External wall area:

Premium - 40,2 m²

Economy - 37,7 m²

Roof area: 32,9 m²



Linus 5x6

Premium-Article No. S26758

Economy-Article No. S26759

Project specification:

External measures: 4,96x5,96 m

Base footprint: 4,8x5,8 m

Internal house area: 26,9 m²

External wall area:

Premium - 44 m²

Economy - 41,3 m²

Roof area: 38,3 m²

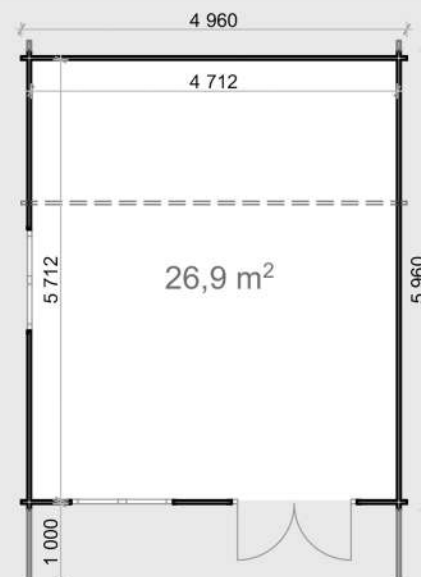

Windows and doors:

Door:

Premium - 1 double 50% glass 1,98x1,6 m

Economy - 1 double 50% glass 1,85x1,6 m

Window: 2 double 0,92x1,3 m

Threshold: covered with steel

Possible reverse montage:

Installation kit:

Storm braces:

*See optional products pages 62-63

Linus 6 series

Premium

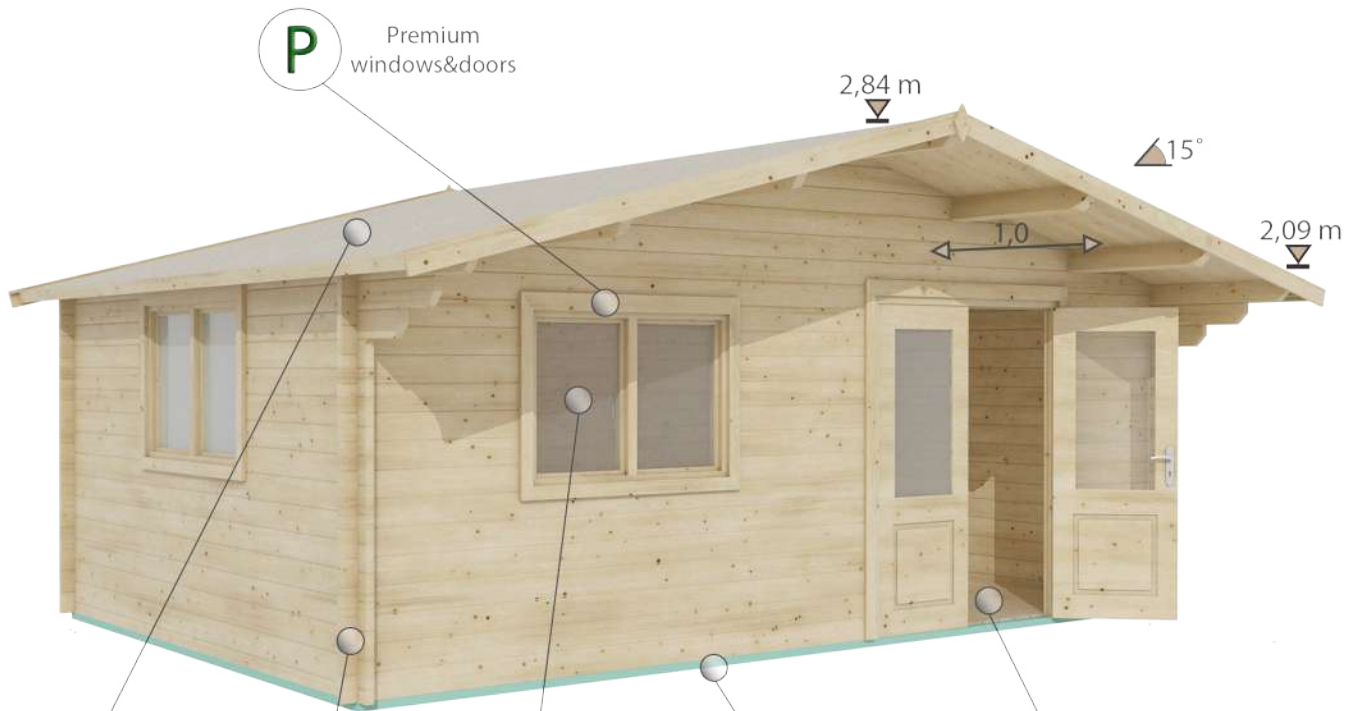

P Premium windows&doors

2,84 m

15°

2,09 m

1,0

19mm roof boards

44mm wall logs

4-12-4 double glazing

44x60 floor bearers

i optional
19mm floor boards

Economy

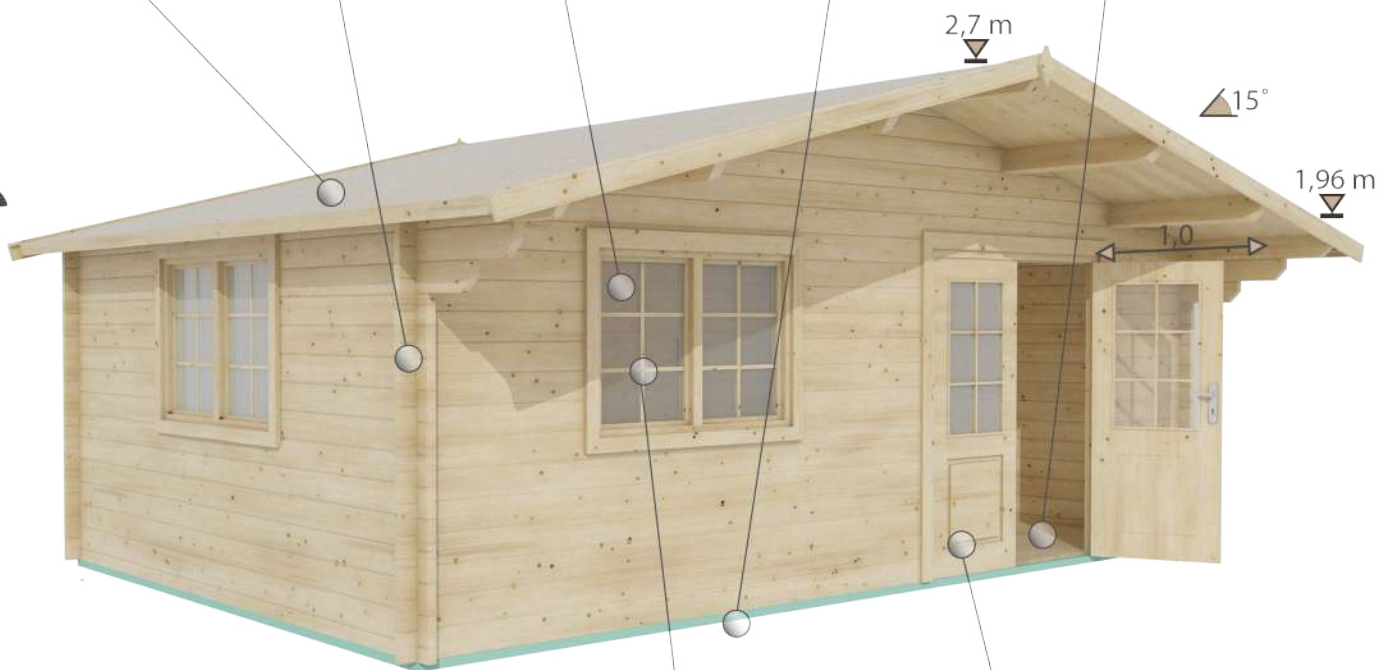

2,7 m

15°

1,96 m

1,0

Grids for windows&doors

ECO Economy windows&doors

Linus 6x4

Premium-Article No. S27466

Economy-Article No. S27465

Project specification:

External measures: 5,96x3,96 m

Base footprint: 5,8x3,8 m

Internal house area: 21,2 m²

External wall area:

Premium - 41,4 m²

Economy - 39 m²

Roof area: 32,6 m²

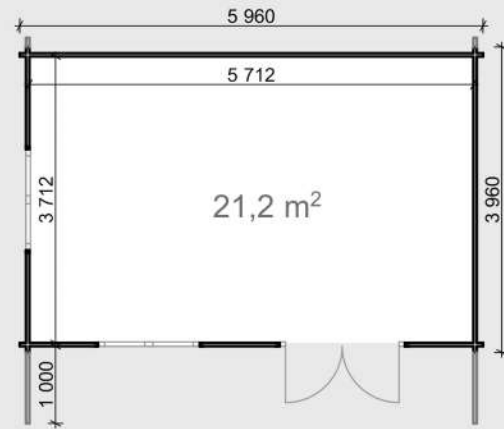

Linus 6x5

Premium-Article No. S27463

Economy-Article No. S27464

Project specification:

External measures: 5,96x4,96 m

Base footprint: 5,8x4,8 m

Internal house area: 26,9 m²

External wall area:

Premium - 45,5 m²

Economy - 42,6 m²

Roof area: 39,1 m²

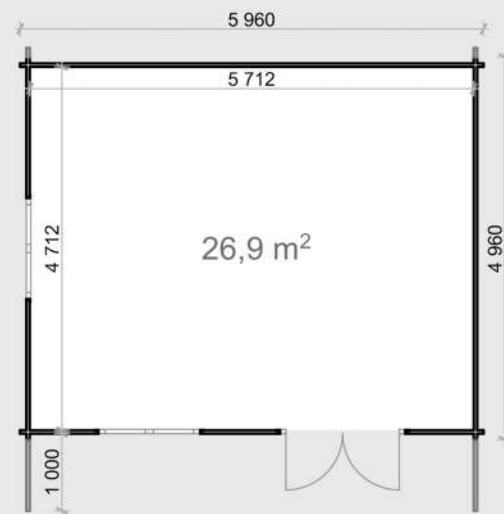

Linus 6x6

Premium-Article No. S26237

Economy-Article No. S26766

Project specification:

External measures: 5,96x5,96 m

Base footprint: 5,8x5,8 m

Internal house area: 32,6 m²

External wall area:

Premium - 49,7 m²

Economy - 46,7 m²

Roof area: 45,6 m²



Windows and doors:

Door:

Premium - 1 double 50% glass 1,98x1,6 m

Economy - 1 double 50% glass 1,85x1,6 m

Window: 2 double 0,92x1,3 m

Threshold: covered with steel

Possible reverse montage:

Installation kit:

Storm braces:

*See optional products pages 62-63

Linus 5 WC series

Premium

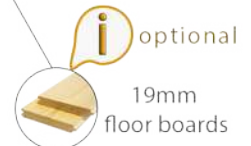
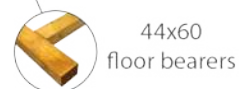
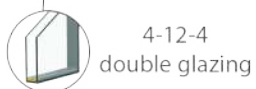

Economy

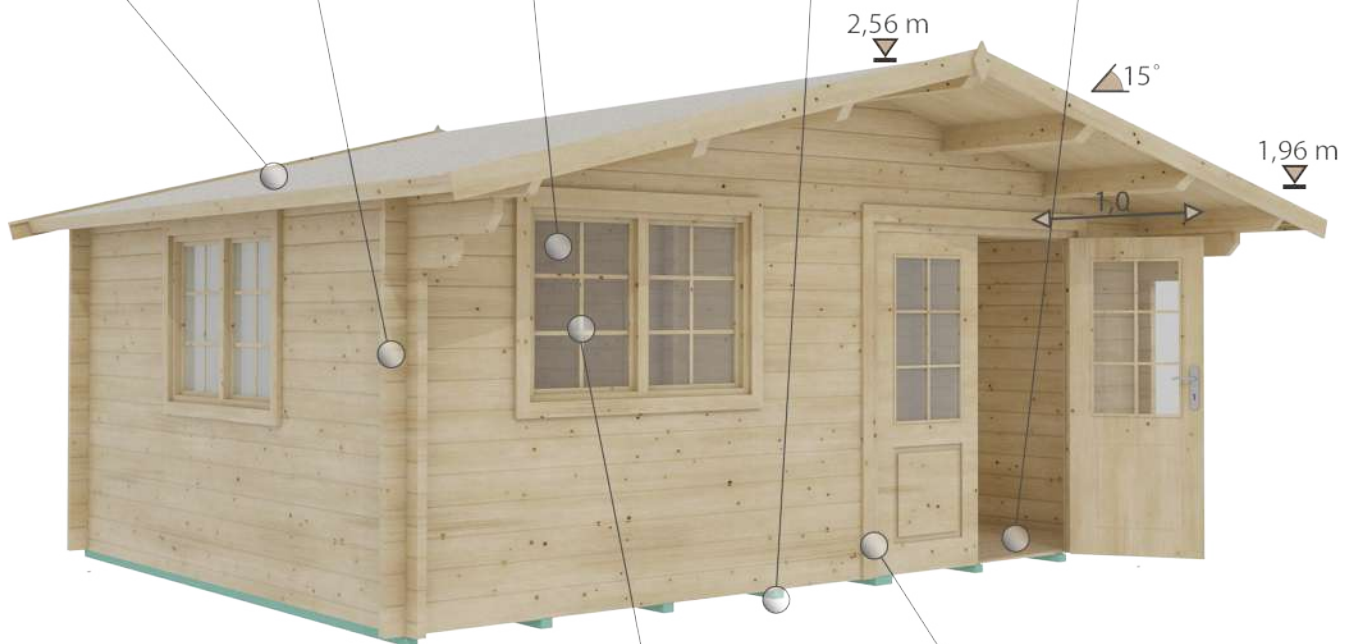

Linus 5x4 WC

Premium-Article No. S26771

Economy-Article No. S28440

Project specification:

External measures: 5x4 m

Base footprint: 4,8x3,8 m

Internal house area: 17,3 m²

External wall area:

Premium - 36 m²

Economy - 33,7 m²

Roof area: 27,4 m²

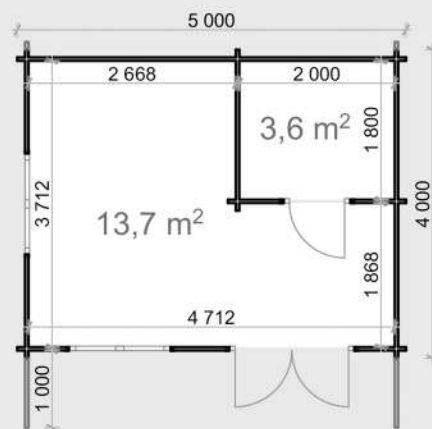

Linus 5x5 WC

Premium-Article No. S26773

Economy-Article No. S28442

Project specification:

External measures: 5x5 m

Base footprint: 4,8x4,8 m

Internal house area: 22 m²

External wall area:

Premium - 40,2 m²

Economy - 37,7 m²

Roof area: 32,9 m²



Windows and doors:

Door:

Premium - 1 double 50% glass 1,98x1,6 m and 1 single full wood 1,85x0,85

Economy - 1 double 50% glass 1,85x1,6 m and 1 single full wood 1,85x0,85

Window: 2 double 0,92x1,3 m and 1 single 0,52x0,5

Threshold: covered with steel

Possible reverse montage:

Installation kit:

Storm braces:

*See optional products pages 62-63

Linus 6 WC series

Premium

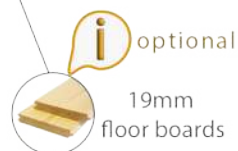
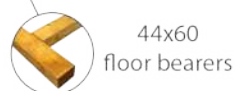
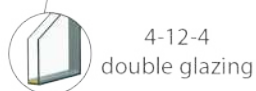
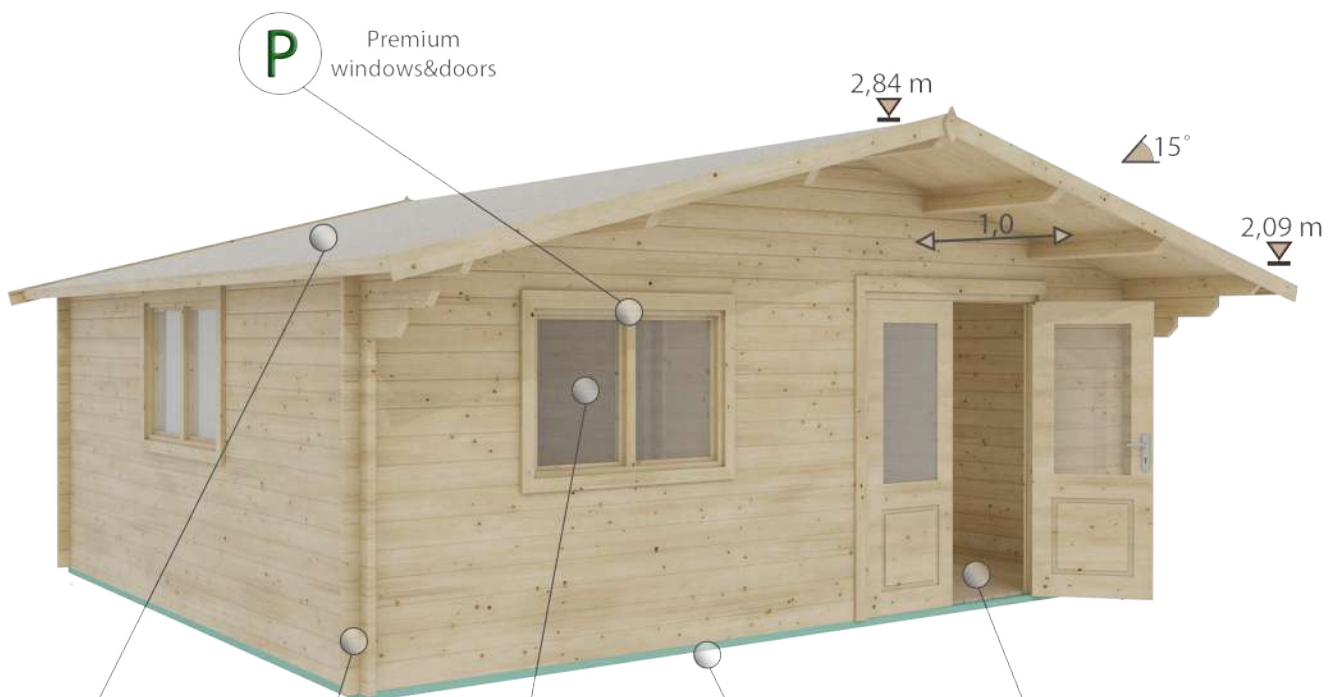

Economy

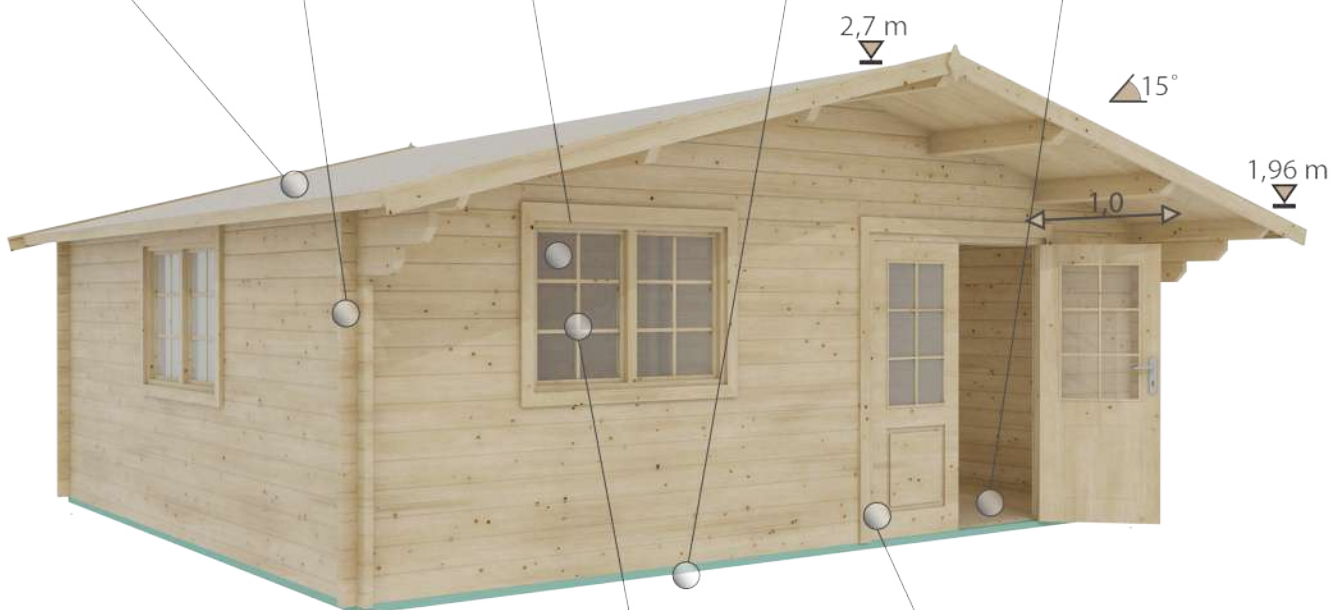

Linus 6x5 WC

Premium-Article No. S26774

Economy-Article No. S28441

Project specification:

External measures: 5,96x4,96 m

Base footprint: 5,8x4,8 m

Internal house area: 26,7 m²

External wall area:

Premium - 45,5 m²

Economy - 42,6 m²

Roof area: 39,1 m²



Linus 6x6 WC

Premium-Article No. S26238

Economy-Article No. S26767

Project specification:

External measures: 5,96x5,96 m

Base footprint: 5,8x5,8 m

Internal house area: 32,4 m²

External wall area:

Premium - 49,7 m²

Economy - 46,7 m²

Roof area: 45,6 m²

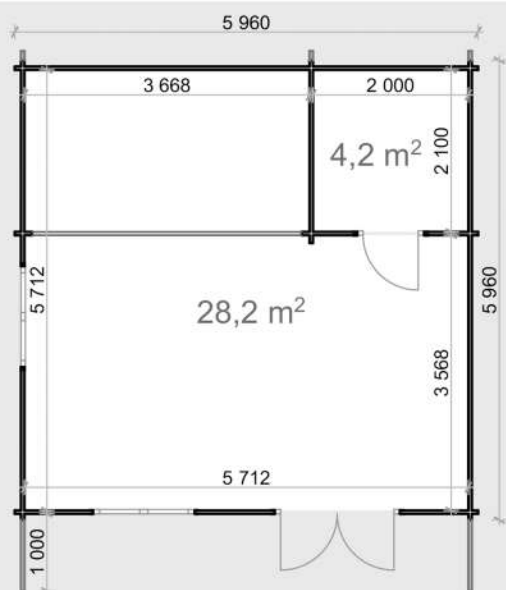

Windows and doors:

Door:

Premium - 1 double 50% glass 1,98x1,6 m and 1 single full wood 1,85x0,85

Economy - 1 double 50% glass 1,85x1,6 m and 1 single full wood 1,85x0,85

Window: 2 double 0,92x1,3 m and 1 single 0,52x0,5

Threshold: covered with steel

Possible reverse montage:

Installation kit:

Storm braces:

*See optional products pages 62-63

Milano 3,8x5,3

Premium - Article No. S26781

Economy - Article No. S26782

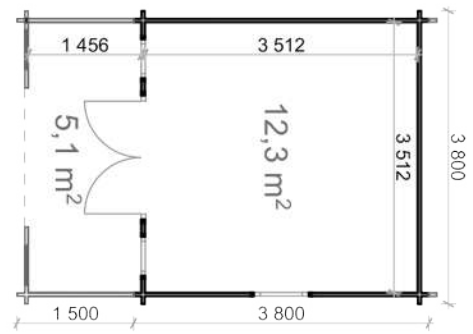

Premium

Economy

P Premium windows&doors



44mm wall logs

4-12-4 double glazing

28mm terrace boards

i optional 19mm floor boards

44x60 floor bearers

19mm roof boards

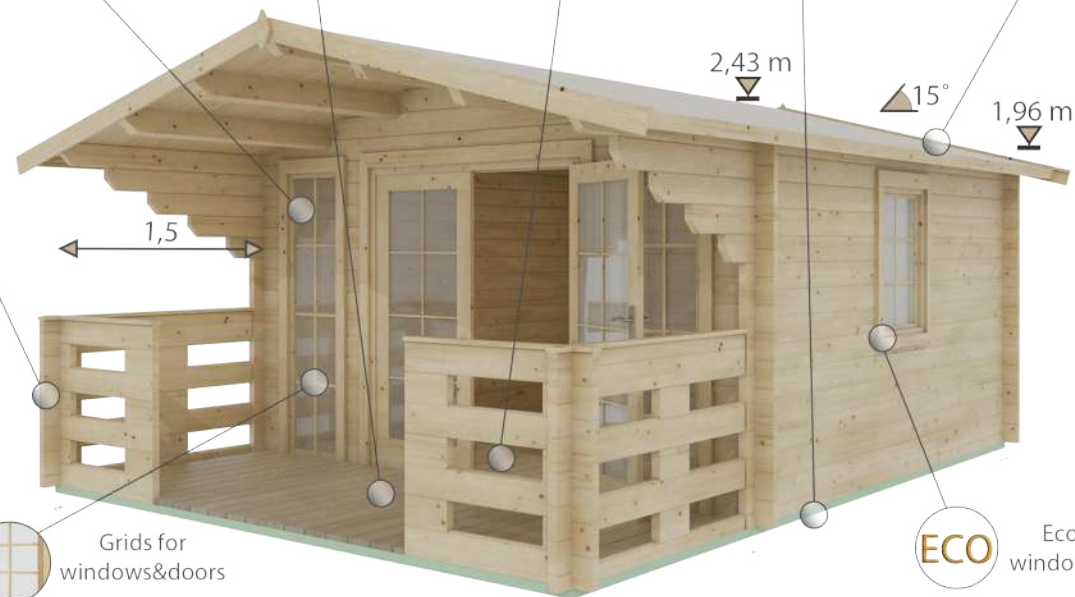

Grids for windows&doors

ECO Economy windows&doors

Project specification:

External measures: 3,8x5,3 m

Base footprint: 3,6x5,1 m

Internal house area: 12,3 m²

Terrace area: 5,1 m²

External wall area:

Premium - 32,6 m²

Economy - 30,9 m²

Roof area: 22,5 m²

Windows and doors:

Door:

Premium - 1 double 100% glass 1,98x1,6 m

Economy - 1 double 100% glass 1,85x1,6 m

Window:

Premium - 1 single 0,92x0,7 m and 2 single 1,98x0,5 m

Economy - 1 single 0,92x0,7 m and 2 single 1,85x0,5 m

Threshold: covered with steel

Total height <2,5 m:

(Economy only)

Possible reverse montage:

Installation kit:

Storm braces:

*See optional products pages 62-63

Murray 4x6

Premium - Article No. S26936

Economy - Article No. S26248

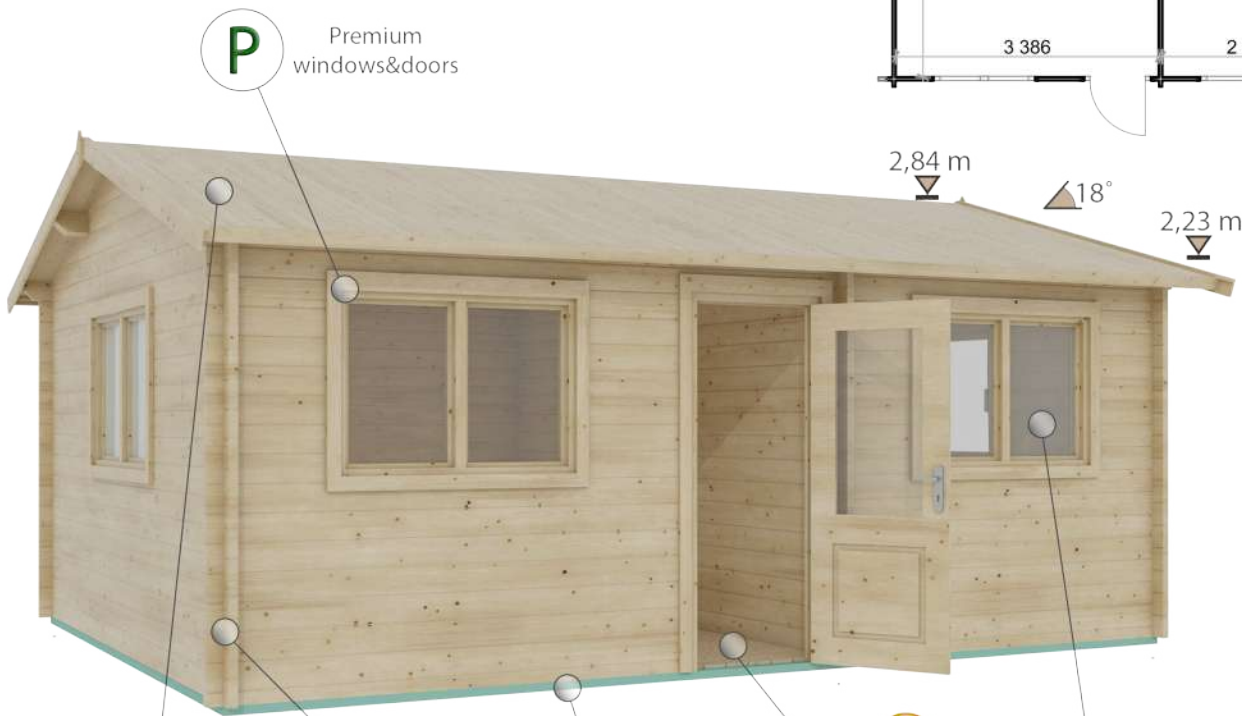
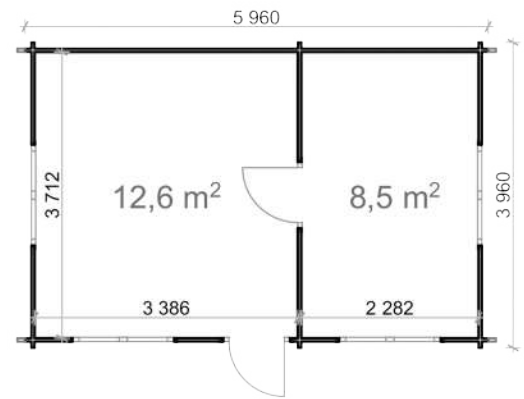

2,84 m
18°
2,23 m

Premium

Garden house
gabled roof

30-57

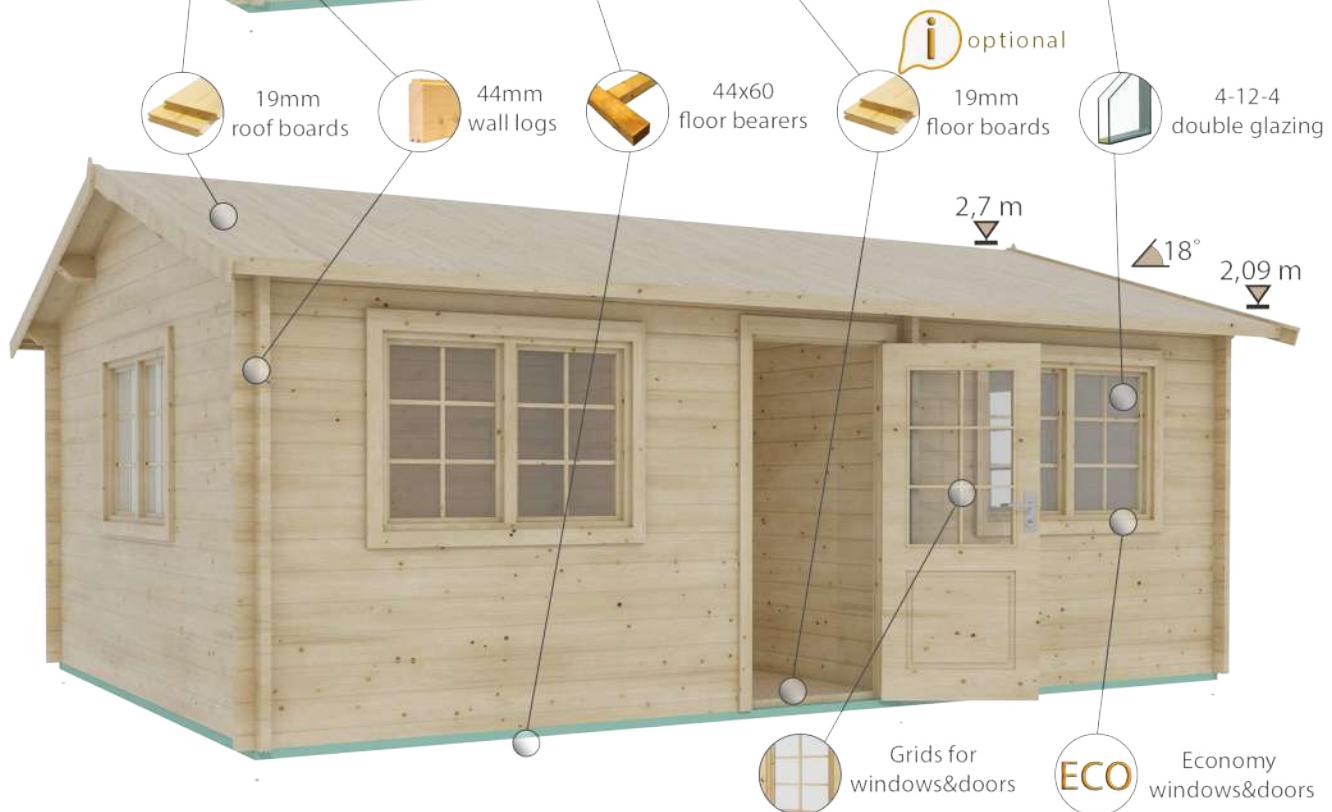

2,7 m
18°
2,09 m

Economy

Project specification:

External measures: 3,96x5,96 m

Base footprint: 3,8x5,8 m

Internal house area: 21,1 m²

External wall area:

Premium - 40,7 m²

Economy - 38,2 m²

Roof area: 28,1 m²

Windows and doors:

Door:

Premium - 1 single 50% glass 1,98x0,85 m and 1 single full wood 1,98x0,85 m

Economy - 1 single 50% glass 1,85x0,85 m and 1 single full wood 1,85x0,85 m

Window: 4 double 0,92x1,3 m

Threshold: covered with steel

Possible reverse montage:

Installation kit:

Storm braces:

*See optional products pages 62-63

Oslo 3x6

Premium - Article No. S26270

Economy - Article No. S26937

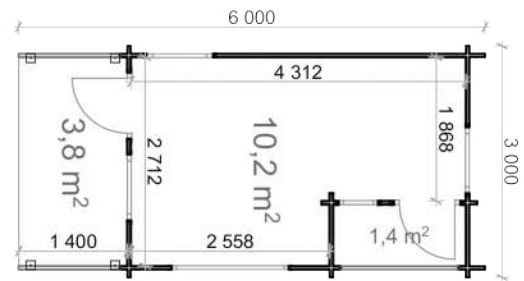

Premium

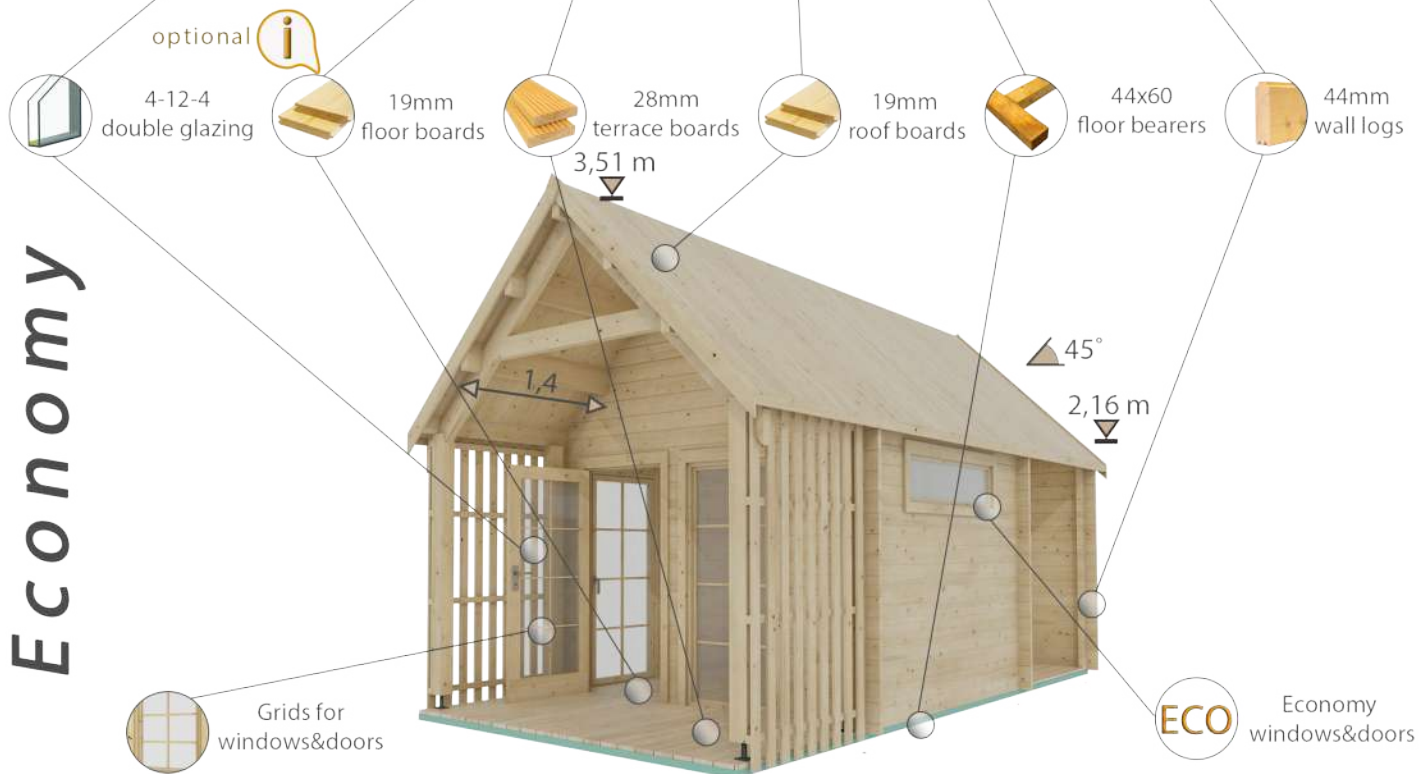
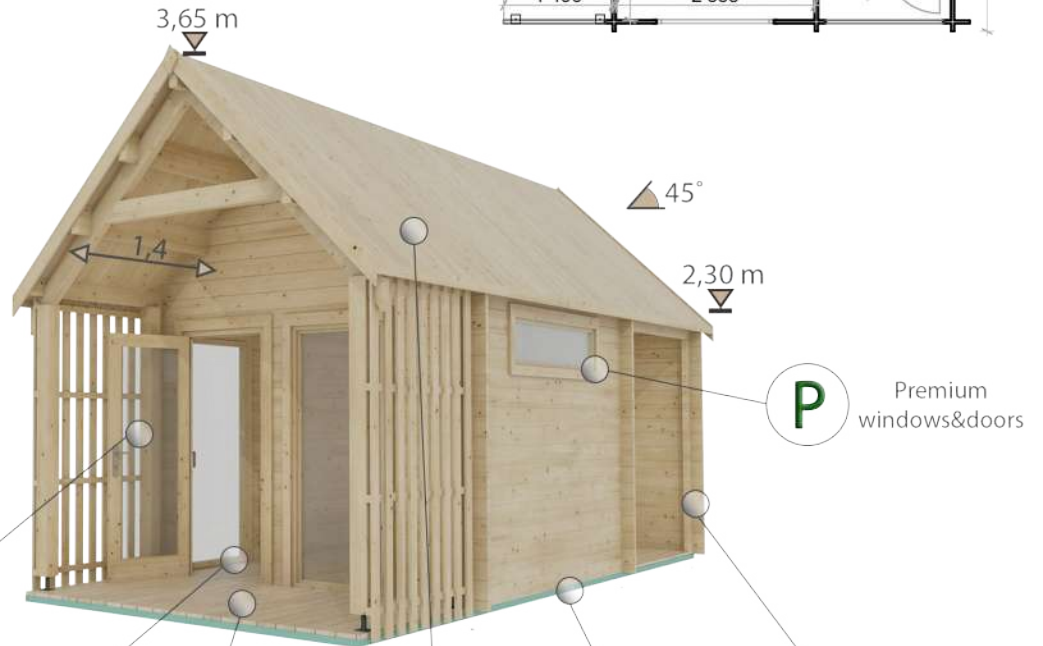

Project specification:

External measures: 3x6 m
 Base footprint: 2,8x5,8 m
 Internal house area: 10,2 m²
 Terrace area: 5,2 m²
 External wall area:
 Premium - 33,5 m²
 Economy - 32 m²
 Roof area: 25,8 m²

Windows and doors:

Door:
 Premium - 2 single 100% glass 1,98x0,85 m
 Economy - 2 single 100% glass 1,85x0,85 m
Window:
 Premium - 3 single 1,98x0,85 m, 1 single 1,98x0,5 m and 1 single 0,39x1,5 m
 Economy - 2 single 1,85x0,85 m, 1 single 1,85x0,5 m and 1 single 0,39x1,5 m
Threshold: covered with steel

Installation kit:

*See optional products pages 62-63

Padova A 6x4,5

Premium - Article No. S26251

Economy - Article No. S26785

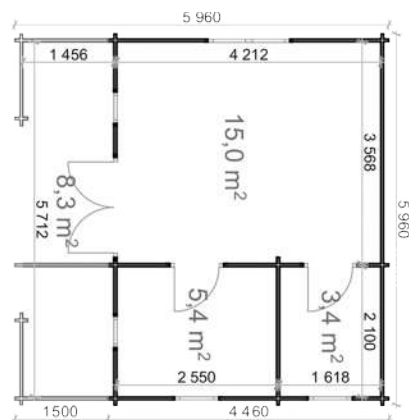

Garden house
gabled roof

30-57

Premium

Economy

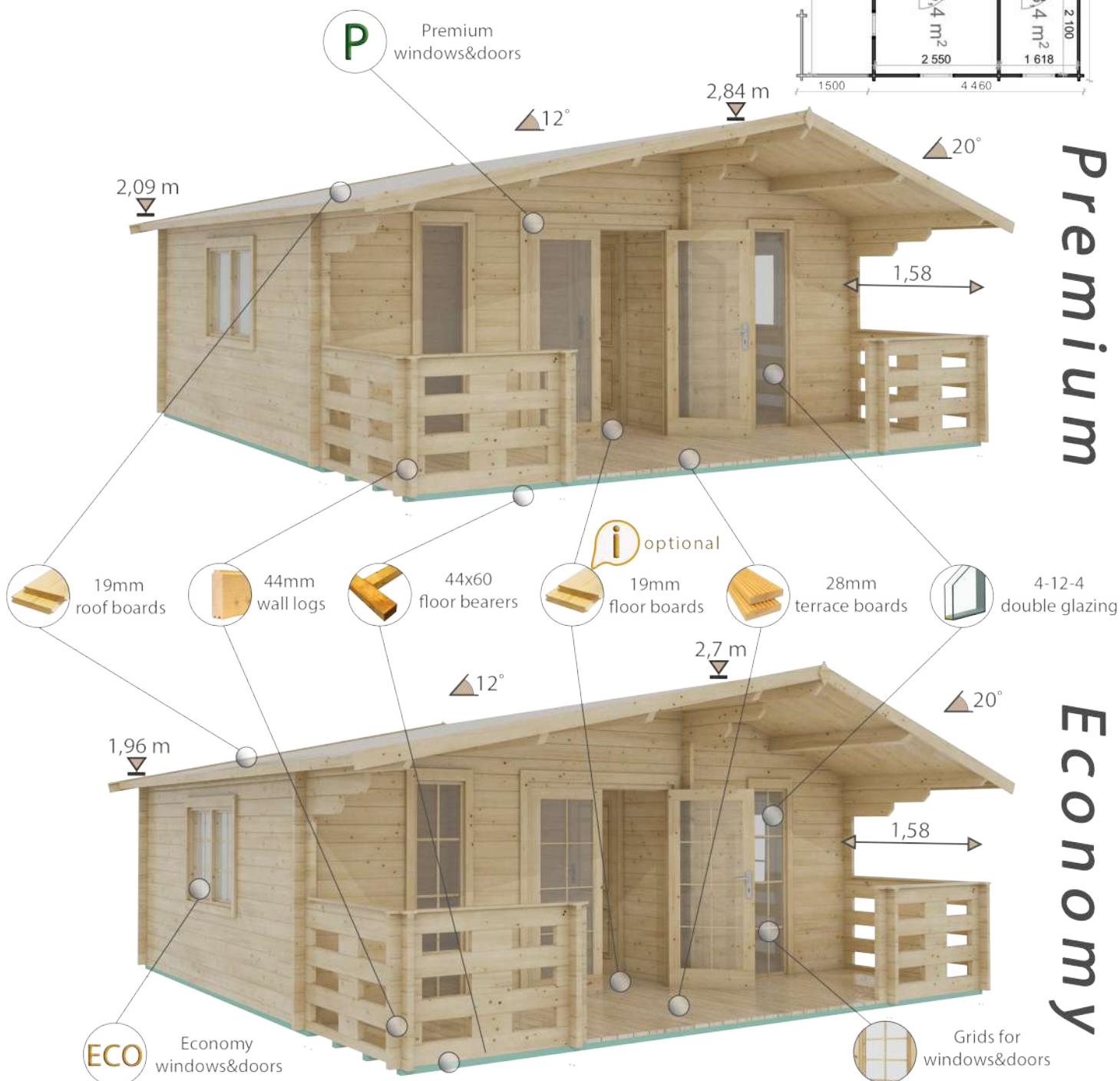

Project specification:

External measures: 5,96x4,46 m

Base footprint: 5,8x4,3 m

Internal house area: 23,8 m²

Terrace area: 8,3 m²

External wall area:

Premium - 43,3 m²

Economy - 40,5 m²

Roof area: 38,9 m²

Threshold: covered with steel

Windows and doors:

Door:

Premium - 1 double 100% glass 1,98x1,6 m and 2 single full wood 1,98x0,85 m

Economy - 1 double 100% glass 1,85x1,6 m and 2 single full wood 1,85x0,85 m

Window:

Premium - 2 single 1,98x0,5 m, 2 single 0,92x0,7 m and 1 double 0,92x1,3 m

Economy - 2 single 1,85x0,5 m, 2 single 0,92x0,7 m and 1 double 0,92x1,3 m

Installation kit:

Storm braces:

*See optional products pages 62-63

Padova B 6x6,5

Premium - Article No. S26252

Economy - Article No. S26788

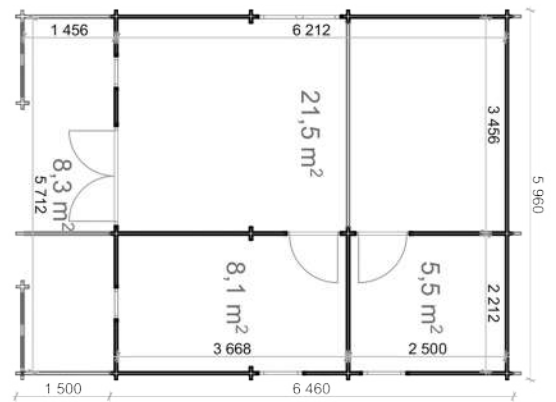

Garden house
gabled roof

Premium

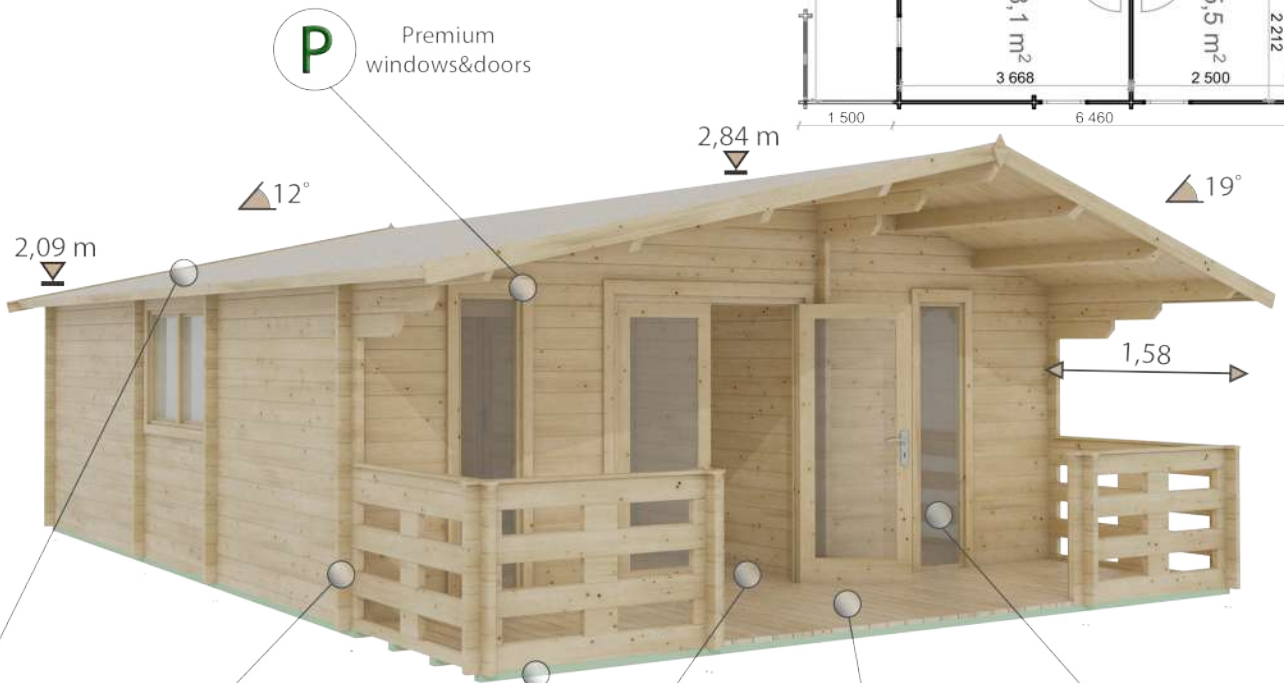

- 19mm roof boards
- 44mm wall logs
- 44x60 floor bearers
- optional 19mm floor boards
- 28mm terrace boards
- 4-12-4 double glazing

Economy

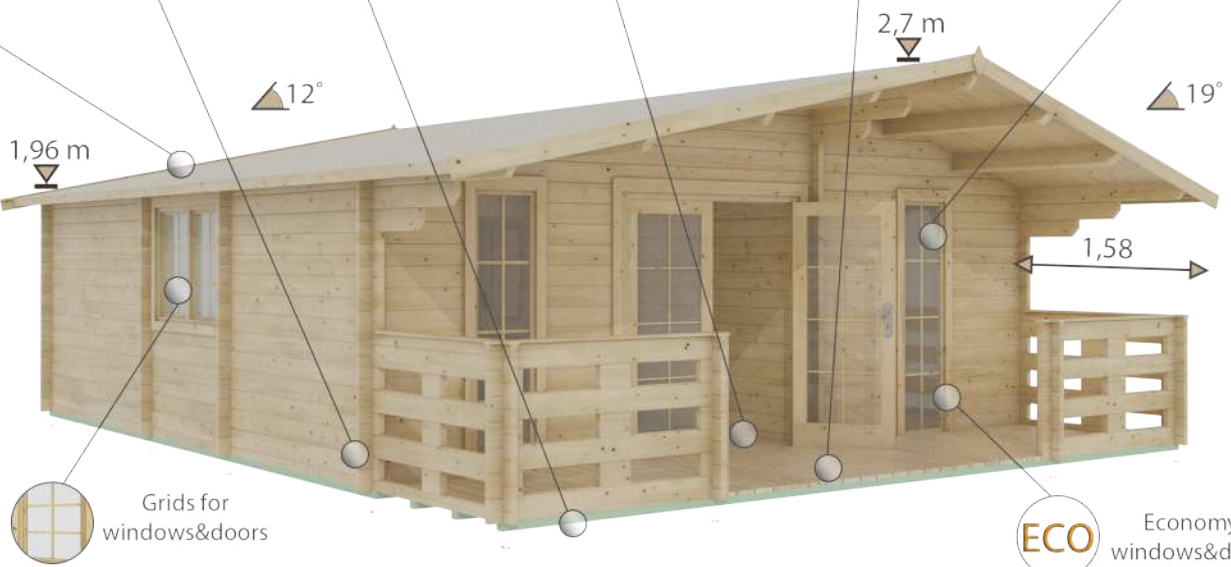

Grids for windows&doors

ECO Economy windows&doors

Project specification:

External measures: 5,96x6,46 m
Base footprint: 5,8x6,3 m
Internal house area: 35,1 m²
Terrace area: 8,3 m²
External wall area:
Premium - 51,3 m²
Economy - 47,9 m²
Roof area: 53 m²

Threshold: covered with steel

Windows and doors:

Door:

Premium - 1 double 100% glass 1,98x1,6 m and 2 single full wood 1,98x0,85 m
Economy - 1 double 100% glass 1,85x1,6 m and 2 single full wood 1,85x0,85 m

Window:

Premium - 2 single 1,98x0,5 m, 2 single 0,92x0,7 m and 1 double 0,92x1,3 m
Economy - 2 single 1,85x0,5 m, 2 single 0,92x0,7 m and 1 double 0,92x1,3 m

Installation kit:

Storm braces:

*See optional products pages 62-63

Roberto 5,6x4

Premium - Article No. S26789

Economy - Article No. S26790

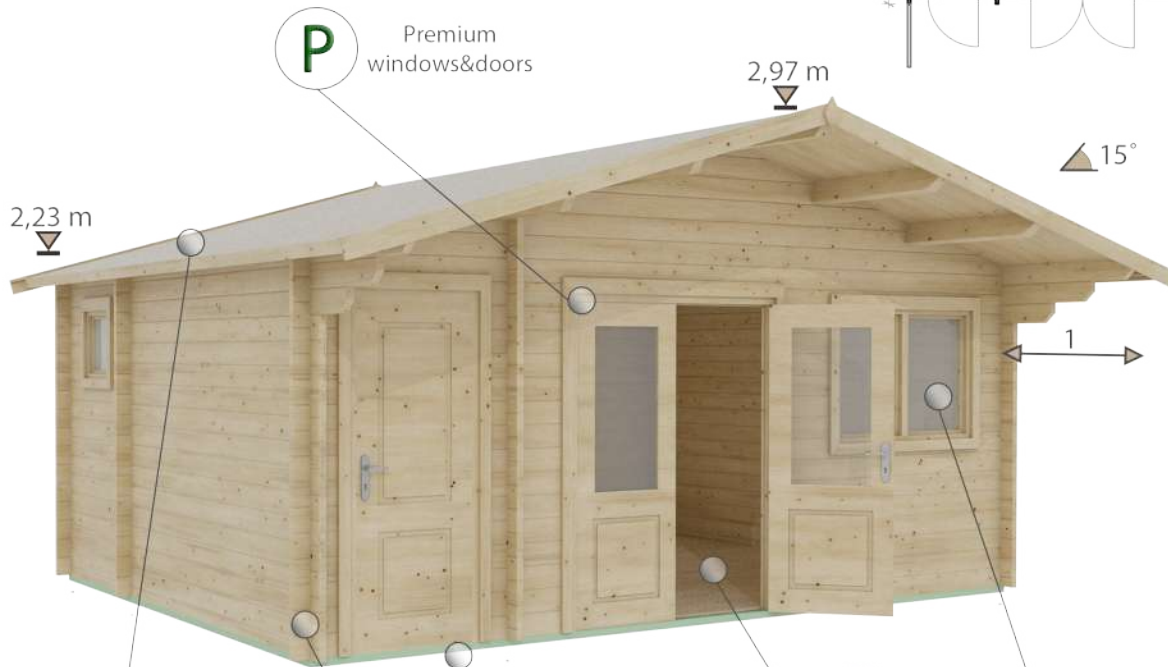
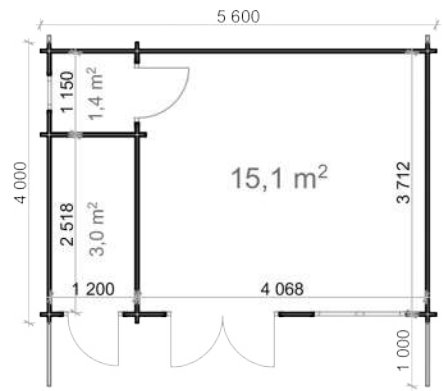

Premium

- 19mm roof boards
- 44mm wall logs
- 44x60 floor bearers
- 19mm floor boards
- 4-12-4 double glazing

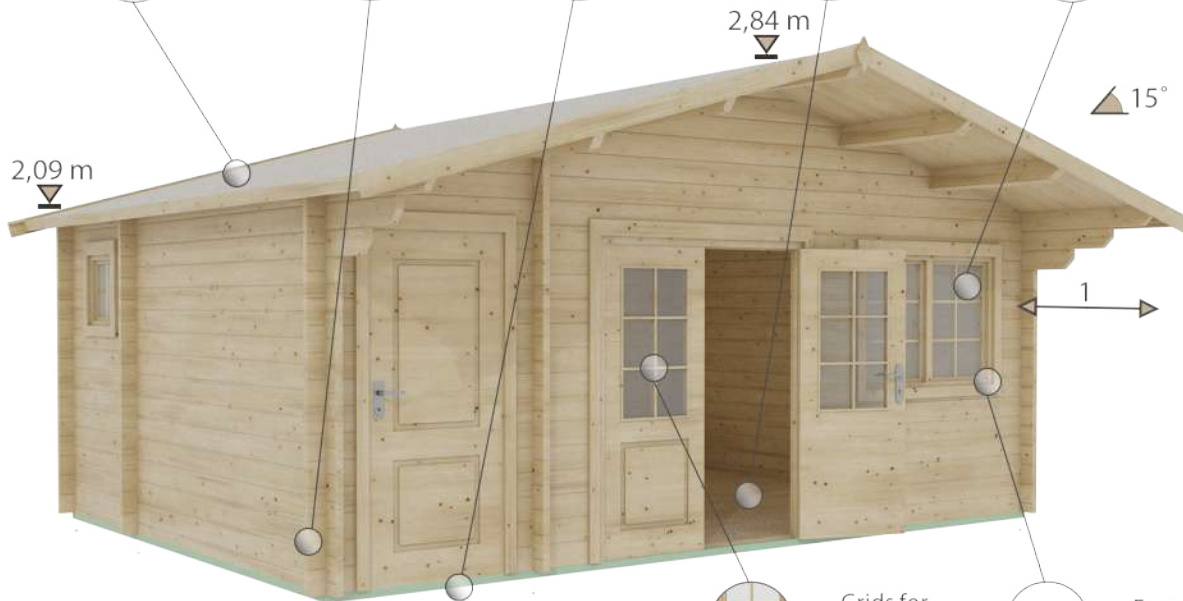

Economy

- Grids for windows&doors
- Economy windows&doors

Project specification:

External measures: 5,6x4 m
 Base footprint: 5,4x3,8 m
 Internal house area: 19,5 m²
 External wall area:
 Premium - 41,6 m²
 Economy - 39 m²
 Roof area: 30,6 m²

Windows and doors:

Door:
 Premium - 2 single full wood 1,98x0,85 m and 1 double 50% glass 1,98x1,6 m
 Economy - 2 single full wood 1,85x0,85 m and 1 double 50% glass 1,85x1,6 m
Window: 1 double 0,92x1,3 m and 1 single 0,52x0,5 m
Threshold: covered with steel

Possible reverse montage:

Installation kit:

Storm braces:

*See optional products pages 62-63

Scandi 3,7x6,9

Article No. S26284

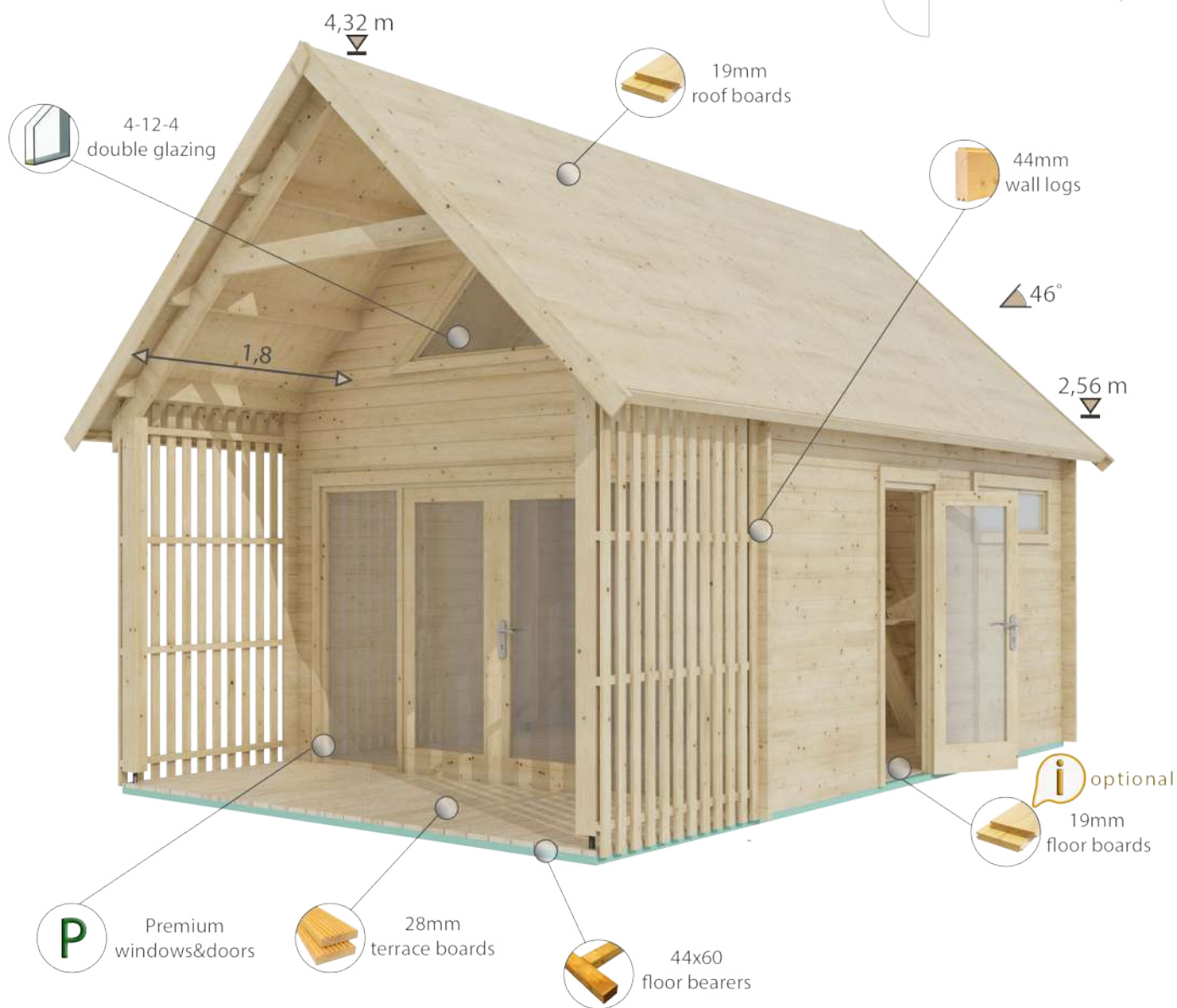
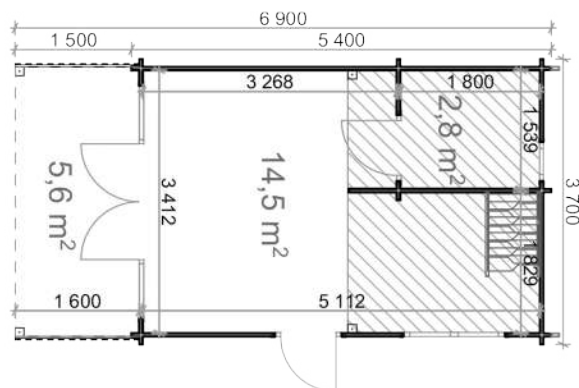

Project specification:

External measures: 3,7x5,9 m

Base footprint: 3,5x6,8 m

Internal house area:

Ground floor - 17,3 m²

Attic floor - 7,6 m²

Terrace area: 5,6 m²

External wall area: 44 m²

Roof area: 39,7 m²

Windows and doors:

Door: 1 quadruple 100% glass 1,98x3 m, 1 single 100% glass 1,98x0,85 m and 1 single full wood 1,98x0,85 m

Window: 1 single 0,52x0,5 m, 1 single 0,39x1,5 m and 2 trapezoid 0,8x1,5 m

Threshold: covered with steel

Attic floor:

Stair (space saver):

Installation kit:

*See optional products pages 62-63

Suzy 3,2x6

Premium - Article No. S26261

Economy - Article No. S26941

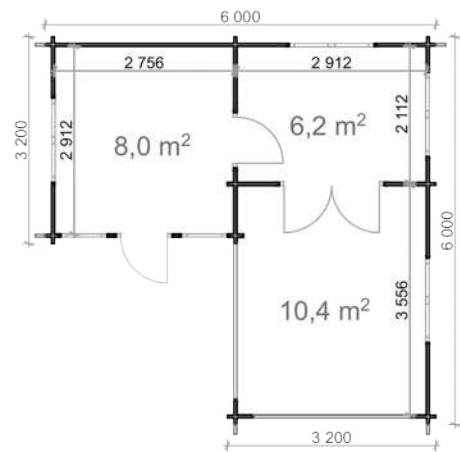

Premium

Economy

Garden house
gabled roof

30-57

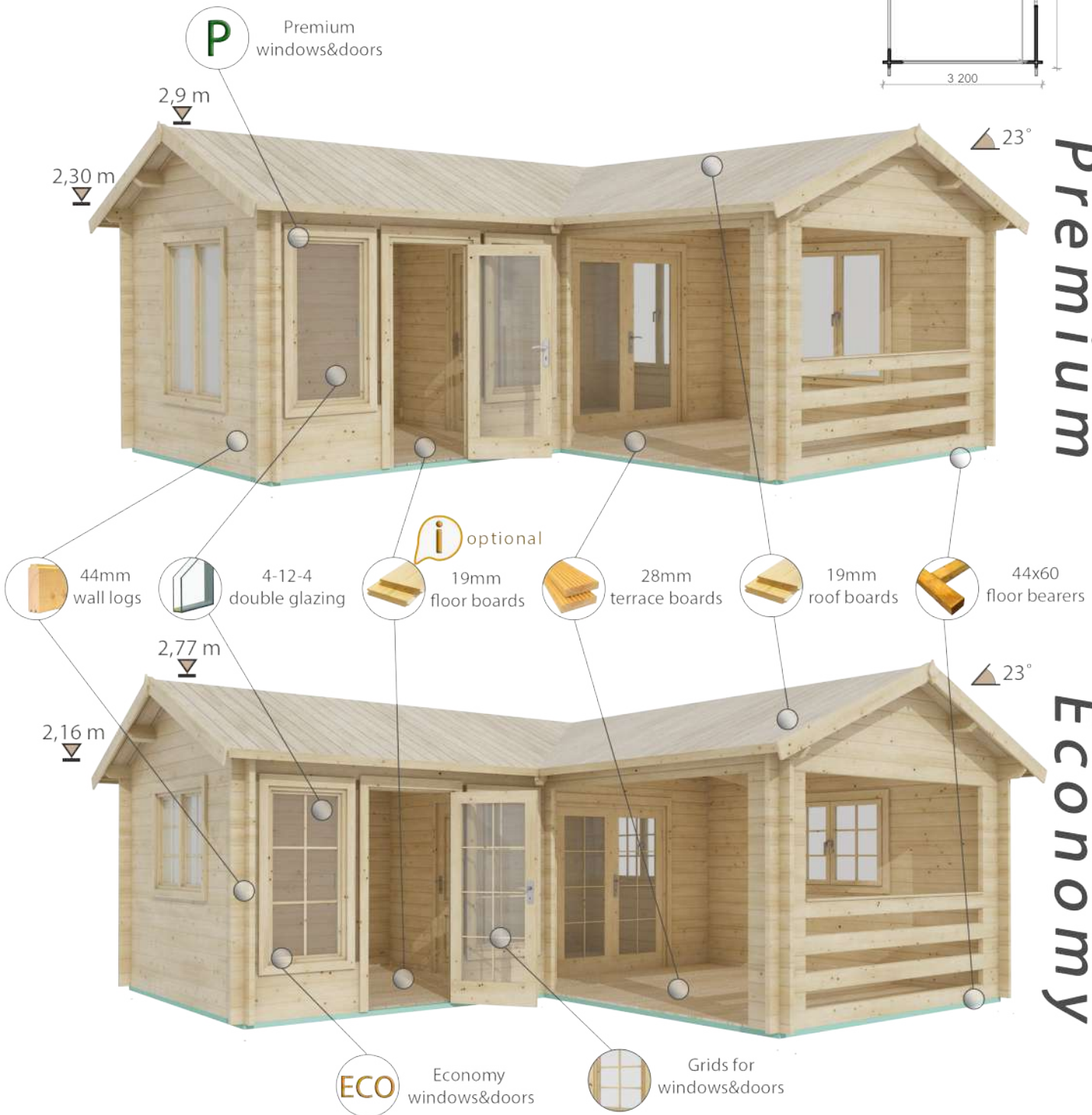

Project specification:

External measures: 3,2x6 m

Base footprint: 3x5,8 m

Internal house area: 14,2 m²

Terrace area: 10,4 m²

External wall area:

Premium - 38,5 m²

Economy - 34,5 m²

Roof area: 34,5 m²

Windows and doors:

Door:

Premium - 1 single full wood 1,98x0,85 m,
1 single 100% glass 1,98x0,85 m and 1
double 100% glass 1,98x1,6 m

Economy - 1 single full wood 1,85x0,85 m,
1 single 100% glass 1,85x0,85 m and 1
double 100% glass 1,85x1,6 m

Window: 2 single 143x70 m
and 4 double 1,43x1,3 m

Threshold: covered with steel

Installation kit:

*See optional products pages 62-63

Torino 4,5x6

*44mm and 68mm options are available

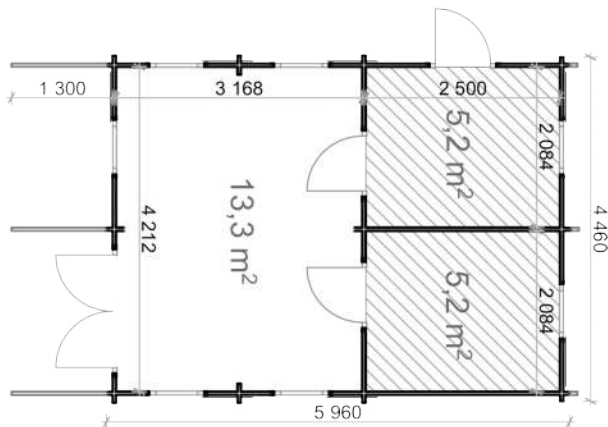

44mm

Premium - Article No. S26262

Economy - Article No. S26957

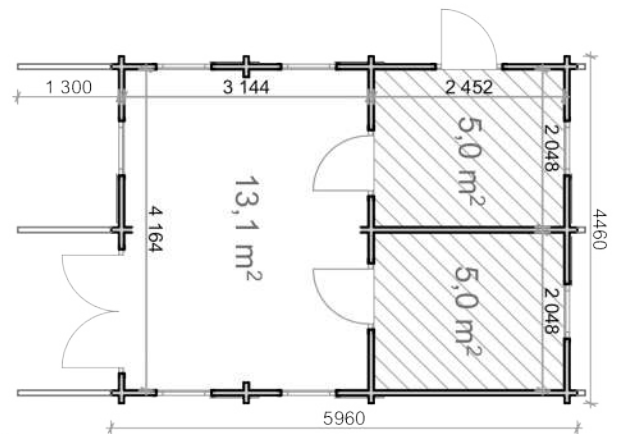

68mm

Article No. S26263



Project specification:

External measures: 4,46x5,96 m

Base footprint: 4,3x5,8 m

Internal house area:

Ground floor - 23,7 m²

Attic floor - 10,4 m²

External wall area:

Premium - 50 m²

Economy - 47 m²

Roof area: 42,9 m²

Windows and doors:

Door:

Premium - 2 single full wood 1,98x0,85 m,
1 single 50% glass 1,98x0,85 m and 1
double 50% glass 1,98x1,6 m

Premium

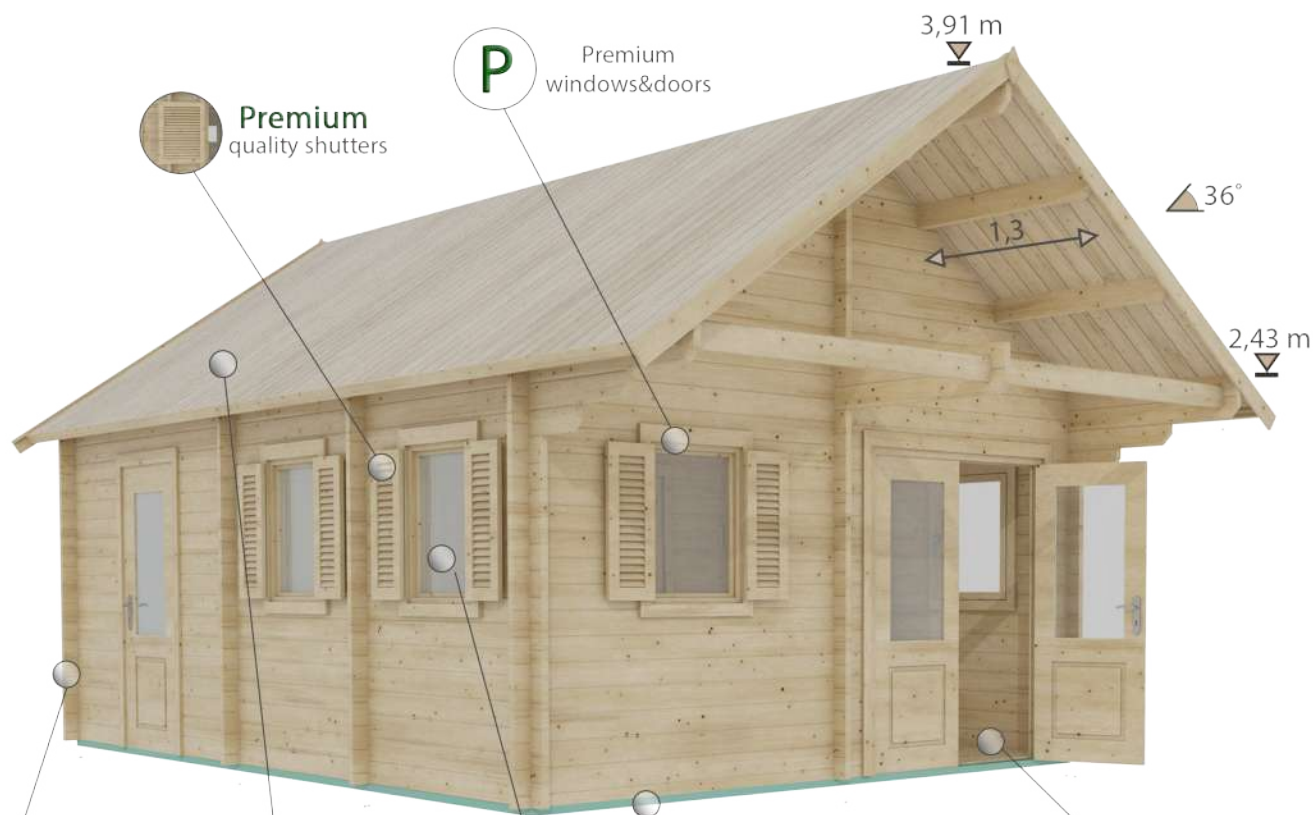

P Premium windows&doors

Premium quality shutters

36°

1,3

2,43 m

3,91 m

44mm wall logs
i 68mm version available

19mm roof boards

4-12-4 double glazing

i 68mm version has 68x60 floor bearers instead of 44x60
44x60 floor bearers

i optional 19mm floor boards

i 68mm version has 28mm floor boards instead of 19mm

3,78 m

ECO quality shutters

1,3

36°

2,30 m

Economy

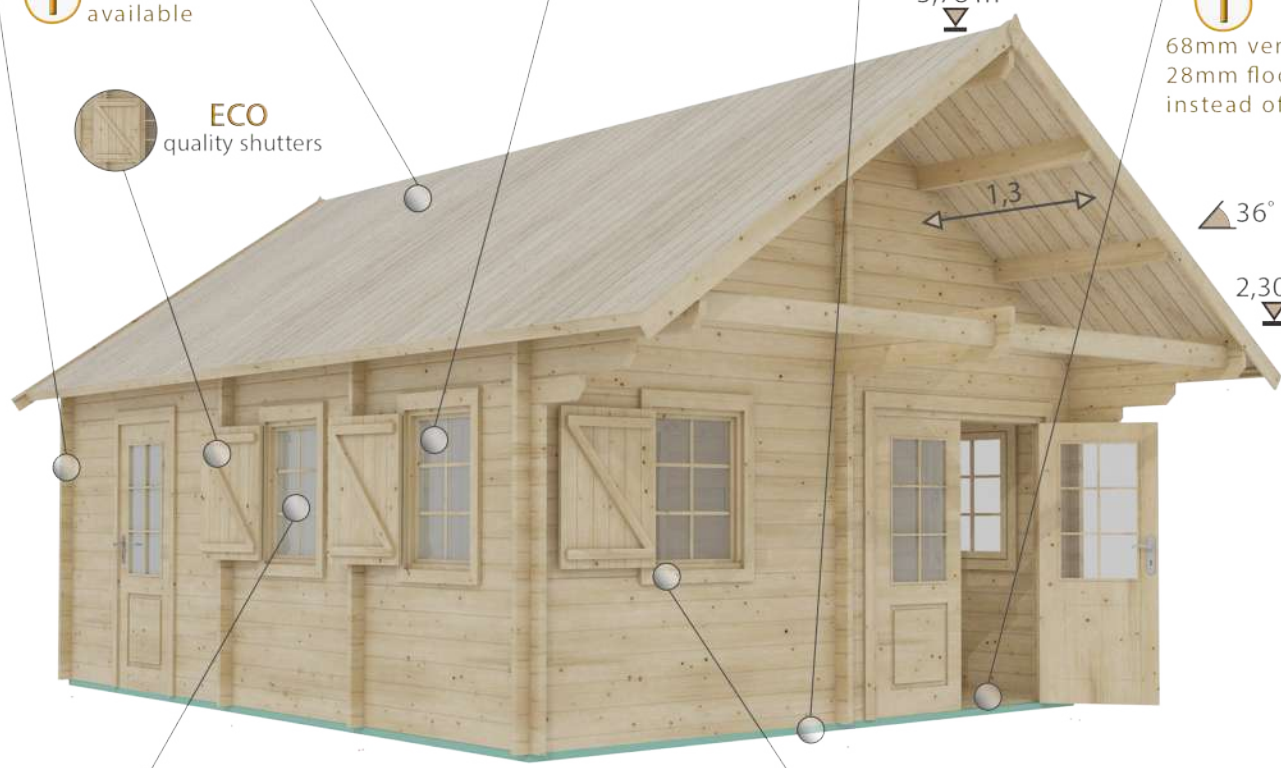

Grids for windows&doors

ECO Economy windows&doors

Economy - 2 single full wood 1,85x0,85 m,
1single 50% glass 1,85x0,85 m and 1
double 50% glass 1,85x1,6 m
Window: 7 single 0,92x0,7 m
Threshold: covered with steel

- Installation kit:**
Attic floor:
Ladder floor:
Shutters kit:

*See optional products pages 62-63

Trento 6x5

Premium - Article No. S26264

Economy - Article No. S26958

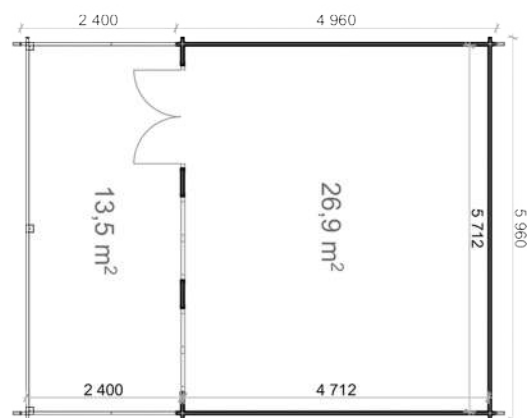

Premium

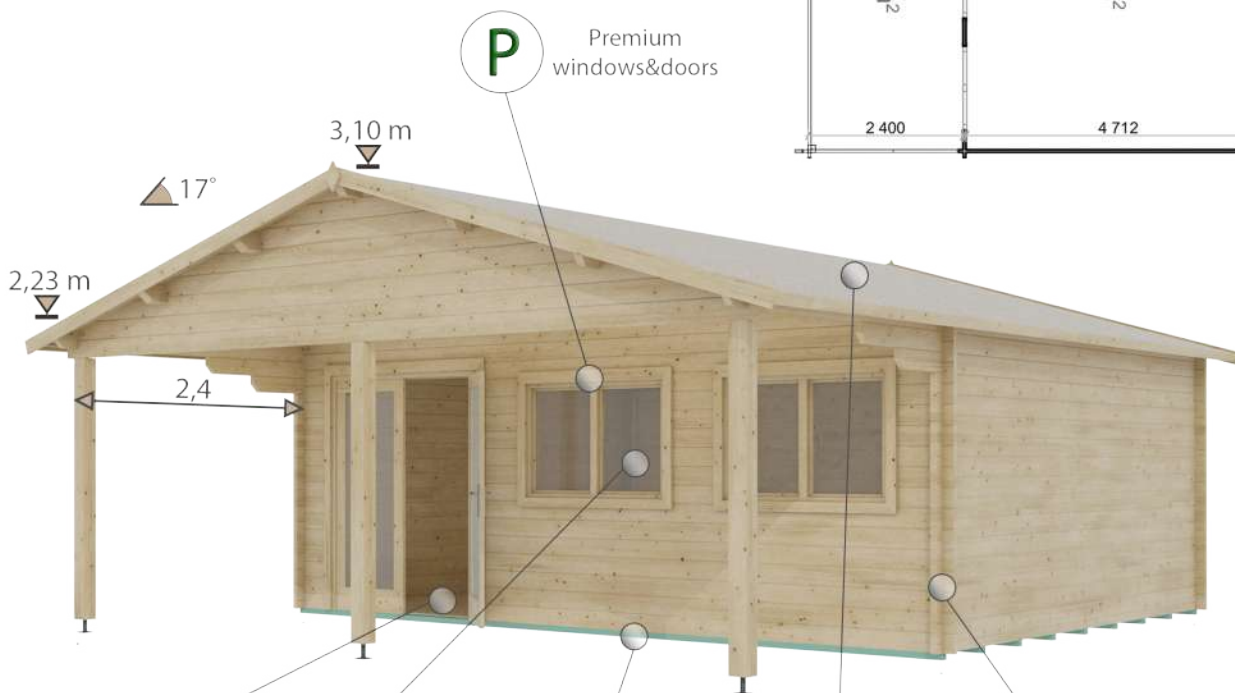

optional

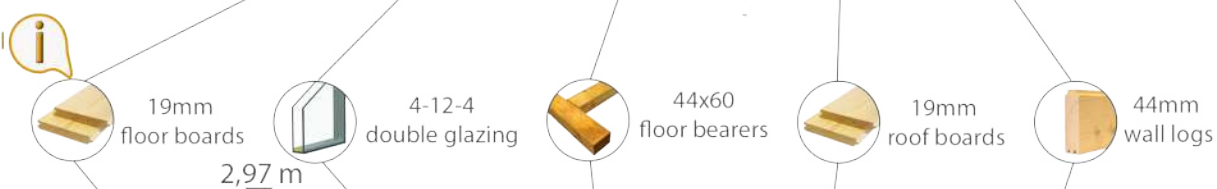

Economy

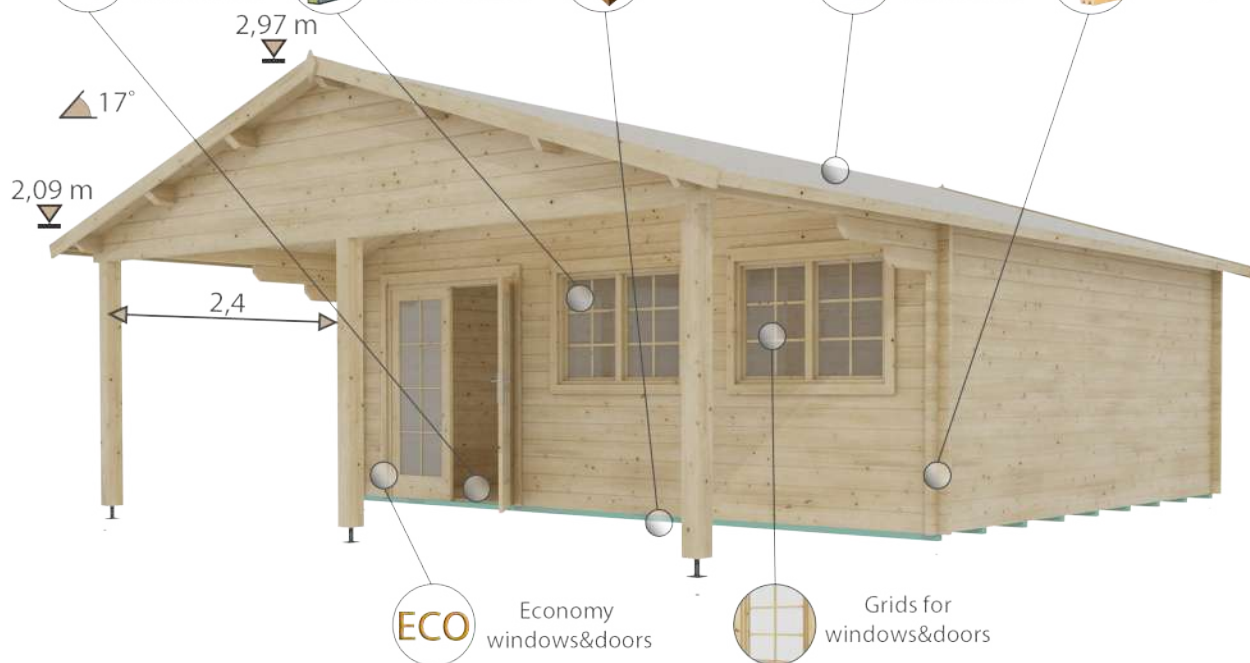

Project specification:

External measures: 5,96x4,96 m

Base footprint: 5,8x4,8 m

Internal house area: 26,9 m²

Terrace: 13,5 m²

External wall area:

Premium - 50 m²

Economy - 47 m²

Roof area: 49,4 m²

Windows and doors:

Door:

Premium - 1 double 100% glass 1,98x1,6 m

Economy - 1 double 100% glass 1,85x1,6 m

Window: 2 double 0,92x1,3 m

Threshold: covered with steel

Possible reverse montage:

Installation kit:

Storm braces:

*See optional products pages 62-63

Eric 3,3x7,36

Premium - Article No. S26353

Economy - Article No. S27447

 Economy version available 28mm
*see page 21th

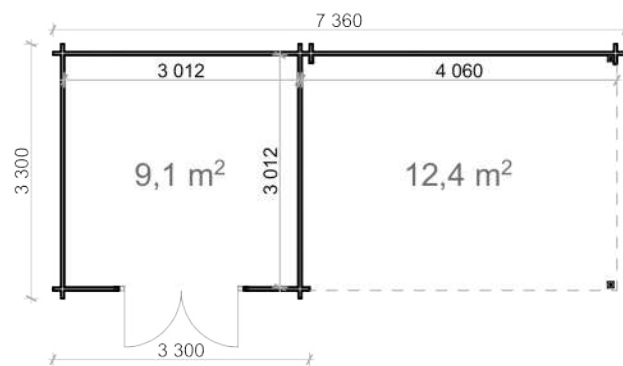

Garden house
flat roof
58-61



Premium



Economy



Project specification:

External measures: 3,3x7,36 m
Base footprint: 3,1x7,16 m
Internal house area: 9,1 m²
Terrace: 12,4 m²
External wall area:
Premium - 35,8 m²
Economy - 33,5 m²
Roof area: 24,7 m²

Windows and doors:

Door:
Premium - 1 double 100% glass 1,98x1,6 m
Economy - 1 double 100% glass 1,85x1,6 m
Threshold: covered with steel

Total height <2,5 m:
Installation kit:
Storm braces:

*See optional products pages 62-63

Eric 3x2,5 no canopy

Premium - Article No. S27448

Economy - Article No. S26753

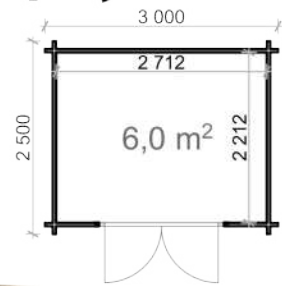

Garden house
flat roof

Premium



19mm
roof boards



44mm
wall logs

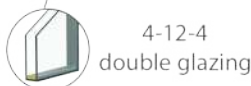

4-12-4
double glazing

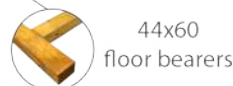

44x60
floor bearers

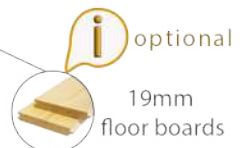

optional
19mm
floor boards

Economy

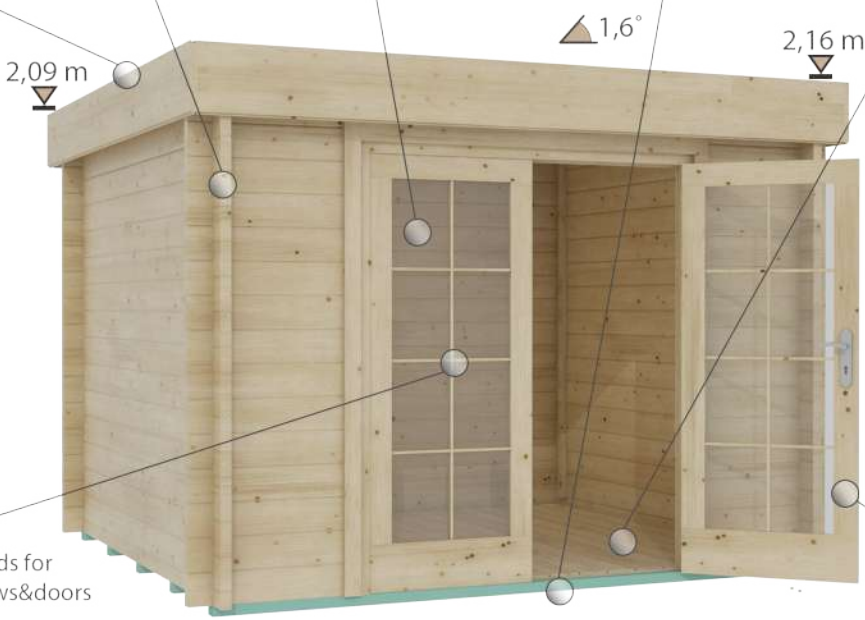

Grids for
windows&doors

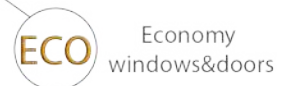

Economy
windows&doors

Project specification:

External measures: 3x2,5 m

Base footprint: 2,8x2,3 m

Internal house area: 6 m²

External wall area:

Premium - 22,1 m²

Economy - 20,6 m²

Roof area: 7,8 m²

Windows and doors:

Door:

Premium - 1 double 100% glass 1,98x1,6 m

Economy - 1 double 100% glass 1,85x1,6 m

Threshold: covered with steel

Total height <2,5 m:

Possible reverse montage:

Installation kit:

Storm braces:

*See optional products pages 62-63

Ottawa 6x4,5

Premium - Article No. S26275

Economy - Article No. S26938

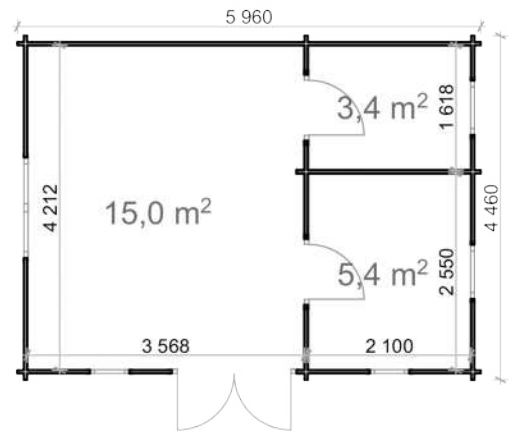

Premium

Economy

Garden house
flat roof
58-61

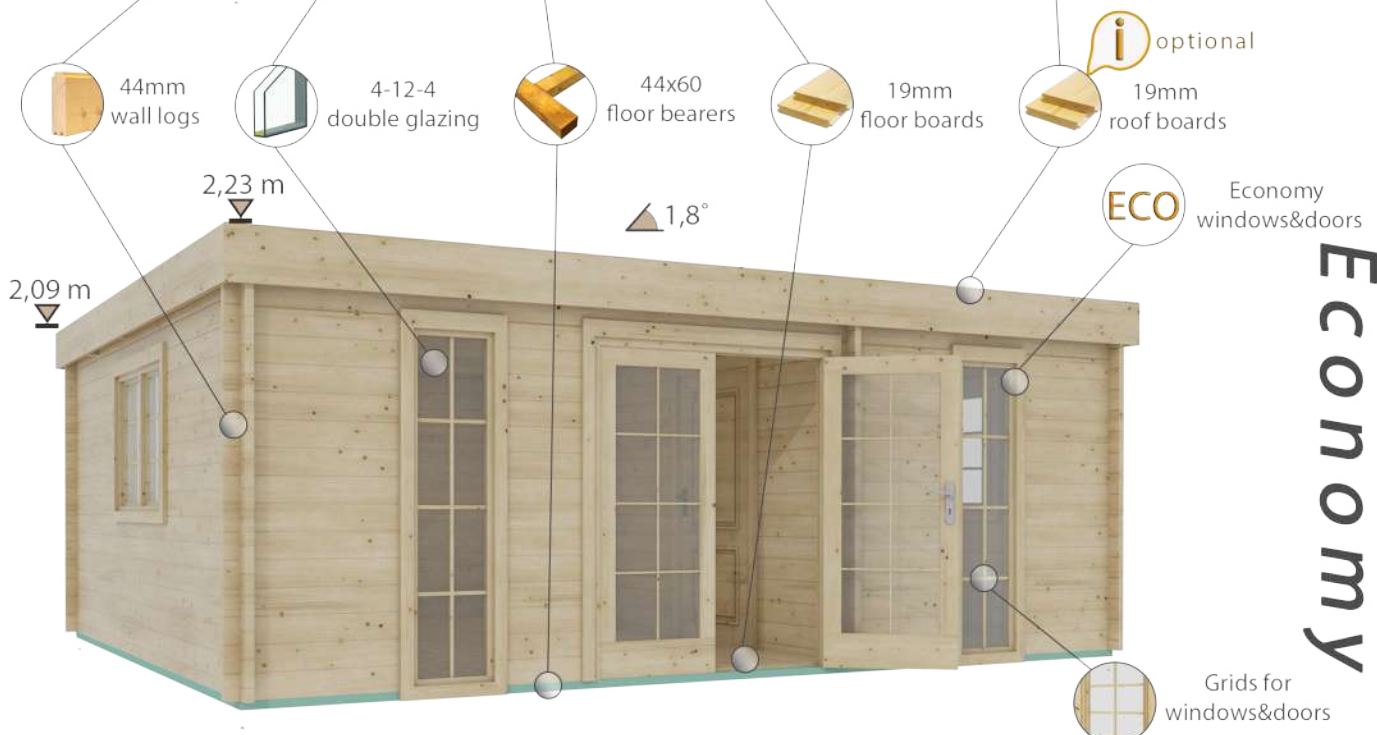
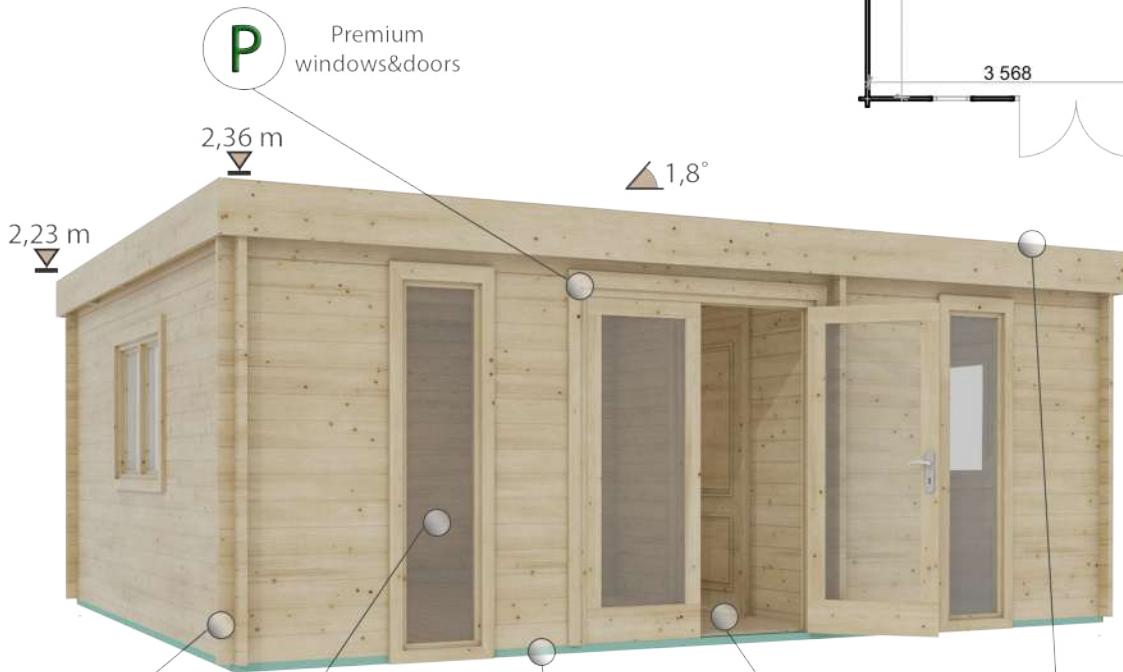

Project specification:

External measures: 5,96x4,46 m
 Base footprint: 5,8x4,3 m
 Internal house area: 23,8 m²
 External wall area:
 Premium - 40,9 m²
 Economy - 38,1 m²
 Roof area: 27,3 m²

Threshold: covered with steel

Windows and doors:

Door:
 Premium - 1 double 100% glass 1,98x1,6 m and 2 single full wood 1,98x0,85 m
 Economy - 1 double 100% glass 1,85x1,6 m and 2 single full wood 1,85x0,85 m
Window:
 Premium - 2 single 1,98x0,5 m, 2 single 0,92x0,7 m and 1 double 0,92x1,3 m
 Economy - 2 single 1,85x0,5 m, 2 single 0,92x0,7 m and 1 double 0,92x1,3 m

- Total height <2,5 m:
- Possible reverse montage:
- Installation kit:
- Storm braces:

*See optional products pages 62-63

Rico 4,04x7,8

Premium - Article No. S26272

Economy - Article No. S26939

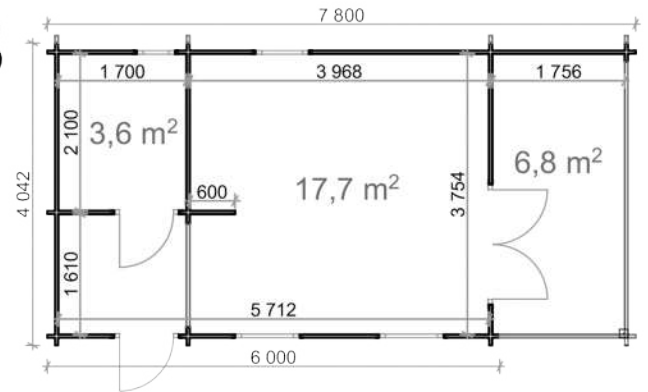

Premium

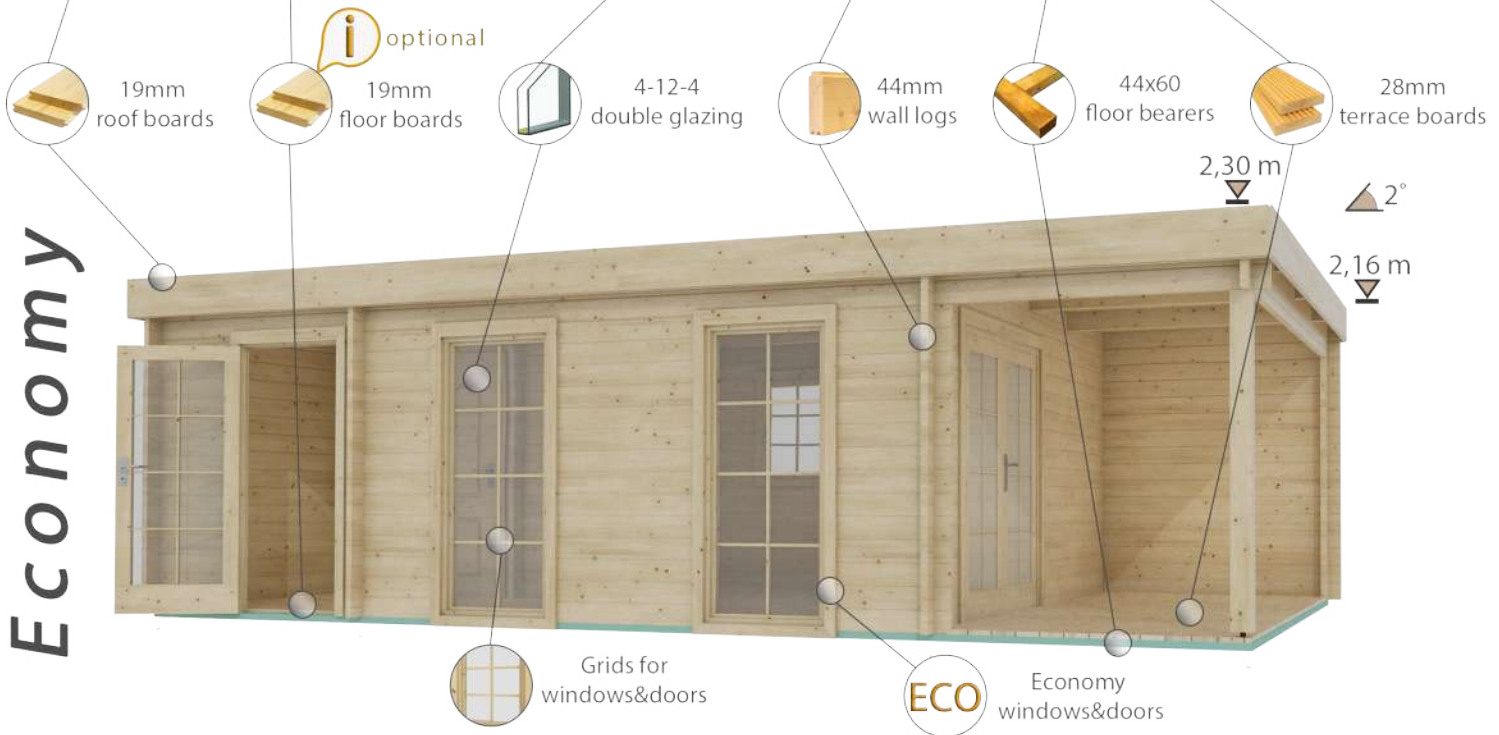

Project specification:
 External measures: 4,04x7,8 m
 Base footprint: 3,84x7,6 m
 Internal house area: 21,3 m²
 Terrace: 6,8 m²
 External wall area:
 Premium - 39,2 m²
 Economy - 36,5 m²
 Roof area: 32,3 m²

Windows and doors:
Door:
 Premium - 1 double 100% glass 1,98x1,6 m, 1 single full wood 1,98x0,85 m and 1 single 100% glass 1,98x0,85 m
 Economy - 1 double 100% glass 1,85x1,6 m, 1 single full wood 1,85x0,85 m and 1 single 100% glass 1,85x0,85 m

Threshold: covered with steel

Window:
 Premium - 1 single 0,52x0,5m, 1 single 0,92x0,7 m and 2 single 1,98x0,85 m
 Economy - 1 single 0,52x0,5m, 1 single 0,92x0,7 m and 2 single 1,85x0,85 m

Total height <2,5 m:
Installation kit:
Storm braces:

*See optional products pages 62-63

Optional products

For garden house

Wall	Name	Article No. Premium/Economy	Dipping (pine colour)	Bitumen roof tiles	Underlayer	EPDM roof cover	Metal roof cover	Rain gutters	Terrace	Quality of windows and doors	Insulation
44	Deko 5x3	S26206/S27438	●	● 24m ²	● 21m'	●	●	●	● 5x1,5		
44	Eko 5x5,7	S26210/S27443	●	● 39m ²	● 39m'	●	●	●	● 5x1,5	P+	Walls/roof/floor
44	Elise 3x5,9	S26352/S27445	●	● 27m ²	● 24m'	●	●	●			
44	Erna 2,5x3,4	S27449/S27450	●	● 12m ²	● 12m'	●	●	●			
44	Erna 2,5x4,5	S26216/S26922	●	● 18m ²	● 14m'	●	●	●			
44	Hakan A 6x5,2	S26228/S26742	●	● 39m ²	● 40m'	●	●	●		P+	Walls/roof/floor
44	Hakan B 7x7,19	S24190/S26743	●	● 60m ²	● 61m'	●	●	●		P+	Walls/roof/floor
44	Helmand 3x9	S26196/S26935	●	● 36m ²	● 36m'	●	●	●		P+	Walls/roof/floor
44	Linus 4x3	S26755/S26757	●	● 21m ²	● 20m'	●	●	●	● 4x1,5		
44	Linus 4x4	S26233/S26760	●	● 24m ²	● 25m'	●	●	●	● 4x1,5		
44	Linus 4x5	S26234/S26754	●	● 30m ²	● 30m'	●	●	●	● 4x1,5		
44	Linus 5x4	S26235/S26764	●	● 30m ²	● 30m'	●	●	●	● 5x1,5		
44	Linus 5x5	S26236/S26763	●	● 36m ²	● 37m'	●	●	●	● 5x1,5		
44	Linus 5x6	S26758/S26759	●	● 42m ²	● 43m'	●	●	●	● 5x1,5		
44	Linus 6x4	S27466/S27465	●	● 36m ²	● 36m'	●	●	●	● 6x1,5		
44	Linus 6x5	S27463/S27464	●	● 42m ²	● 43m'	●	●	●	● 6x1,5		
44	Linus 6x6	S26237/S26766	●	● 48m ²	● 51m'	●	●	●	● 6x1,5		
44	Linus 5x4 WC	S26771/S28440	●	● 30m ²	● 30m'	●	●	●	● 5x1,5		
44	Linus 5x5 WC	S26773/S28442	●	● 36m ²	● 37m'	●	●	●	● 5x1,5		
44	Linus 6x5 WC	S26774/S28441	●	● 42m ²	● 43m'	●	●	●	● 6x1,5		
44	Linus 6x6 WC	S26238/S26767	●	● 48m ²	● 51m'	●	●	●	● 6x1,5		
44	Milano 3,8x3,8	S26781/S26782	●	● 27m ²	● 25m'	●	●	●			Walls/roof/floor
44	Murray 4x6	S26936/S26248	●	● 33m ²	● 31m'	●	●	●	● 6x1,5	P+	Walls/roof/floor
44	Oslo 3x6	S26270/S26937	●	● 33m ²	● 29m'	●	●	●		P+	Walls/roof/floor
44	Padova A 6x4,5	S26251/S26785	●	● 42m ²	● 43m'	●	●	●		P+	Walls/roof/floor
44	Padova B 6x6,5	S26252/S26788	●	● 57m ²	● 59m'	●	●	●		P+	Walls/roof/floor
44	Roberto 5,6x4	S26789/S26790	●	● 33m ²	● 34m'	●	●	●			
44	Scandi 3,7x6,9	S26284	●	● 45m ²	● 44m'	●	●	●		P+	Walls/roof/floor
44	Suzy 3,2x6	S26261/S26941	●	● 42m ²	● 38m'	●	●	●		P+	Walls/roof/floor
44	Torino 4,5x6	S26262/S26957	●	● 48m ²	● 48m'	●	●	●	● 4,5x1,5	P+, HQ, PVC	Walls/roof/floor
68		S26263									
44	Trento 6x5	S26264/S26958	●	● 54m ²	● 55m'	●	●	●			

Optional products

For garden house

Wall	Name	Article No. Premium/Economy	Dipping (pine colour)	Bitumen roof tiles	Underlayer	EPDM roof cover	Metal roof cover	Rain gutters	Terrace	Quality of windows and doors	Insulation
4 4	Eric 3,3x7,36	S26353/S27447	●			● 26m ²		●			
4 4	Eric 3x2,5	S27448/S26753	●			● 9m ²		●			
4 4	Ottawa 6x4,5	S26275/S26938	●			● 29m ²		●	● 6x1,5	P+	Walls/roof/floor
4 4	Rico 4,04x7,8	S26272/S26939	●			● 34m ²		●		P+	Walls/roof/floor

Home office/ studio





Agoti 5x3
p. 66



Bergen 4,2x8
p. 66



Emily 4,04x7,08
p. 67



Lille 6x3,5
p. 67



Nuuk 5x3,84
p. 68



Oden 5x3,5
p. 68



Sydney 3,8x3,8
p. 69



Togo 3x3
p. 69



Wik 4,5x3,5
p. 70



Agoti 5x3

Article No. S26832

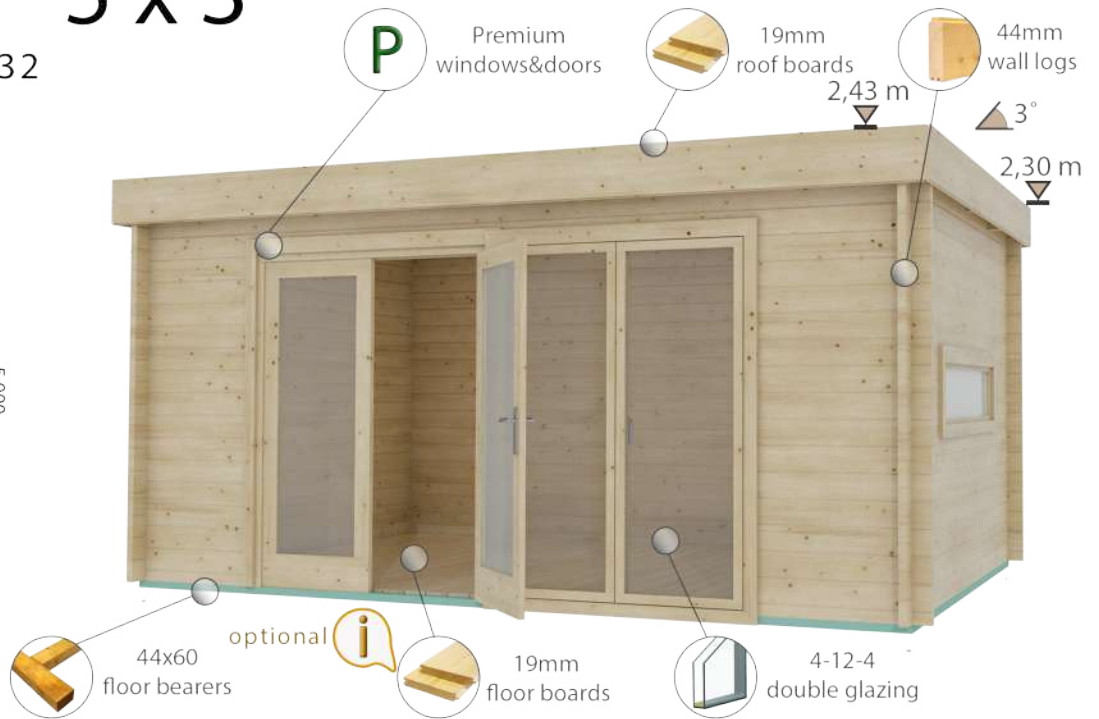
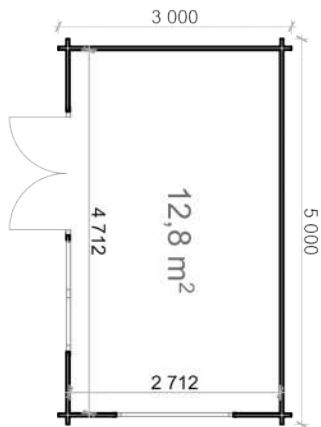

Project specification:
 External measures: 5x3 m
 Base footprint: 4,8x2,8 m
 Internal house area: 12,8 m²
 External wall area: 32 m²
 Roof area: 15 m²

Windows and doors:
 Door: 1 double 100% glass 1,98x1,6 m
 Window: 1 single 0,39x1,5 m and 1 double 1,98x1,5 m
 Threshold: covered with steel

Total height < 2,5 m:
 Possible reverse montage:
 Installation kit:
 Storm braces:

*See optional products page 71

Bergen 4,2x8

Article No. S26271

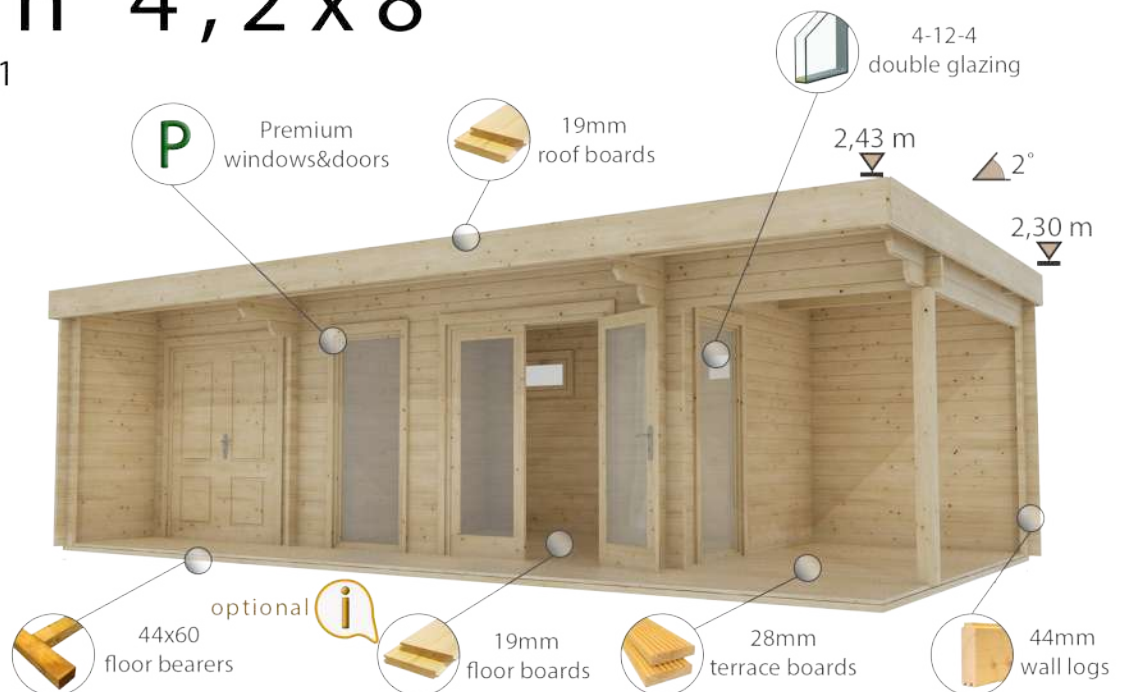
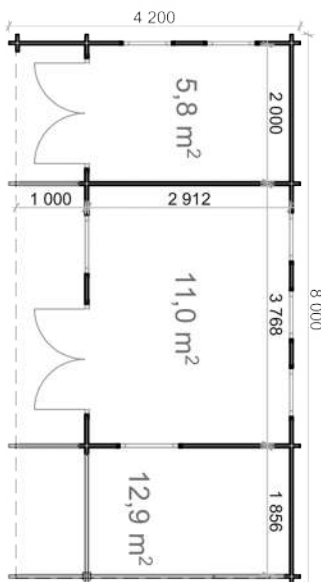

Project specification:
 External measures: 4,2x8 m
 Base footprint: 4x7,8 m
 Internal house area: 16,8 m²
 Terrace: 12,9 m²
 External wall area: 36 m²
 Roof area: 33,6 m²

Windows and doors:
 Door: 1 double 100% glass 1,98x1,6 m, 1 double full wood 1,98x1,6 m
 Window: 5 single 0,39x0,7 m and 2 single 1,98x0,85 m
 Threshold: covered with steel

Total height < 2,5 m:
 Installation kit:
 Storm braces:

*See optional products page 71

Emily 4,04x7,08

Article No. S26276

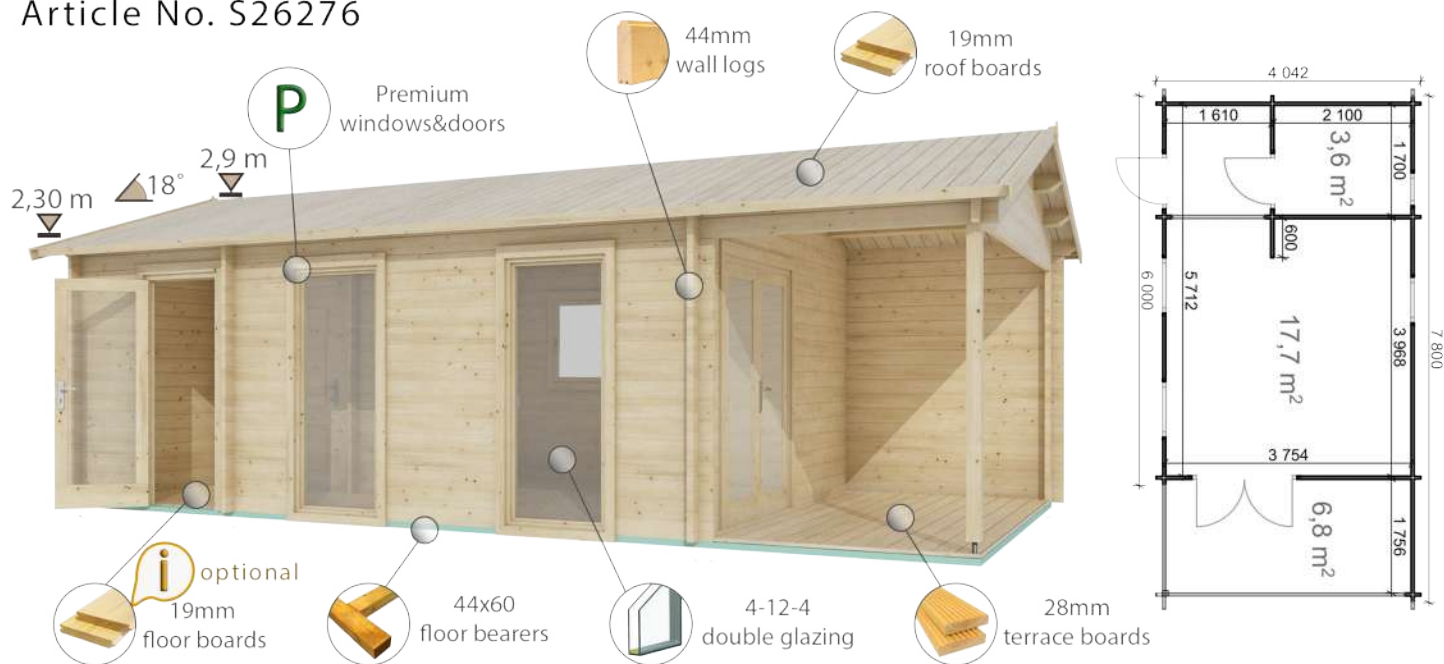

Project specification:

External measures: 4,04x7,8 m
 Base footprint: 3,84x7,6 m
 Internal house area: 21,3 m²
 Terrace: 6,8 m²
 External wall area: 41 m²
 Roof area: 36,2 m²

Windows and doors:

Door: 1 double 100% glass 1,98x1,6 m, 1 single 100% glass 1,98x0,85 m and 1 single full wood 1,98x0,85 m
 Window: 1 single 0,52x0,5 m, 1 single 0,92x0,7 m and 2 single 1,98x0,85 m
 Threshold: covered with steel

Total height < 2,5 m:

Installation kit:

Storm braces:

*See optional products page 71

Lille 6x3,5

Article No. S25470

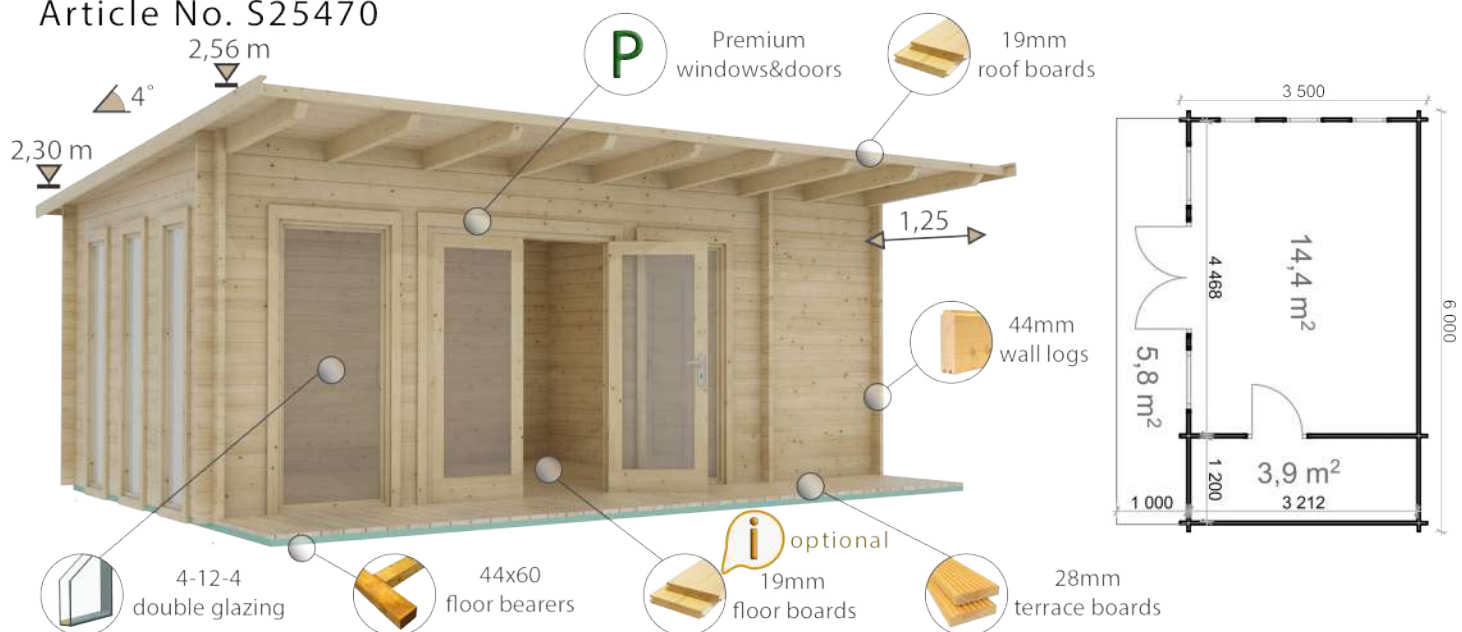

Project specification:

External measures: 6x3,5 m
 Base footprint: 5,8x3,3 m
 Internal house area: 18,3 m²
 Terrace: 5,8 m²
 External wall area: 37 m²
 Roof area: 30 m²

Windows and doors:

Door: 1 double 100% glass 1,98x1,6 m and 1 single full wood 1,98x0,85 m
 Window: 3 single 1,98x0,5 m and 2 single 1,98x0,85 m
 Threshold: covered with steel

Possible reverse montage:

Installation kit:

Storm braces:

*See optional products page 71

Nuuk 5x3,84

Article No. S26835

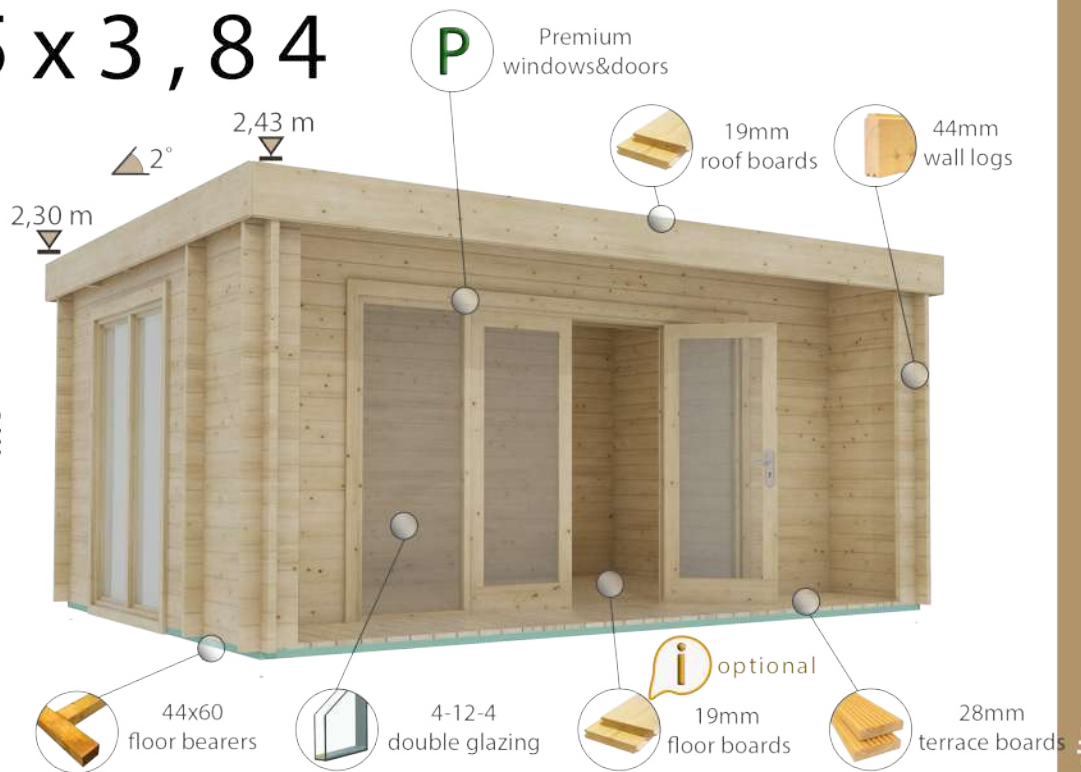
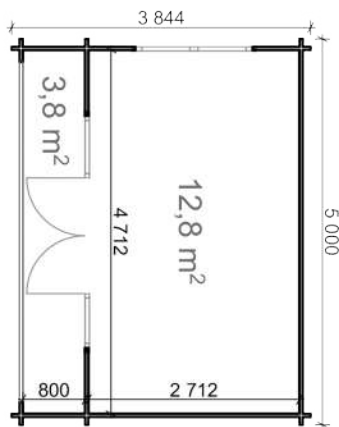

Project specification:
 External measures: 5x3,84 m
 Base footprint: 4,8x3,64 m
 Internal house area: 12,8 m²
 Terrace: 3,8 m²
 External wall area: 35 m²
 Roof area: 20 m²

Windows and doors:
 Door: 1 quadruple 100% glass
 1,98x3,0 m
 Window: 1 double 1,98x1,5 m
 Threshold: covered with steel

Total height < 2,5 m:
 Possible reverse montage:
 Installation kit:
 Storm braces:

*See optional products page 71

Oden 5x3,5

Article No. S26851

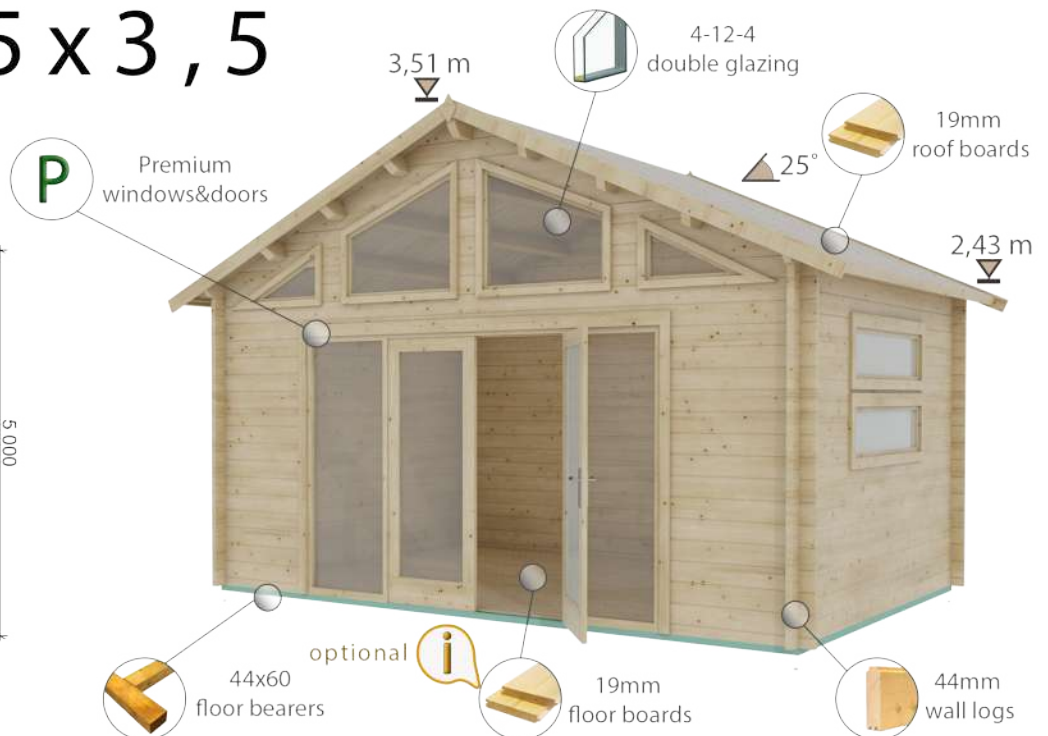
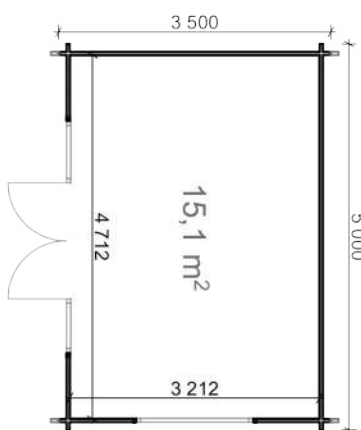

Project specification:
 External measures: 5x3,5 m
 Base footprint: 4,8x3,3 m
 Internal house area: 15,1 m²
 External wall area: 39 m²
 Roof area: 22 m²

Windows and doors:
 Door: 1 quadruple 100% glass
 1,98x3,0 m
 Window: 2 single 0,39x1,5 m, 2
 trapezoid 0,4x0,8 m and 2 trapezoid
 0,9x1 m
 Threshold: covered with steel

Possible reverse montage:
 Installation kit:
 Storm braces:

*See optional products page 71

Sydney 3,8x3,8

Article No. S26296

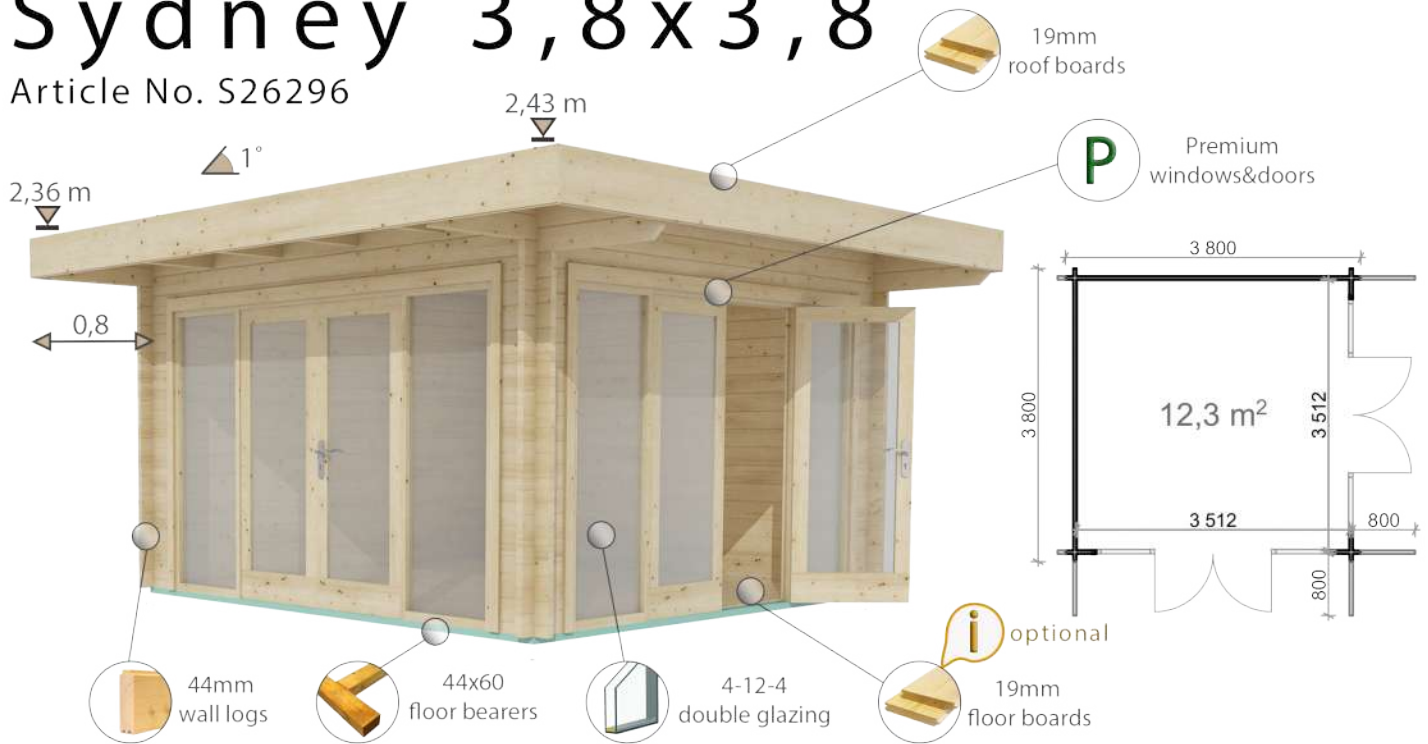

Project specification:

External measures: 3,8x3,8 m
 Base footprint: 3,6x3,6 m
 Internal house area: 12,3 m²
 External wall area: 26 m²
 Roof area: 20,3 m²

Windows and doors:

Door: 2 quadruple 100% glass
 1,98x3,0 m
 Threshold: covered with steel

Total height < 2,5 m:

Possible reverse montage:

Installation kit:

Storm braces:

*See optional products page 71

Togo 3x3

Article No. S26853

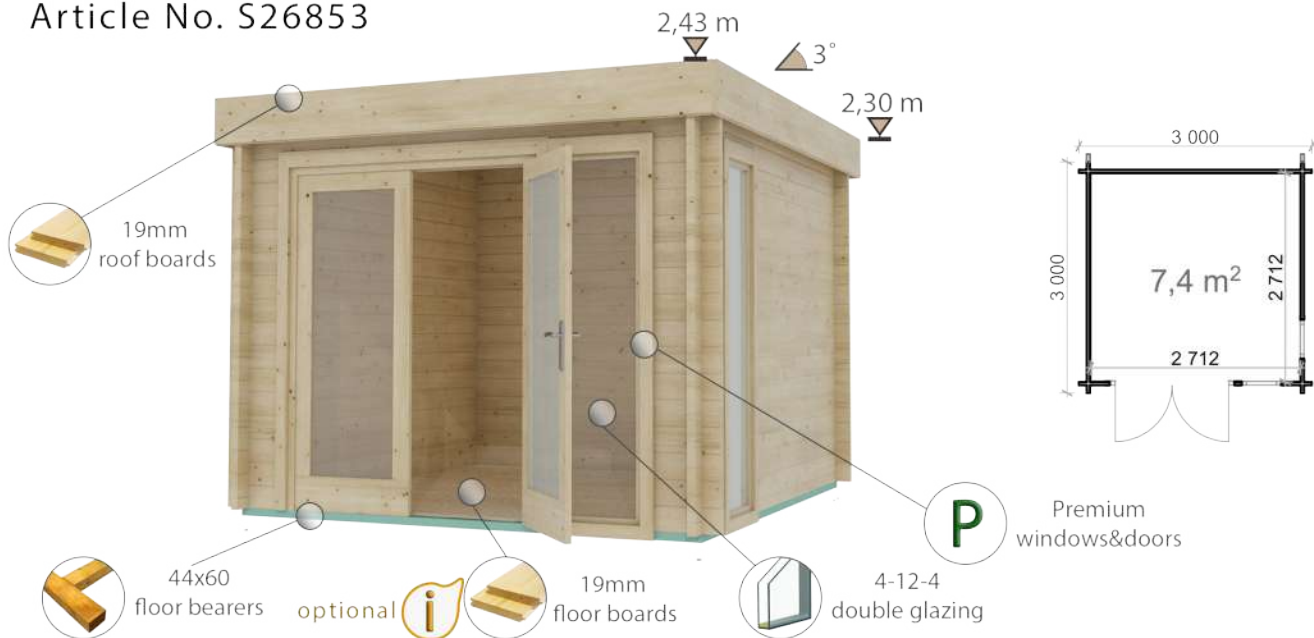

Project specification:

External measures: 3x3 m
 Base footprint: 2,8x2,8 m
 Internal house area: 7,4 m²
 External wall area: 24 m²
 Roof area: 9 m²

Windows and doors:

Door: 1 double 100% glass 1,98x1,6 m
 Window: 2 single 1,98x0,5 m
 Threshold: covered with steel

Total height < 2,5 m:

Possible reverse montage:

Installation kit:

Storm braces:

*See optional products page 71

Wik 4,5x3,5

Article No. S26857

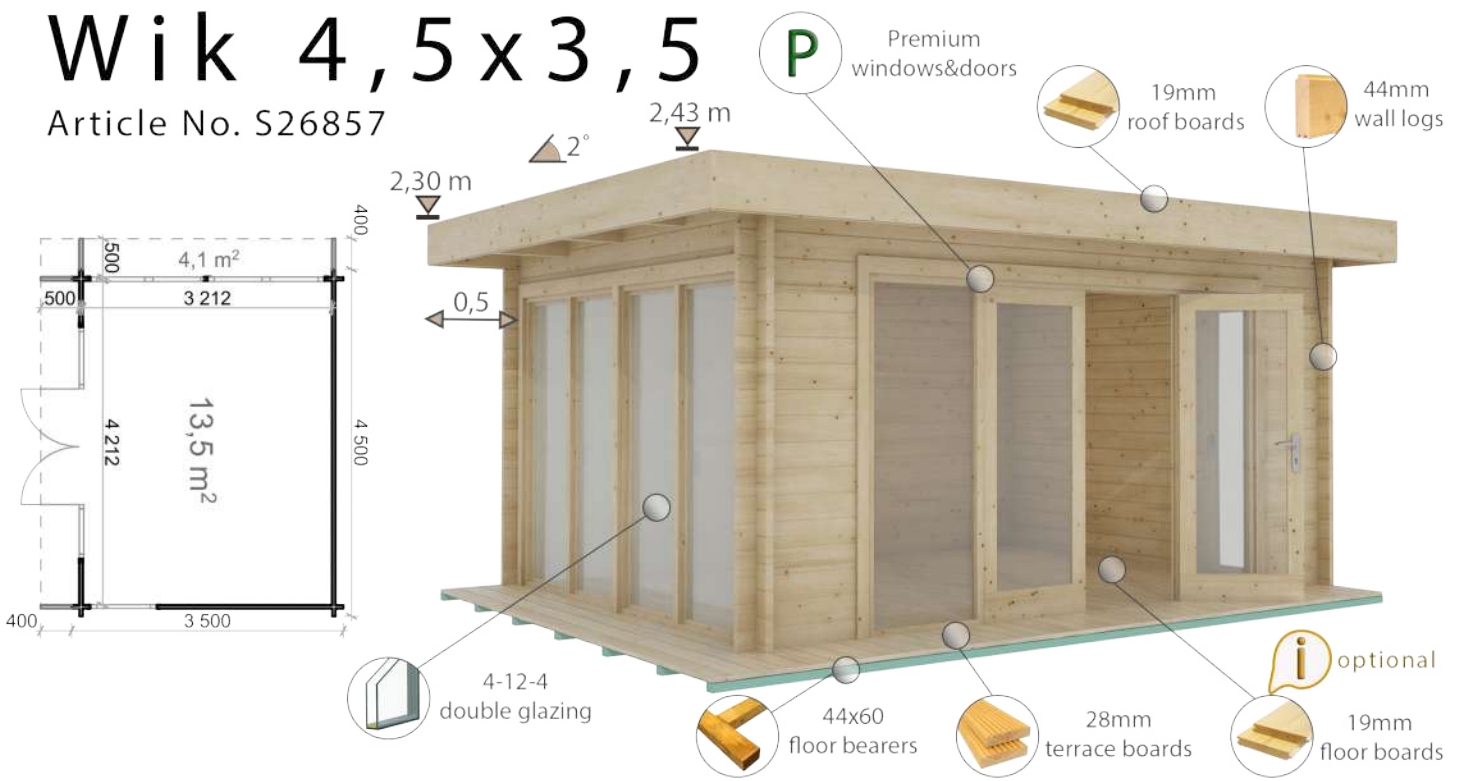

Project specification:
 External measures: 4,5x3,5 m
 Base footprint: 4,3x3,3 m
 Internal house area: 13,5 m²
 Terrace: 4,1m²
 External wall area: 25 m²
 Roof area: 19 m²

Windows and doors:
 Door: 1 quadruple 100% glass
 1,98x3,0 m
 Window: 2 double 1,98x1,5 m and 1
 single 1,98x0,85 m
 Threshold: covered with steel

Total height < 2,5 m:
 Installation kit:
 Storm braces:

*See optional products page 71



Optional products

For office/studio

Wall	Name	Article No.	Dipping (pine colour)	Bitumen roof tiles	Underlayer	EPDM roof cover	Metal roof cover	Rain gutters	Quality of windows and doors	Insulation
4 4	Agoti 5x3	S26832	●			● 16m ²		●	P+, HQ*, PVC*	Walls/roof/floor
4 4	Bergen 4,2x8	S26271	●			● 35m ²		●	P+, HQ*, PVC*	Walls/roof/floor
4 4	Emily 4,04x7,08	S26276	●	● 42m ²	● 41m'		● 37m ²	●	P+, HQ*, PVC*	Walls/roof/floor
4 4	Lille 6x3,5	S25470	●	● 33m ²	● 33m'		● 30m ²	●	P+, HQ*, PVC*	Walls/roof/floor
4 4	Nuuk 5x3,84	S26835	●			● 21m ²		●	P+, HQ*, PVC*	Walls/roof/floor
4 4	Oden 5x3,5	S26851	●	● 24m ²	● 24m'		● 22m ²	●	P+, HQ*, PVC*	Walls/roof/floor
4 4	Sydney 3,8x3,8	S26296	●			● 21m ²		●	P+, HQ*, PVC*	Walls/roof/floor
4 4	Togo 3x3	S26835	●			● 10m ²		●	P+, HQ*, PVC*	Walls/roof/floor
4 4	Wik 4,5x3,5	S26857	●			● 20m ²		●	P+, HQ*, PVC*	Walls/roof/floor



*Note: HQ or PVC windows&doors quality option is available if wall insulation is included.

Summer house/chalet



20-40
m²

40-60
m²

60+
m²

20-40m² p.74-77



Alma 7,05x8

p.74



Louise 6x6

p.75



Lukas 6,5x7,7

p.76



Veronica 5x6

p.77

40-60m² p.78-87



Almeria 5,96x8,83

p.78



Gustav A&B series

p.79-82



Iberica T2 6,36x8,86

p.83



Maja 7,4x10

p.84



Max 5,6x6,6

p.85



Olga 8x9

p.86



Scarlett 7x10,2

p.87

60+m² p.88-90



Iberica T3 7,92x11,84

p.88



Jennifer 10,5x8,52

p.89



Markus 7,1x11,1

p.90

Alma 7,05x8

Article No. S26197

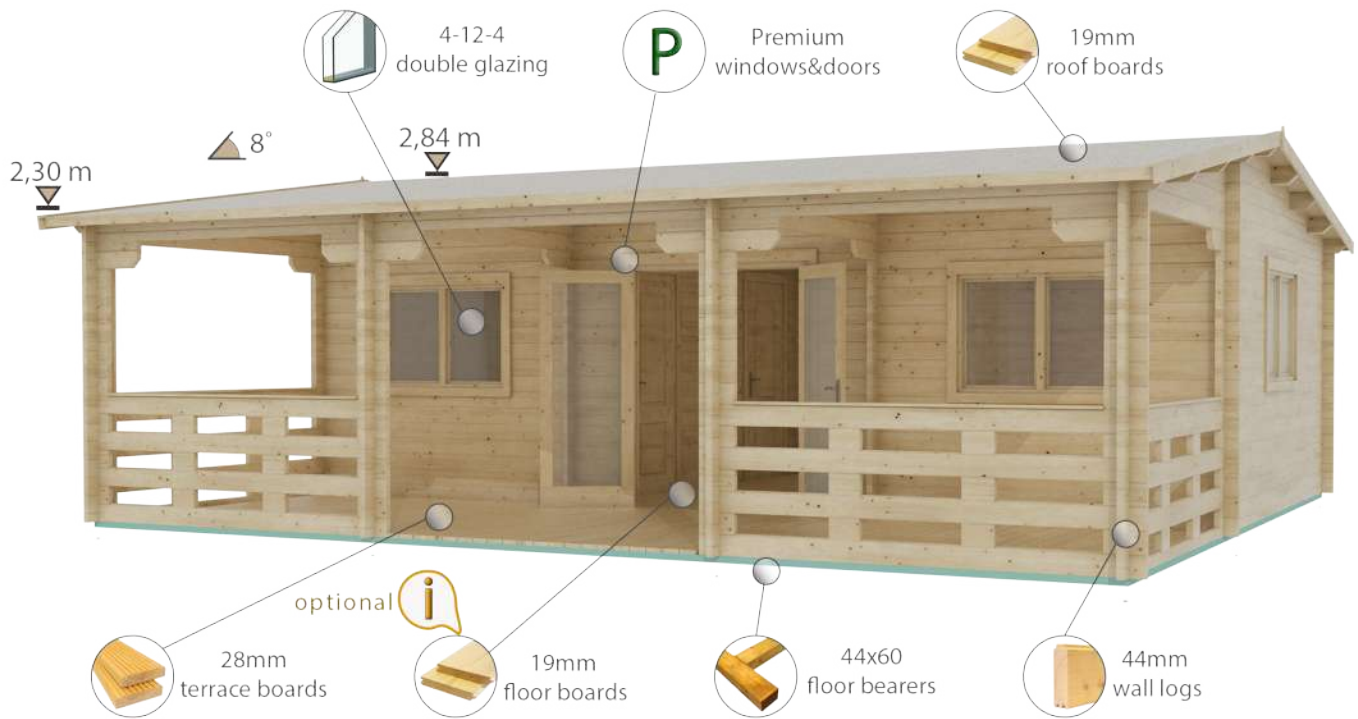

Project specification:

External measures: 7,05x8 m
 Base footprint: 6,85x7,8 m
 Internal house area: 32,1 m²
 Terrace: 19,3 m²
 External wall area: 57 m²
 Roof area: 61 m²

Windows and doors:

Door: 1 double 100% glass 1,98x1,6 m and 2 single full wood 1,98x0,85 m
 Window: 1 single 0,52x0,5 m and 3 double 0,92x1,3 m
 Threshold: covered with steel

Installation kit:

Storm braces:

*See optional products pages 91

Louise 6x6

Article No. S26777

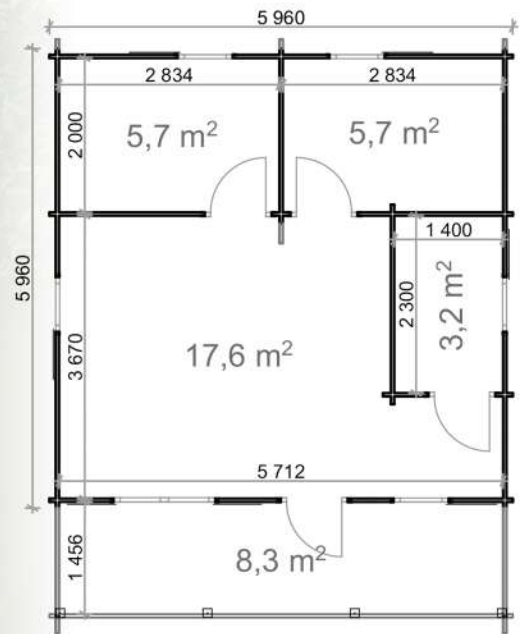
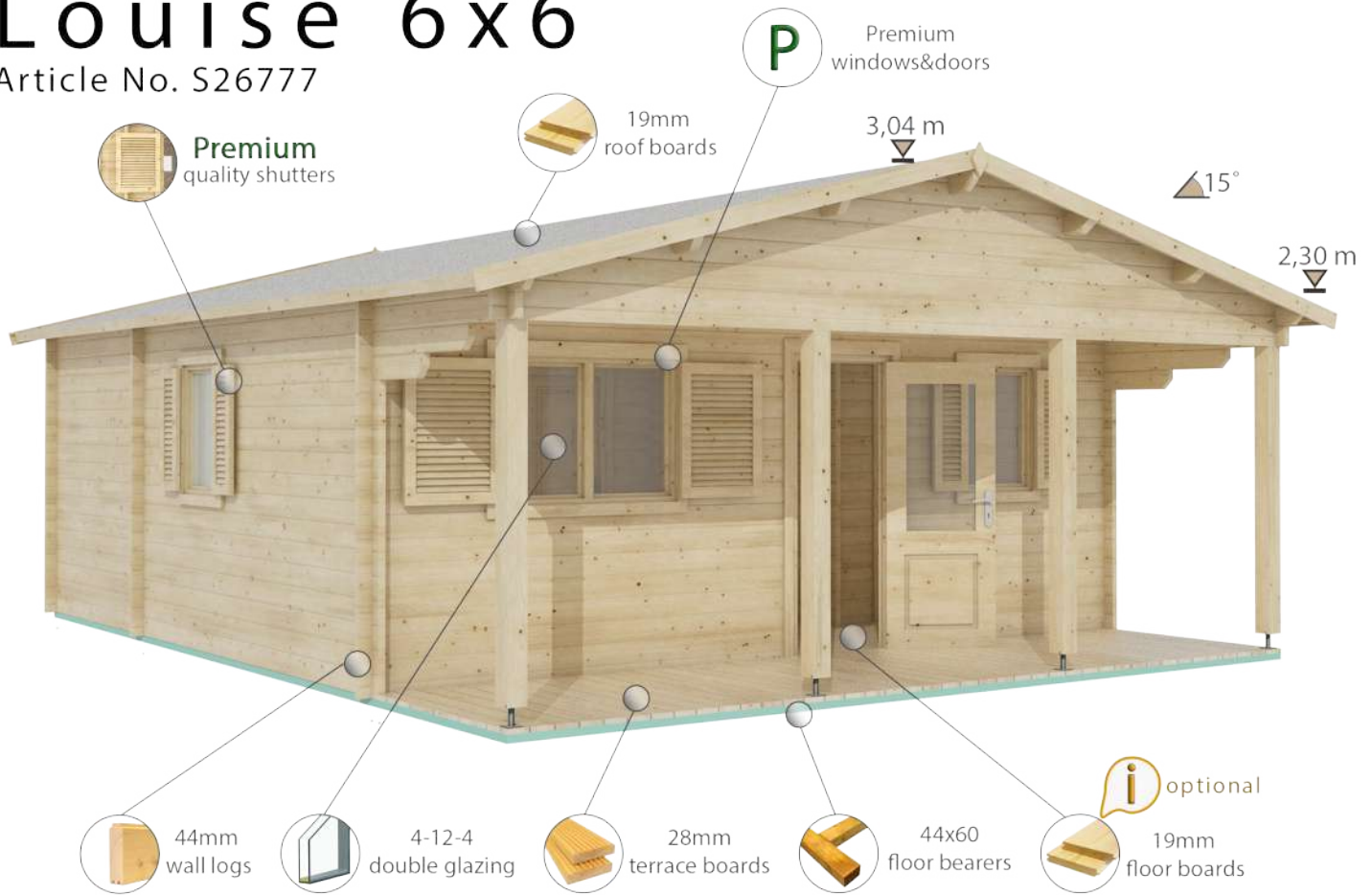

Project specification:

External measures: 5,96x5,96 m
 Base footprint: 5,8x5,8 m
 Internal house area: 32,2 m²
 Terrace: 8,3 m²
 External wall area: 55 m²
 Roof area: 50 m²

Windows and doors:

Door: 1 single 50% glass 1,98x0,85 m and 3 single full wood 1,98x0,85 m
 Window: 5 single 0,92x0,7 m and 1 double 0,92x1,3 m
 Threshold: covered with steel

Possible reverse montage:

Installation kit:

Shutters kit:

*See optional products pages 91

Lukas 6,5x7,7

Article No. S26241

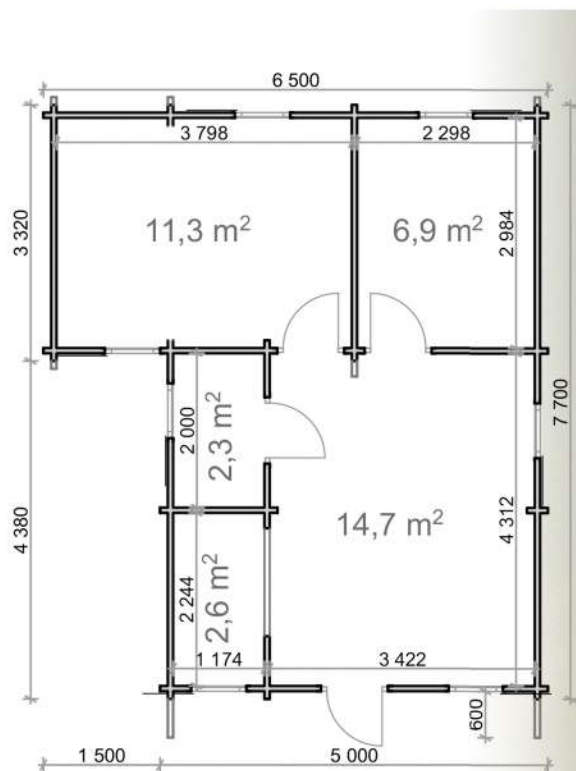
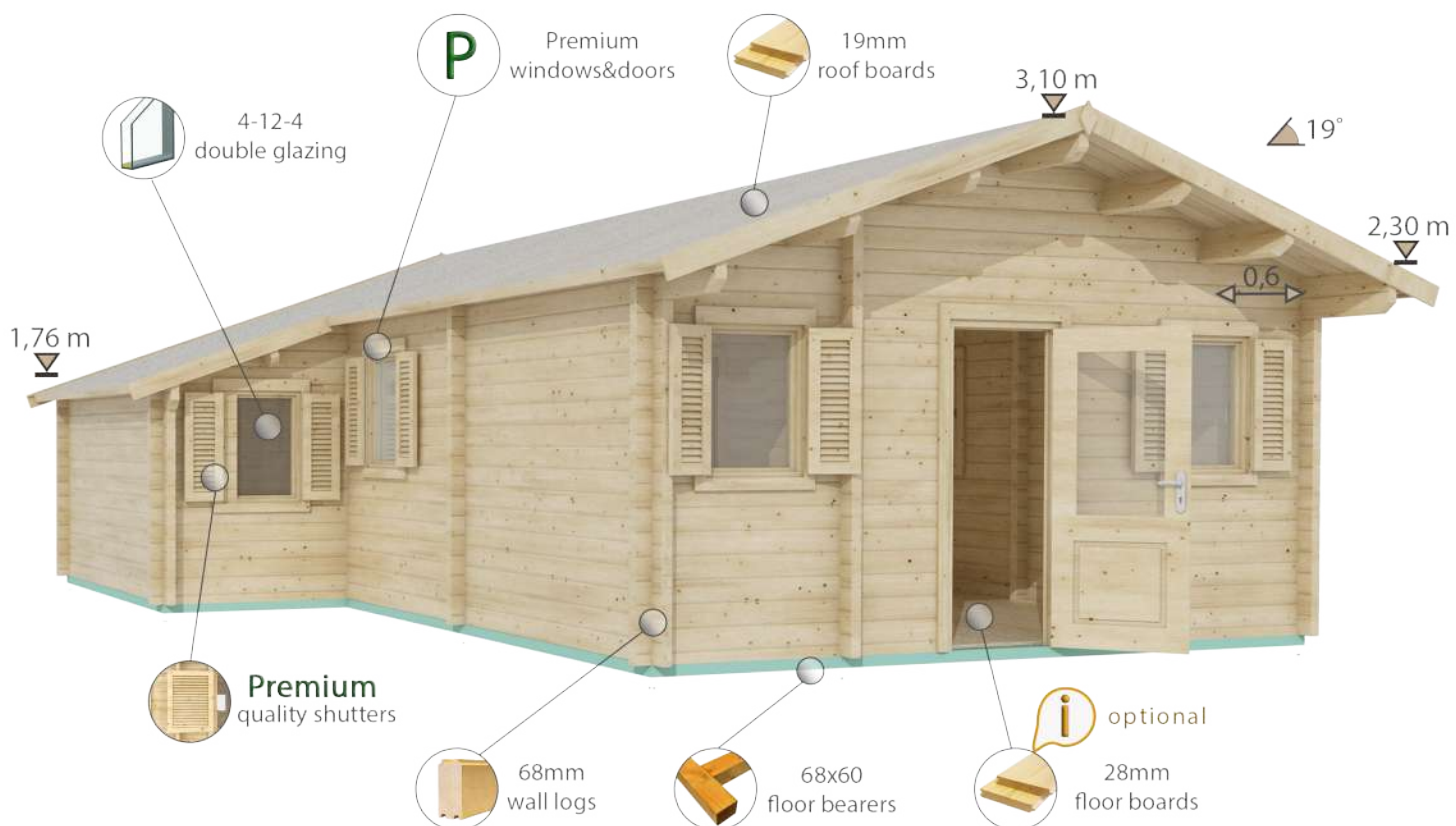

Project specification:

External measures: 6,5x7,7 m
 Base footprint: 6,3x7,5 m
 Internal house area: 37,8 m²
 External wall area: 64 m²
 Roof area: 52,3 m²

Windows and doors:

Door: 1 single 50% glass 1,98x0,85 m and 3 single full wood 1,98x0,85 m
 Window: 7 single 0,92x0,7 m
 Threshold: covered with steel

Installation kit:

Shutters kit:

*See optional products pages 91

Almeria 5,96x8,83

Article No. S26198

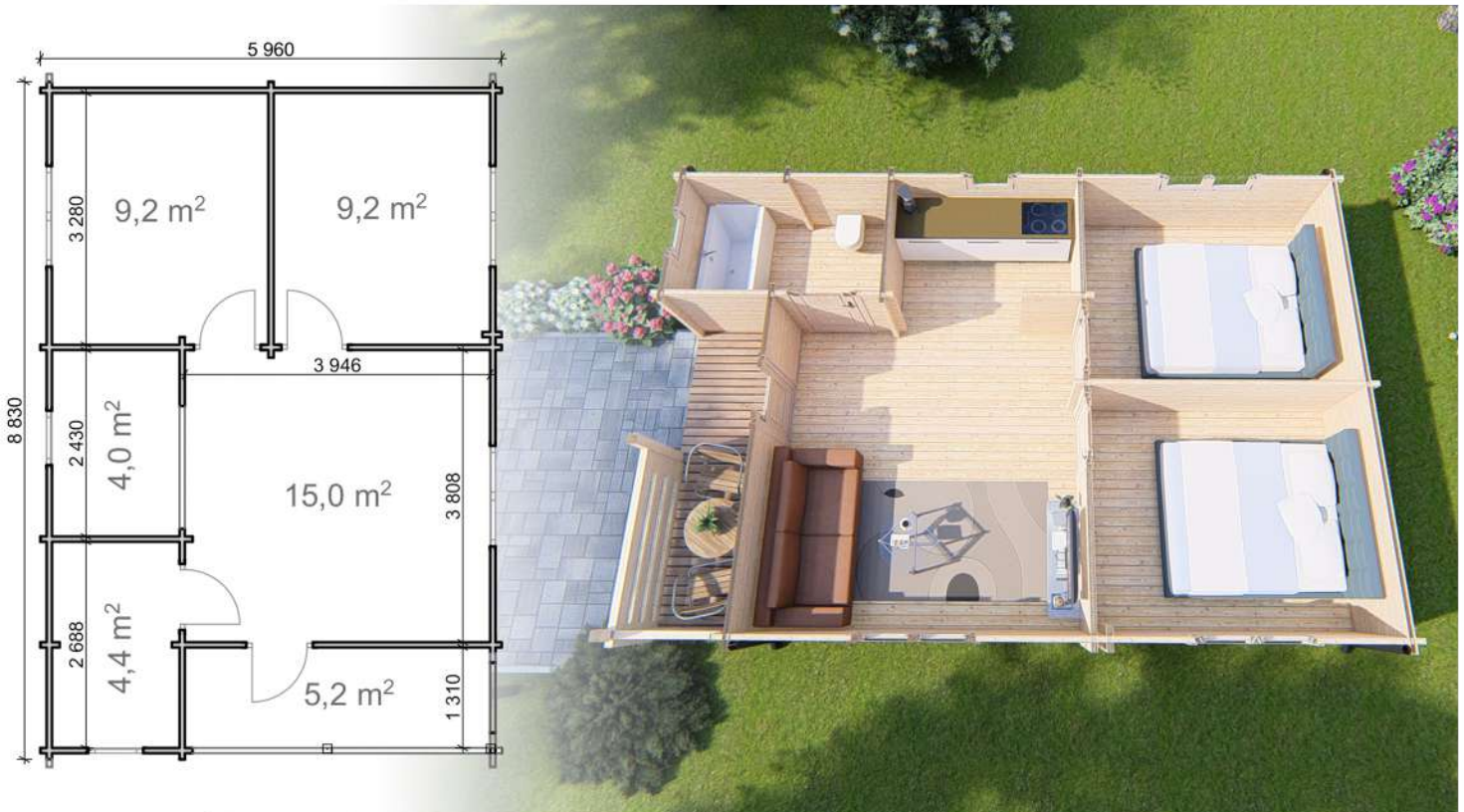
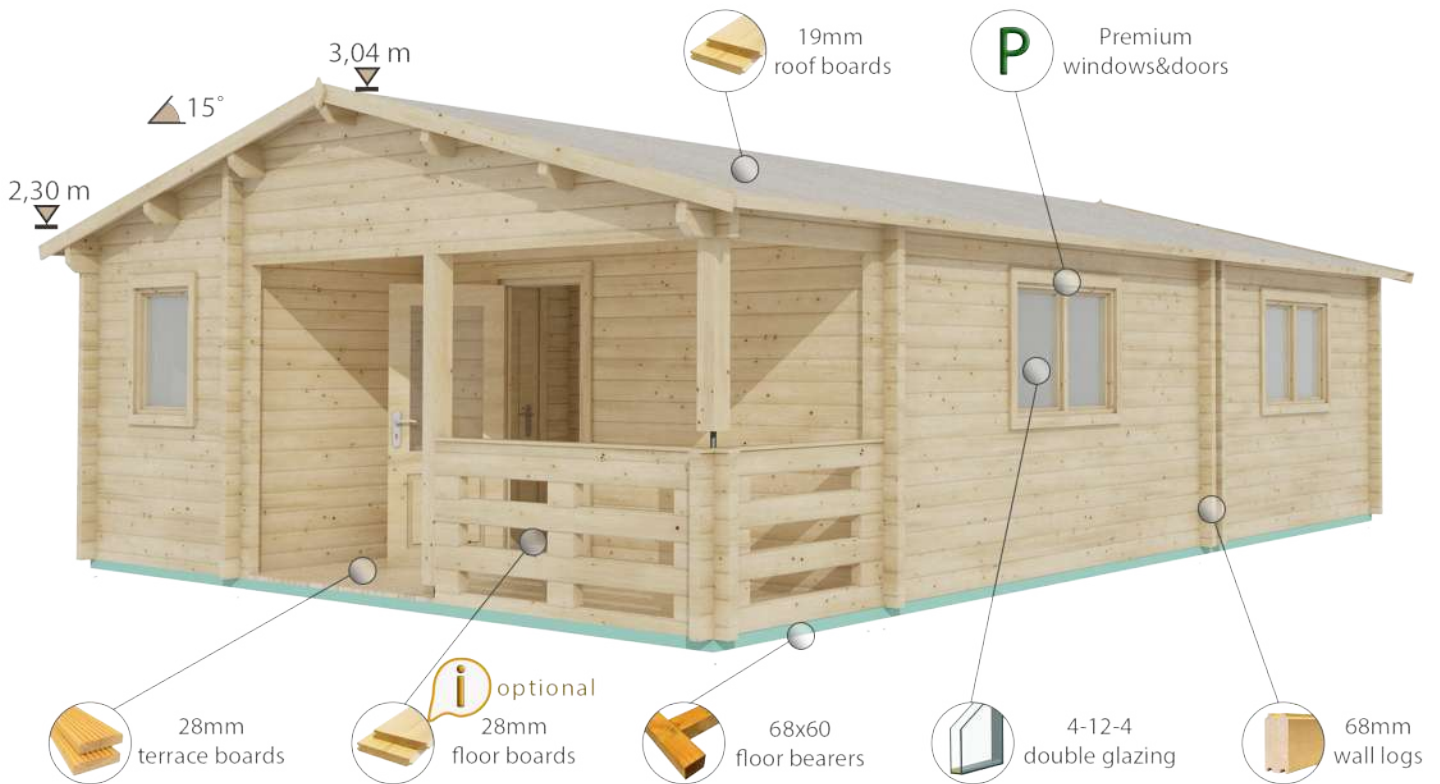

Project specification:

External measures: 5,96x8,83 m
Base footprint: 5,8x8,67 m
Internal house area: 41,8 m²
Terrace: 5,2 m²
External wall area: 70 m²
Roof area: 59,1 m²

Windows and doors:

Door: 1 single 50% glass 1,98x0,85 m and 3 single full wood 1,98x0,85 m
Window: 2 single 0,92x0,7 m and 3 double 0,92x1,3 m
Threshold: covered with steel

Installation kit:

*See optional products pages 91

Gustav A series

*44mm and 68mm options are available

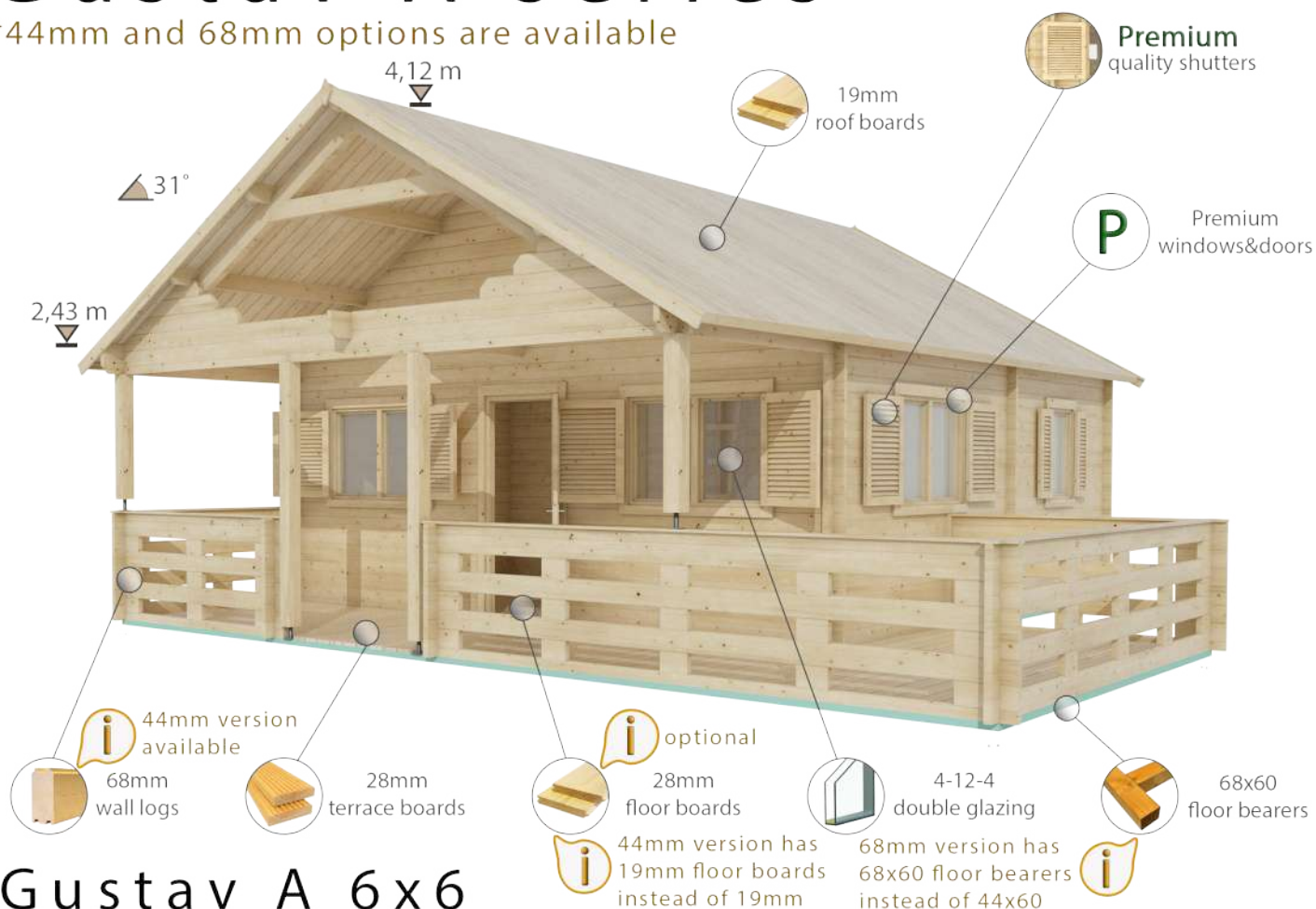

Gustav A 6x6

44mm

Article No. S26226

68mm

Article No. S26227

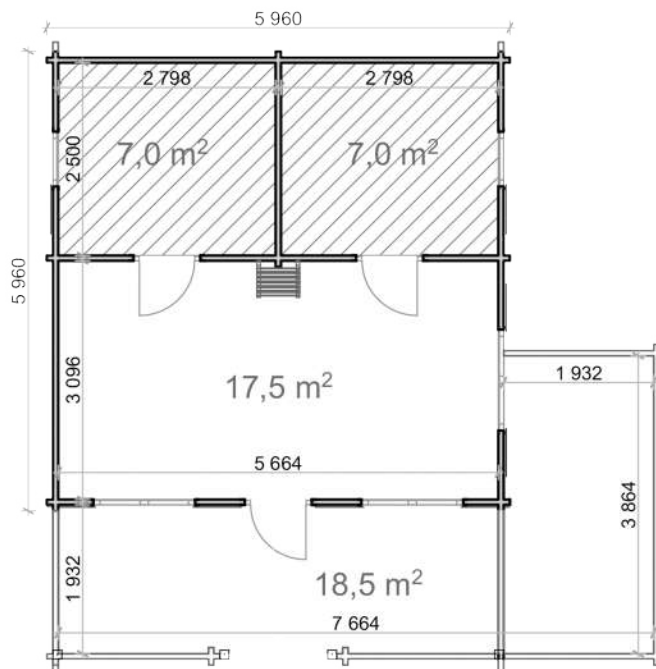
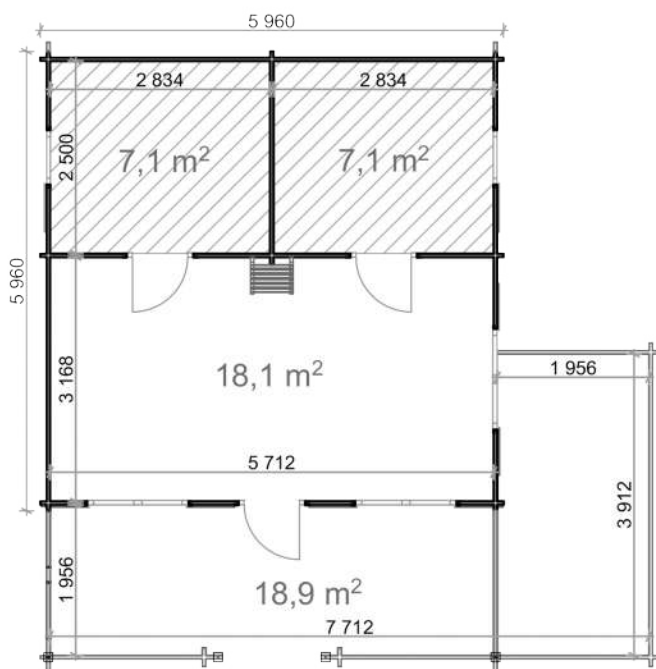

Project specification:

External measures: 5,96x5,96 m
 Base footprint: 5,8(+2)x5,8(+2) m
 Internal house area: 32 m² + 14 m² (attic floor)
 Terrace: 18,5 m²
 External wall area: 65 m²
 Roof area: 59,4 m²

Windows and doors:

Door: 1 single 50% glass 1,98x0,85 m and 2 single full wood 1,98x0,85 m
 Window: 1 single 0,52x0,5 m, 2 single 0,92x0,7 m and 3 double 0,92x1,3 m
 Threshold: covered with steel

Attic floor:

Ladder:

Installation kit:

Shutters kit:

*See optional products pages 91

Gustav A 6x6



Gustav A 6x6 WC

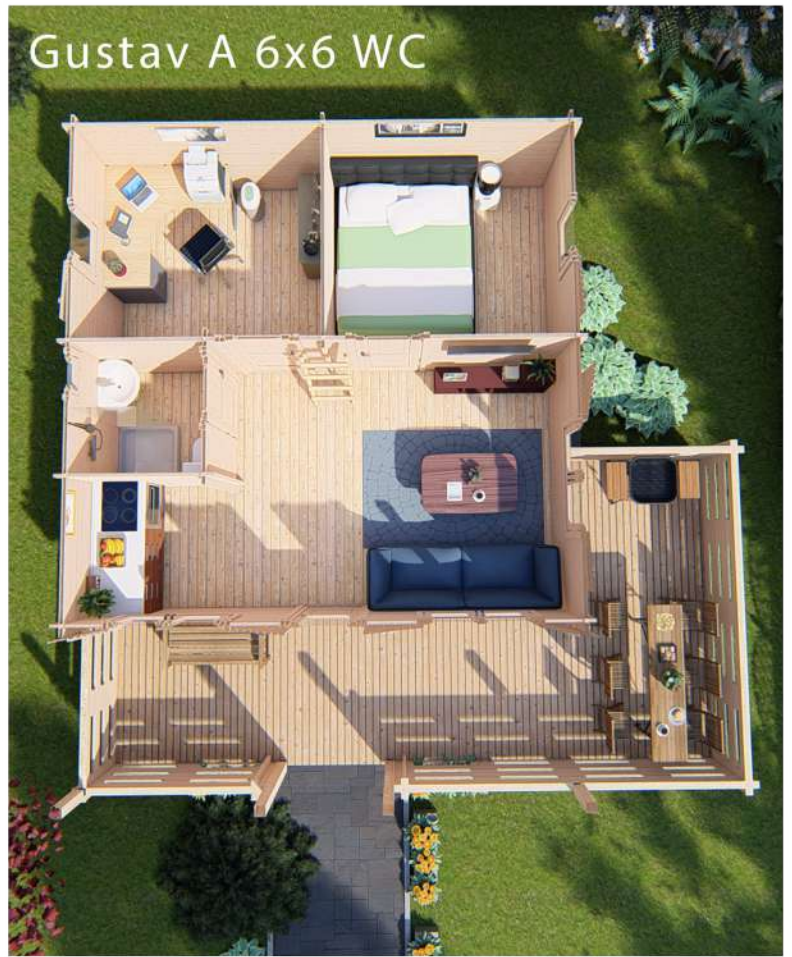

Gustav A 6x6 WC

44mm

Article No. S29362

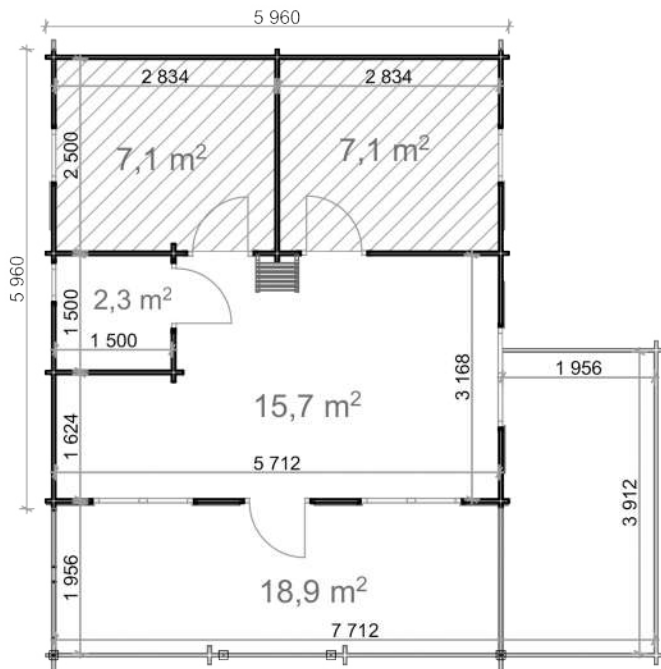

68mm

Article No. S29363

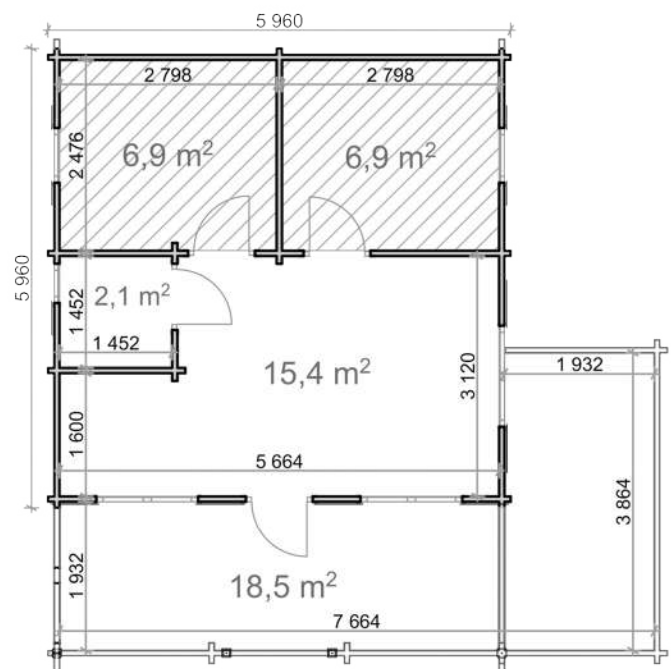

Project specification:

External measures: 5,96x5,96 m

Base footprint: 5,8(+2)x5,8(+2) m

Internal house area: 32 m² + 14 m² (attic floor)

Terrace: 18,5 m²

External wall area: 65 m²

Roof area: 59,4 m²

Windows and doors:

Door: 1 single 50% glass 1,98x0,85 m and 3 single full wood 1,98x0,85 m

Window: 2 single 0,52x0,5 m, 2 single 0,92x0,7 m and 3 double 0,92x1,3 m

Threshold: covered with steel

Attic floor:

Ladder:

Installation kit:

Shutters kit:

*See optional products pages 91

Gustav B series

*44mm and 68mm options are available

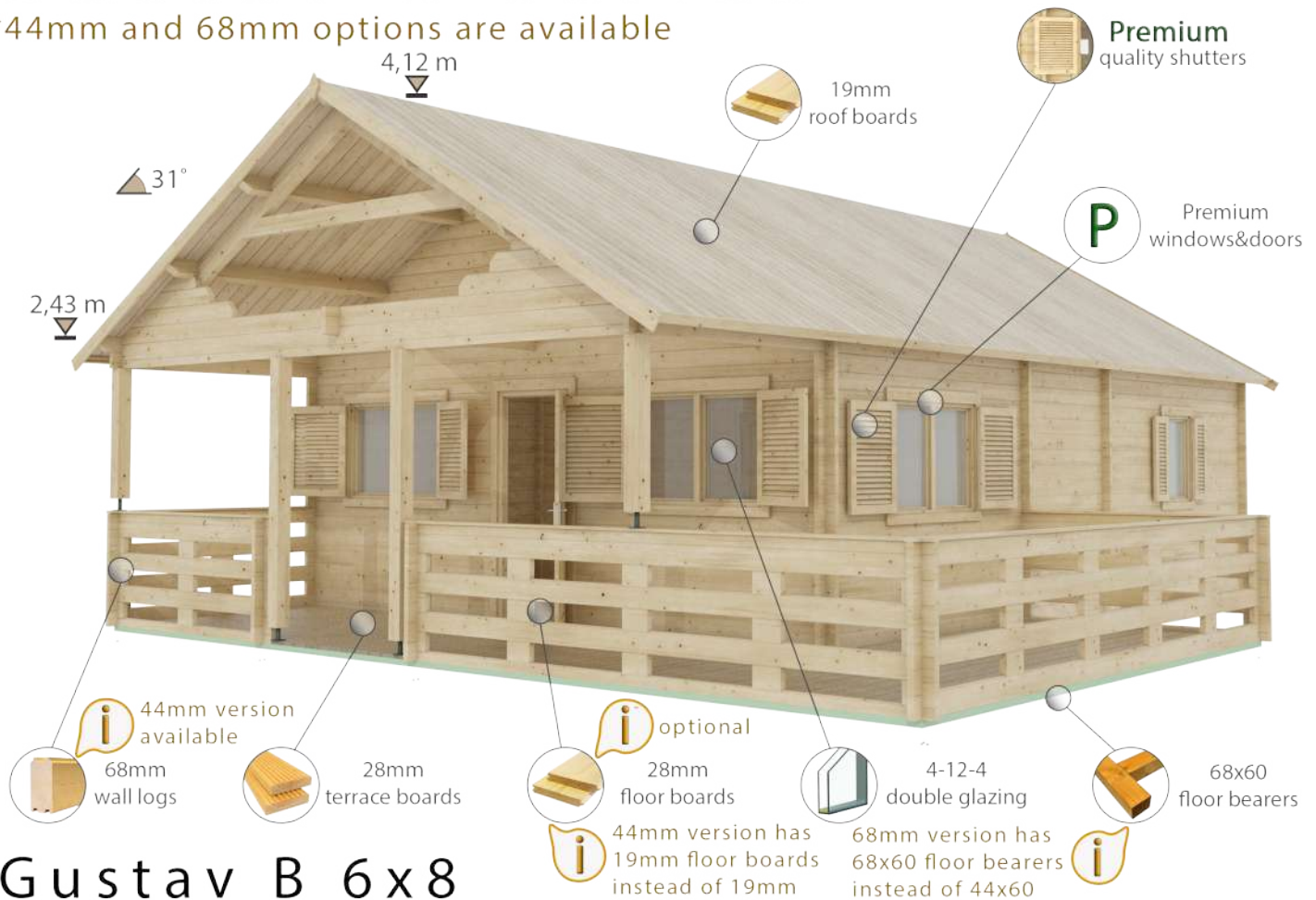

Gustav B 6x8

44mm

Article No. S26225

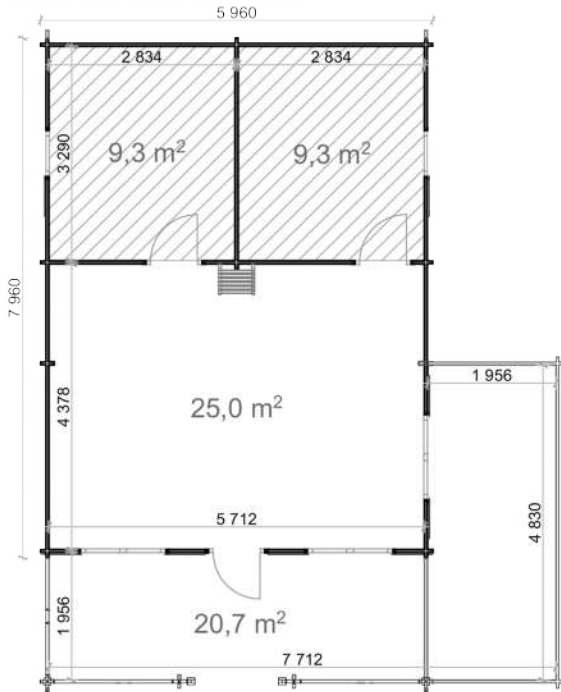

68mm

Article No. S26283

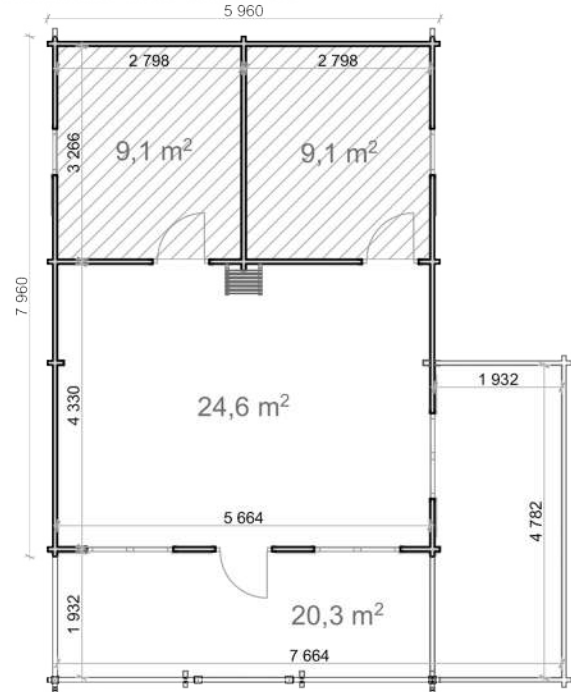

Project specification:

External measures: 5,96x7,96 m
 Base footprint: 5,8(+2)x7,8(+2) m
 Internal house area: 44 m² + 19 m² (attic floor)
 Terrace: 20,7 m²
 External wall area: 74 m²
 Roof area: 74,3 m²

Windows and doors:

Door: 1 single 50% glass 1,98x0,85 m and 2 single full wood 1,98x0,85 m
 Window: 1 single 0,52x0,5 m, 2 single 0,92x0,7 m and 3 double 0,92x1,3 m
 Threshold: covered with steel

Attic floor:

Ladder:

Installation kit:

Shutters kit:

*See optional products pages 91

Gustav B 6x8



Gustav B 6x8 WC



Gustav B 6x8 WC

44mm

Article No. S29364

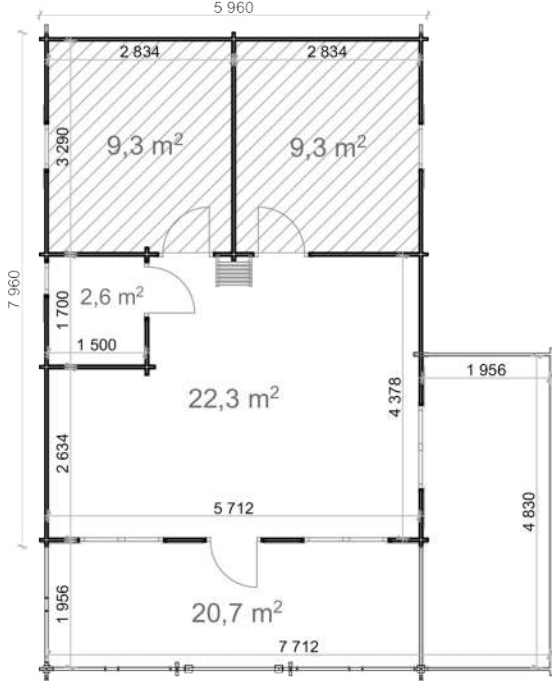

68mm

Article No. S29365

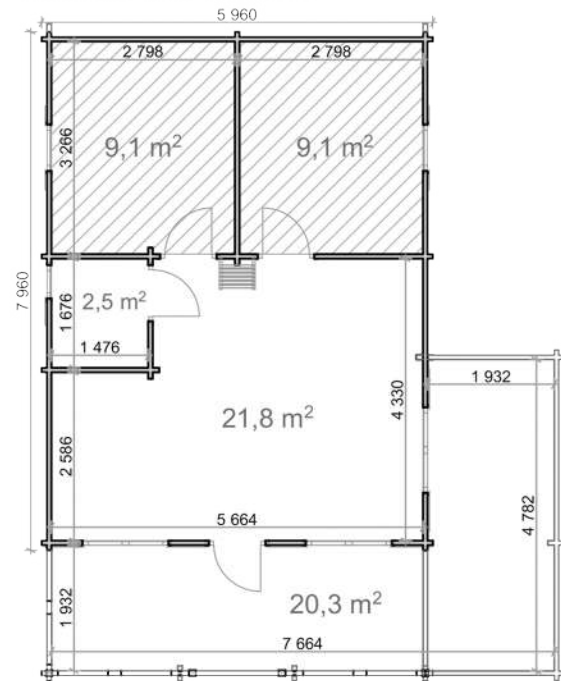

Project specification:

External measures: 5,96x7,96 m

Base footprint: 5,8(+2)x7,8(+2) m

Internal house area: 44 m² + 19 m² (attic floor)

Terrace: 20,7 m²

External wall area: 74 m²

Roof area: 74,3 m²

Windows and doors:

Door: 1 single 50% glass 1,98x0,85 m and 3 single full wood 1,98x0,85 m

Window: 2 single 0,52x0,5 m, 2 single 0,92x0,7 m and 3 double 0,92x1,3 m

Threshold: covered with steel

Attic floor:

Ladder:

Installation kit:

Shutters kit:

*See optional products pages 91

Iberica T2 6,36x8,86

Article No. S26231

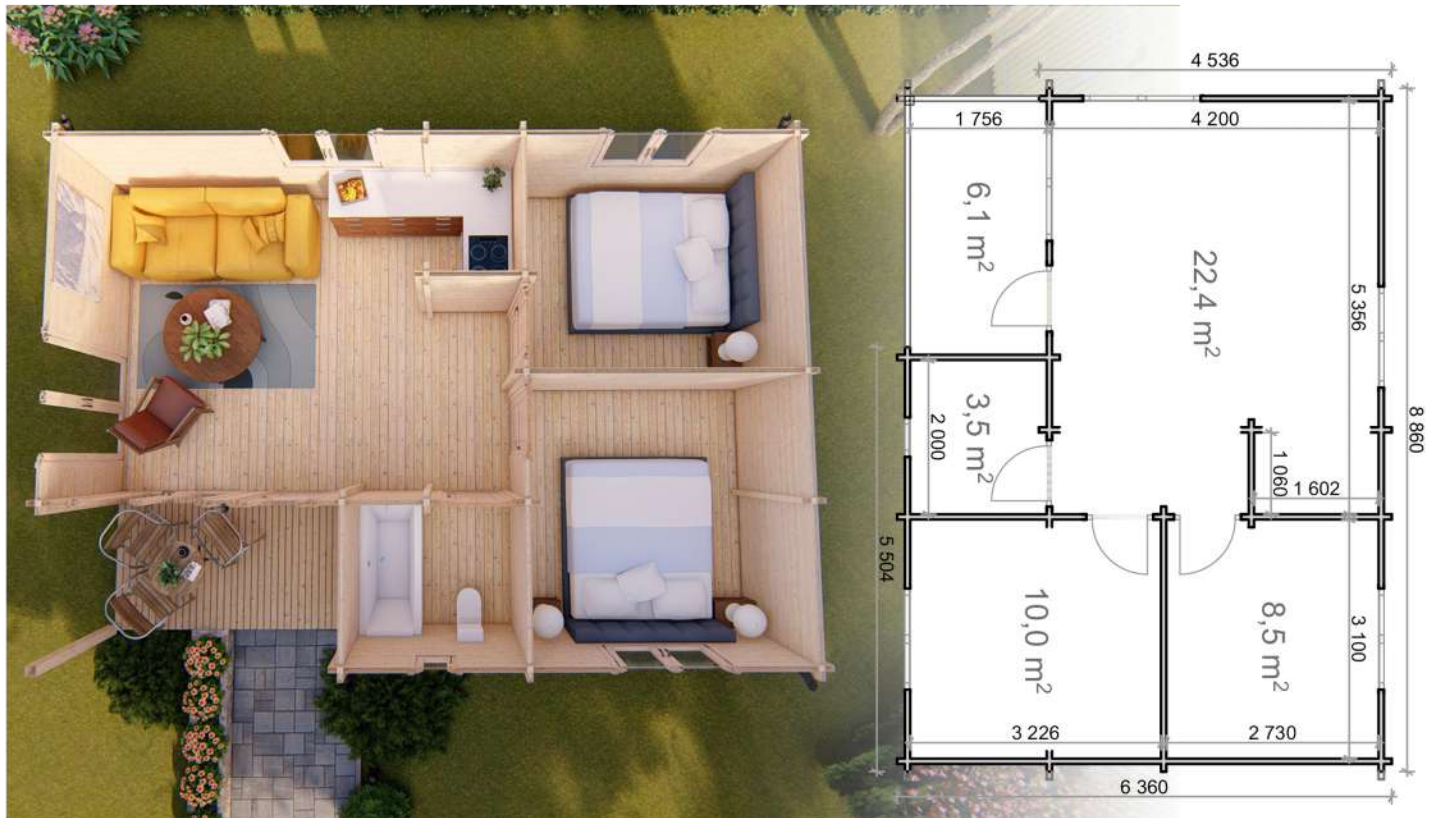
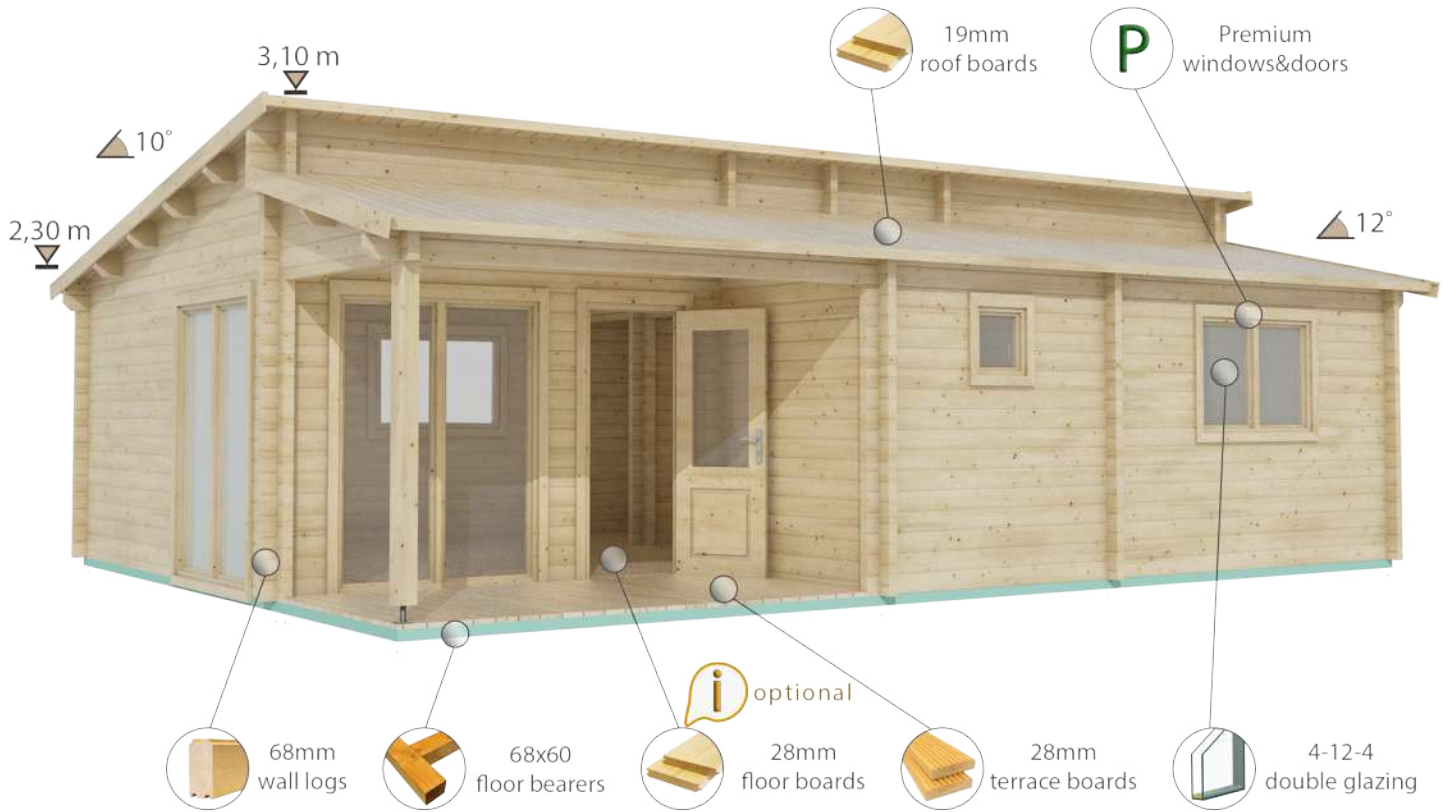

Project specification:

External measures: 6,36x8,86 m
 Base footprint: 6,16x8,66 m
 Internal house area: 44,4 m²
 Terrace: 6,1 m²
 External wall area: 68 m²
 Roof area: 62 m²

Windows and doors:

Door: 1 single 50% glass 1,98x0,85 m and 3 single full wood 1,98x0,85 m
 Window: 1 single 0,52x0,5 m, 3 double 0,92x1,3 m and 2 double 1,98x1,5 m
 Threshold: covered with steel

Installation kit:

*See optional products pages 91

Maja 7,4x10

Article No. S26243

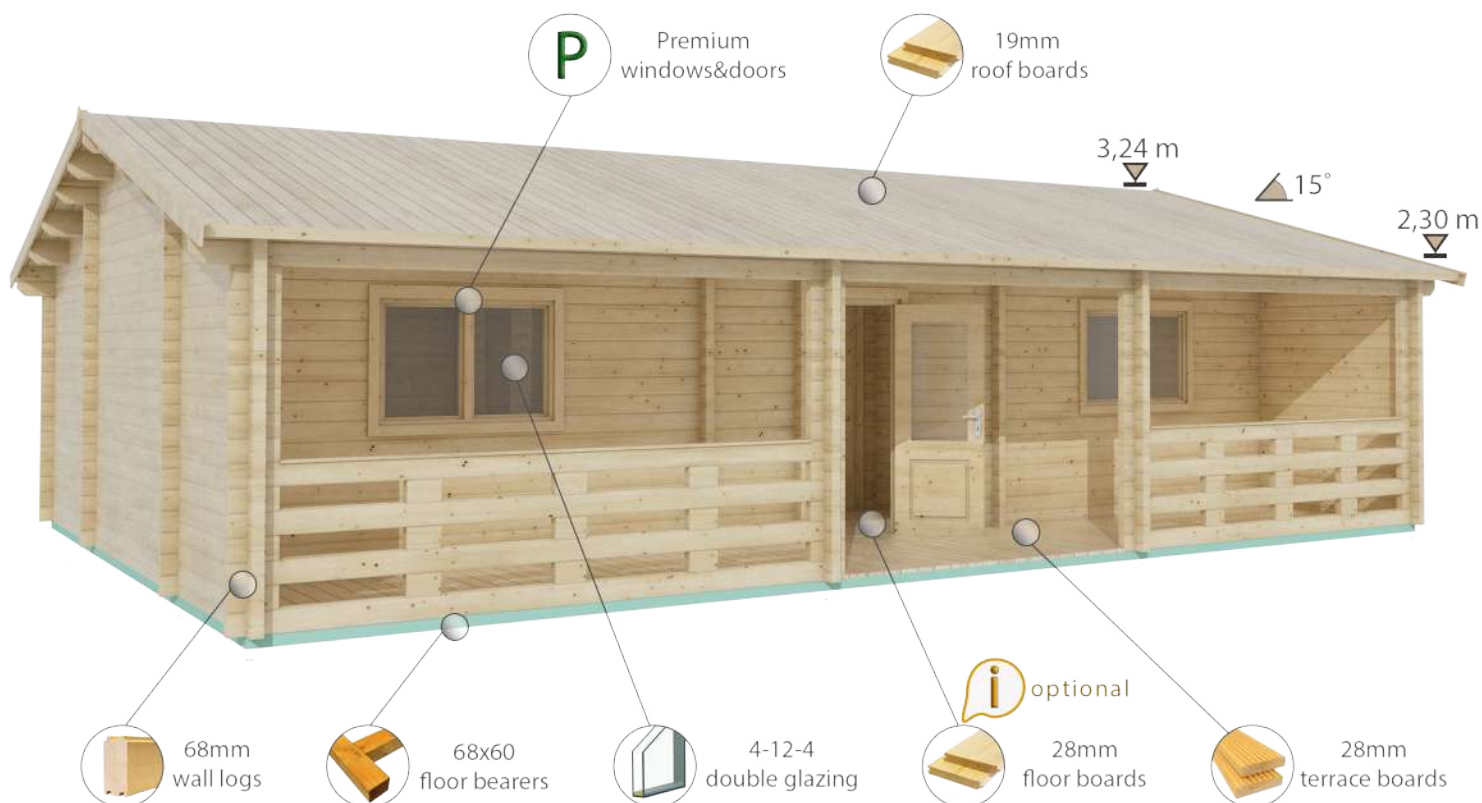

Project specification:

External measures: 7,4x10 m
 Base footprint: 7,2x9,8 m
 Internal house area: 49,8 m²
 Terrace: 16,5 m²
 External wall area: 85 m²
 Roof area: 82,9 m²

Windows and doors:

Door: 1 single 50% glass 1,98x0,85 m and 3 single full wood 1,98x0,85 m
 Window: 1 single 0,92x0,7 m and 4 double 0,92x1,3 m
 Threshold: covered with steel

Installation kit:

*See optional products pages 91

Max 5,6x6,6

Article No. S26246

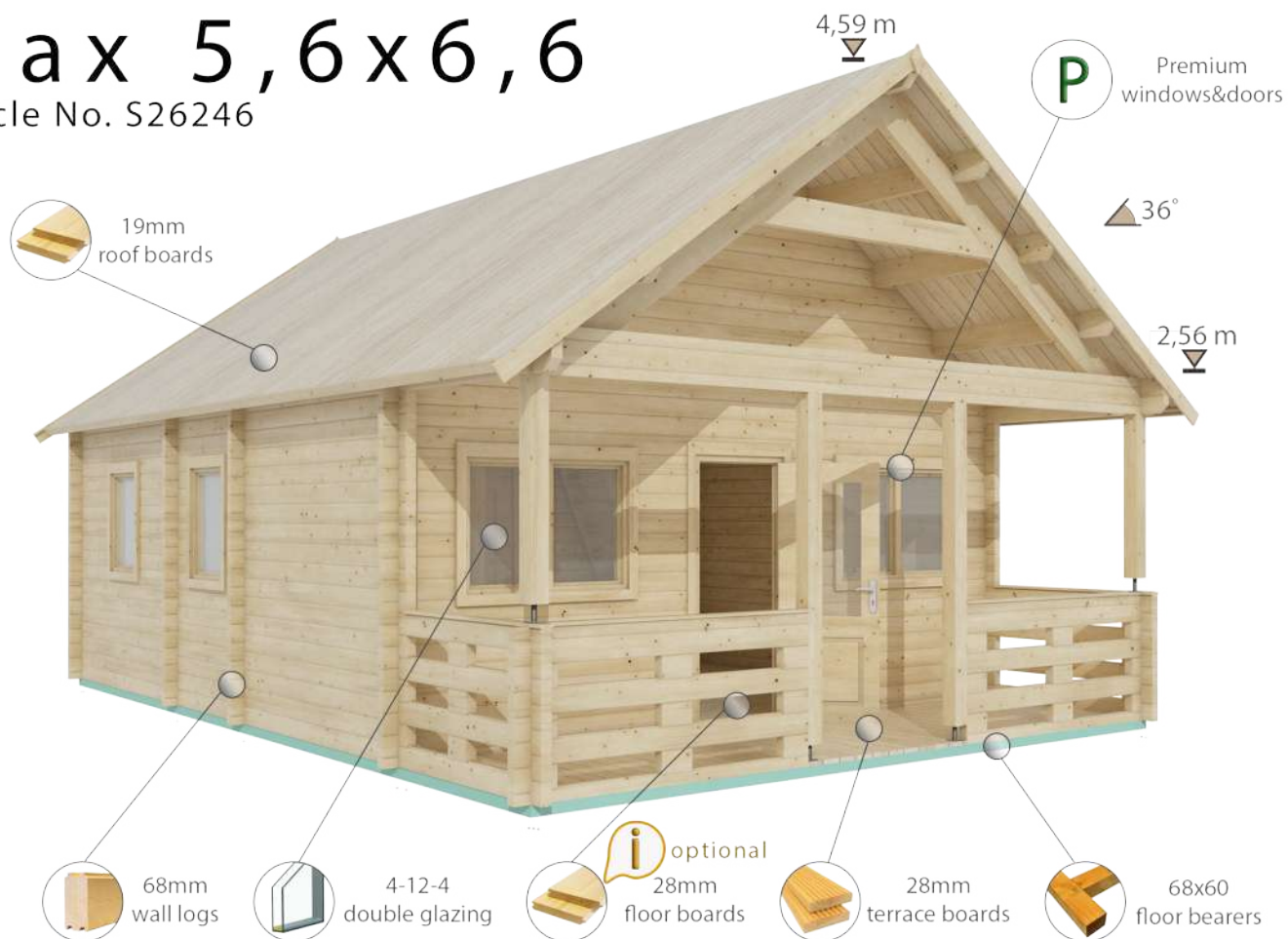

Project specification:

External measures: 5,6x6,6 m
 Base footprint: 5,4x7,9 m
 Internal house area: 32,4 m² + 15 m² (attic floor)
 Terrace: 7,5 m²
 External wall area: 74 m²
 Roof area: 60,3 m²

Windows and doors:

Door: 1 single 50% glass 1,98x0,85 m and 1 single full wood 1,98x0,85 m
 Window: 5 single 0,92x0,7 m and 2 double 0,92x1,3 m
 Threshold: covered with steel

Attic floor:

Stair (space saver):

Installation kit:

*See optional products pages 91

Olga 8x9

Article No. S27471

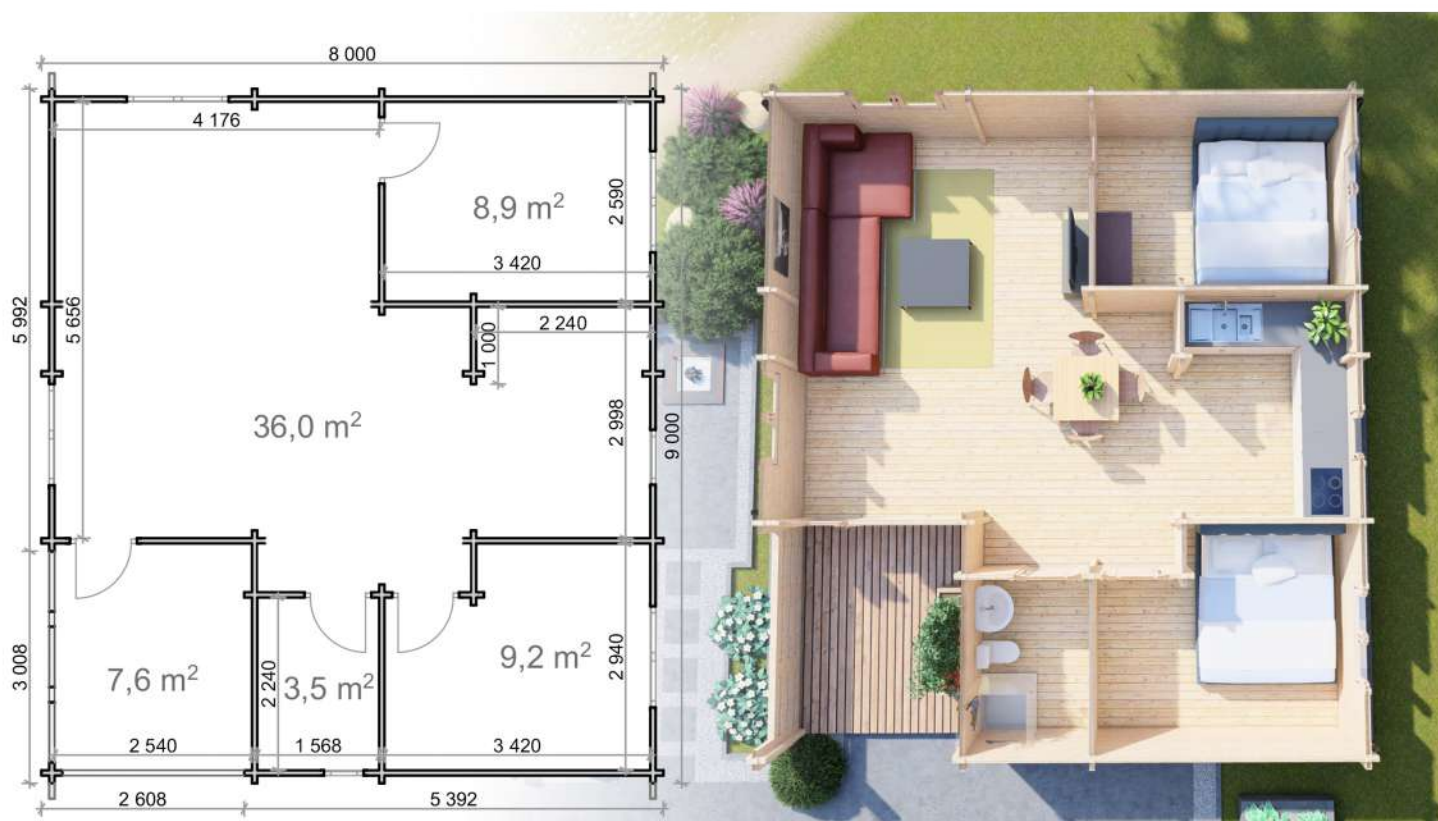
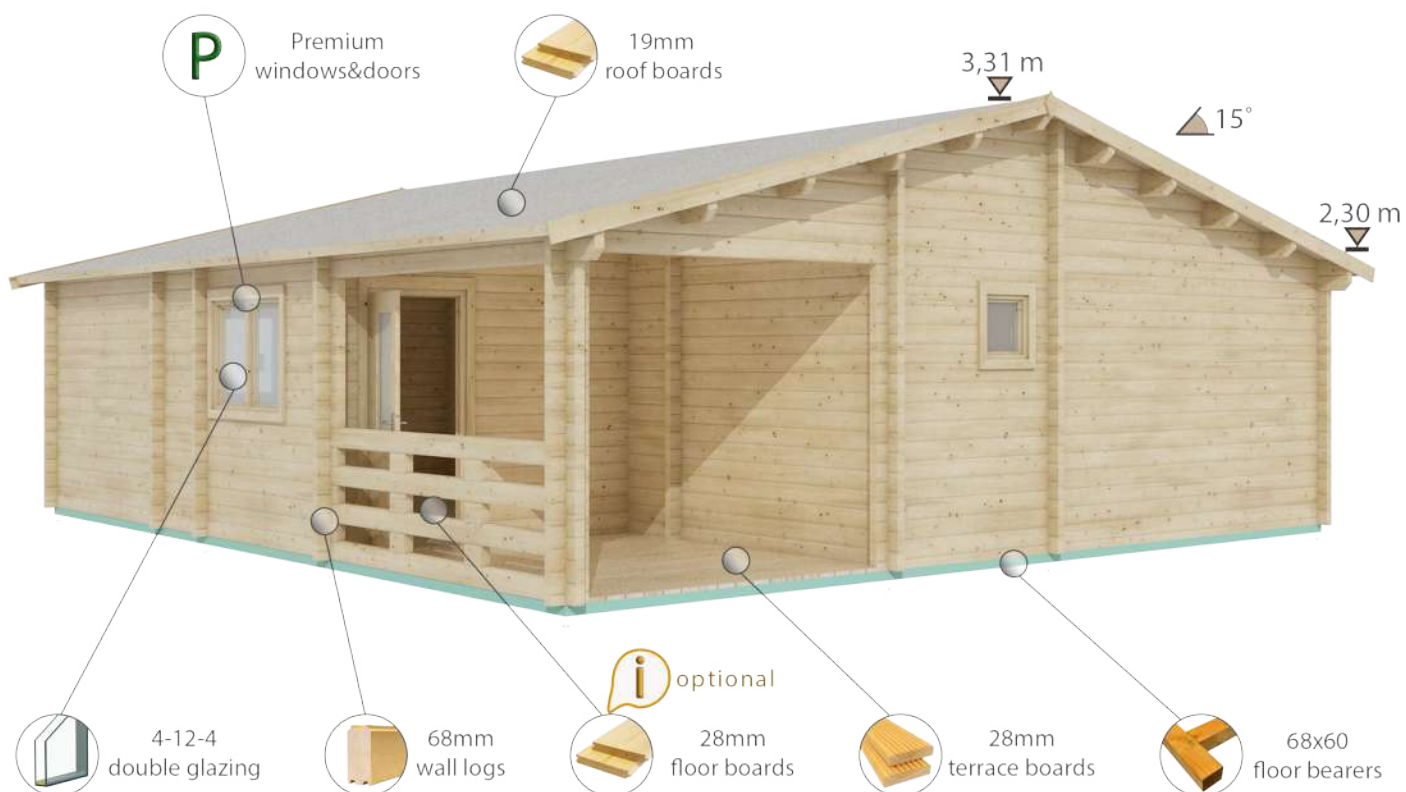

Project specification:

External measures: 8x9 m
 Base footprint: 7,8x8,8 m
 Internal house area: 57,6 m²
 Terrace: 7,6 m²
 External wall area: 83 m²
 Roof area: 81 m²

Windows and doors:

Door: 1 single 50% glass 1,98x0,85 m and 3 single full wood 1,98x0,85 m
 Window: 1 single 0,52x0,5 m, 1 single 0,92x0,7 m and 4 double 0,92x1,3 m
 Threshold: covered with steel

Installation kit:

*See optional products pages 91

Scarlett 7x10,2

Article No. S26259

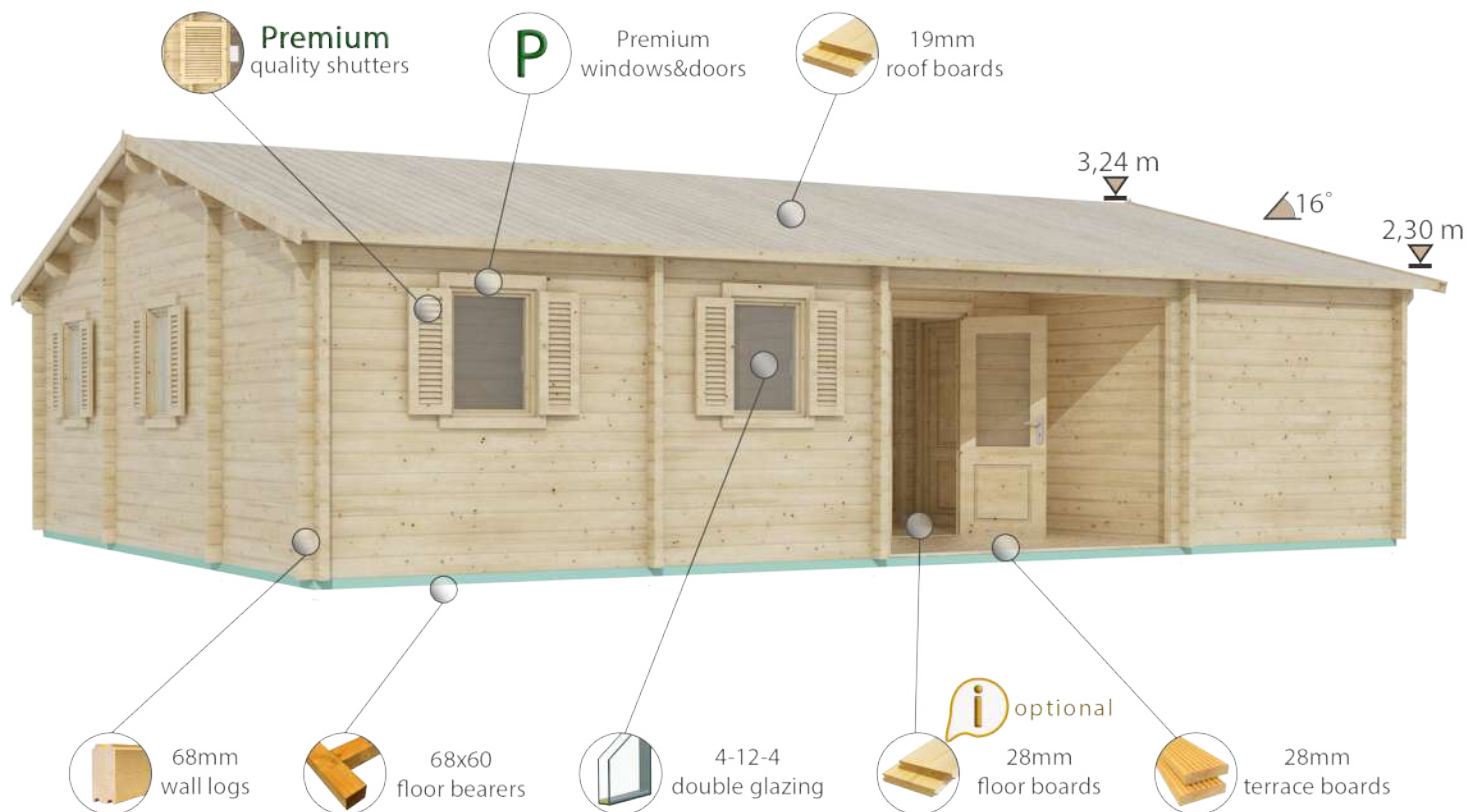

Project specification:

External measures: 7x10,2 m
 Base footprint: 6,8x10 m
 Internal house area: 59 m²
 Terrace: 5,3 m²
 External wall area: 88 m²
 Roof area: 78,9 m²

Windows and doors:

Door: 1 double 50% glass 1,98x1,6 m and 4 single full wood 1,98x0,85 m
 Window: 6 single 0,92x0,7 m and 1 double 0,92x1,3 m
 Threshold: covered with steel

Installation kit:

Shutters kit:

*See optional products pages 91

Iberica T3 7,92x11,84

Article No. S26230

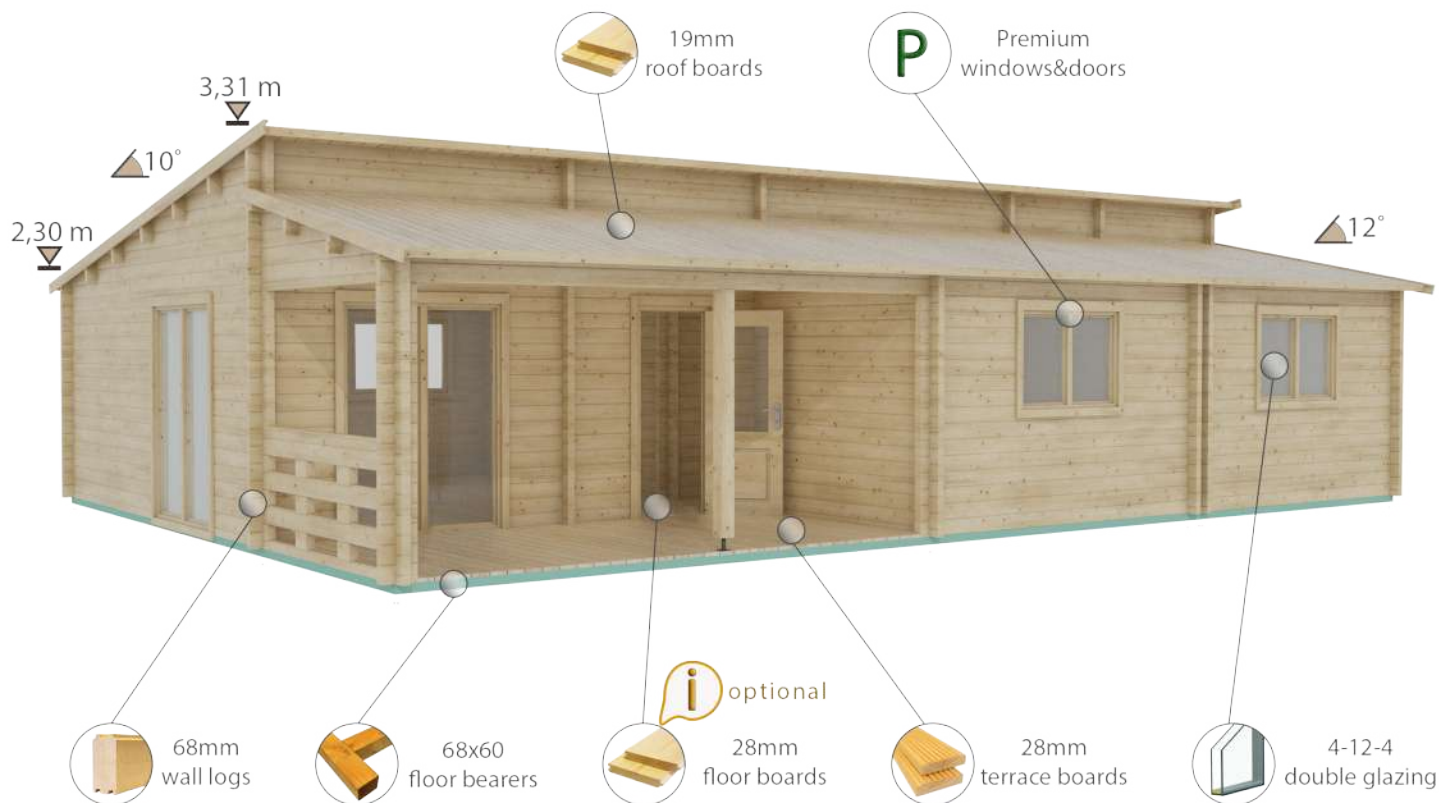

Project specification:

External measures: 7,92x11,84 m
Base footprint: 7,72x11,64 m
Internal house area: 73,8 m²
Terrace: 11 m²
External wall area: 89 m²
Roof area: 102 m²

Windows and doors:

Door: 1 single 50% glass 1,98x0,85 m and 5 single full wood 1,98x0,85 m
Window: 2 single 0,92x0,7 m, 4 double 0,92x1,3 m and 2 double 1,98x1,5 m
Threshold: covered with steel

Installation kit:

*See optional products pages 91

Jennifer 10,5x8,52

Article No. S26205



Project specification:

External measures: 10,5x8,52 m
 Base footprint: 10,3x8,32 m
 Internal house area: 65,4 m²
 Terrace: 16,8m²
 External wall area: 96 m²
 Roof area: 98,2 m²

Windows and doors:

Door: 1 single 50% glass 1,98x0,85 m and 3 single full wood 1,98x0,85 m
 Window: 2 single 0,92x0,7 m and 4 double 0,92x1,3 m
 Threshold: covered with steel

Installation kit:

*See optional products pages 91

Markus 7,1x11,1

Article No. S26245

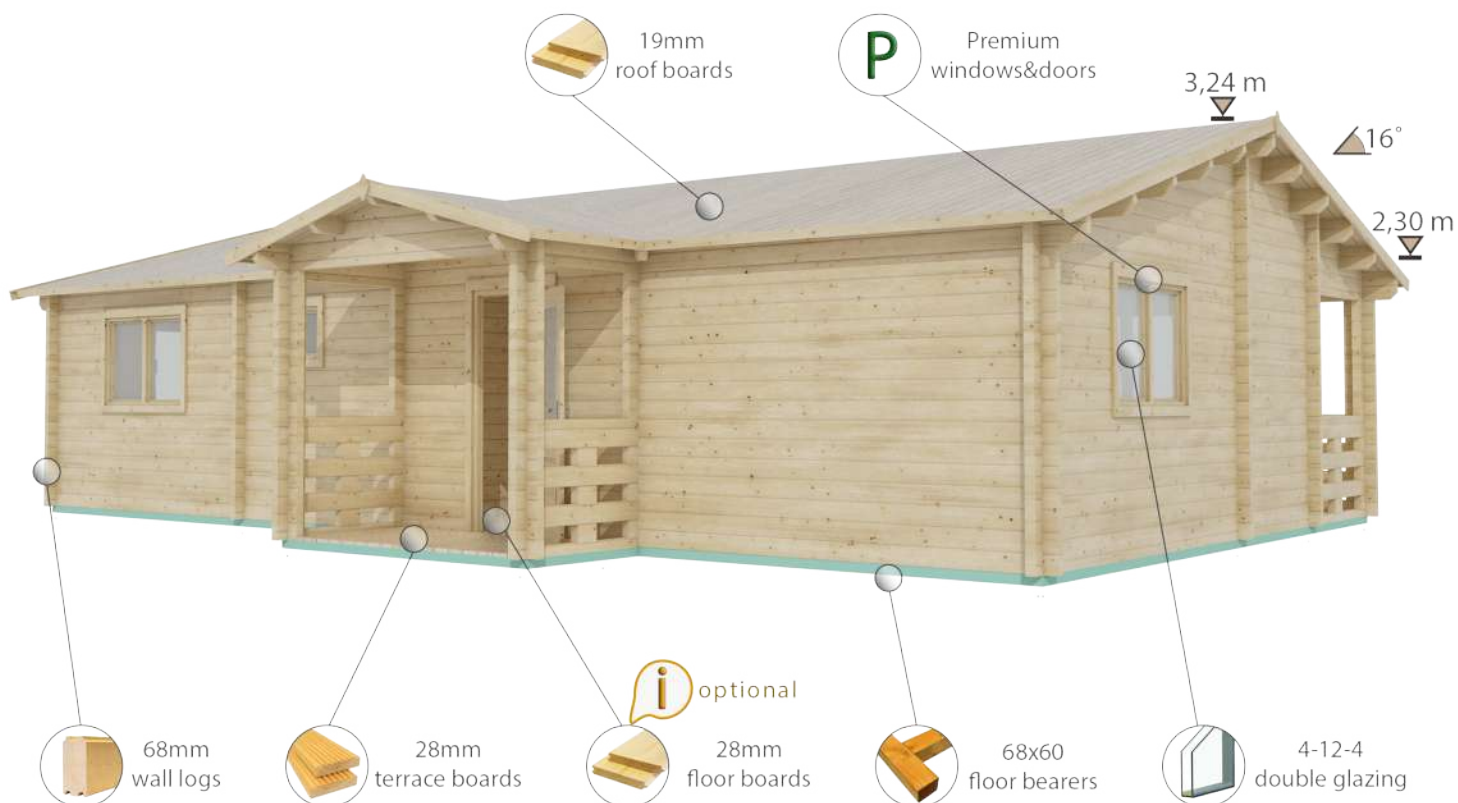

Project specification:

External measures: 7,1x11,1 m
 Base footprint: 6,9(+1,2)x10,9 m
 Internal house area: 62,1 m²
 Terrace: 12,3 m²
 External wall area: 85 m²
 Roof area: 92,2 m²

Windows and doors:

Door: 2 single 50% glass 1,98x0,85 m and 3 single full wood 1,98x0,85 m
 Window: 1 single 0,52x0,5 m, 1 single 0,92x0,7 m and 6 double 0,92x1,3 m
 Threshold: covered with steel

Installation kit:

*See optional products pages 91

Optional products

For summer house/chalet

Wall	Name	Article No.	Dipping (pine colour)	Bitumen roof tiles	Underlayer	Metal roof cover	Rain gutters	Quality of windows and doors	Insulation
20-40 m ²	44 Alma 7,05x8	S26197	●	● 66m ²	● 68m'	●	●	P+, HQ*, PVC*	Walls/roof/floor
	44 Louise 6x6	S26777	●	● 54m ²	● 55m'	●	●	P+, HQ*, PVC*	Walls/roof/floor
	68 Lukas 6,5x7,7	S26241	●	● 63m ²	● 58m'	●	●	P+, HQ*, PVC*	Walls/roof/floor
	68 Veronica 5x6	S26266	●	● 39m ²	● 39m'	●	●	P+, HQ*, PVC*	Walls/roof/floor
20-40 m ²	68 Almeria 6x8,87	S26198	●	● 63m ²	● 66m'	●	●	P+, HQ*, PVC*	Walls/roof/floor
	44 Gustav A 6x6	S26226	●	● 66m ²	● 66m'	●	●	P+, HQ*, PVC*	Walls/roof/floor
	68 Gustav A 6x6 WC	S26227	●	● 66m ²	● 66m'	●	●	P+, HQ*, PVC*	Walls/roof/floor
	44 Gustav B 6x8	S29362	●	● 66m ²	● 66m'	●	●	P+, HQ*, PVC*	Walls/roof/floor
	68 Gustav B 6x8 WC	S29363	●	● 66m ²	● 66m'	●	●	P+, HQ*, PVC*	Walls/roof/floor
40-60 m ²	44 Gustav B 6x8	S26262	●	● 81m ²	● 83m'	●	●	P+, HQ*, PVC*	Walls/roof/floor
	68 Gustav B 6x8 WC	S26226	●	● 81m ²	● 83m'	●	●	P+, HQ*, PVC*	Walls/roof/floor
	44 Gustav B 6x8 WC	S29364	●	● 81m ²	● 83m'	●	●	P+, HQ*, PVC*	Walls/roof/floor
	68 Gustav B 6x8 WC	S29365	●	● 81m ²	● 83m'	●	●	P+, HQ*, PVC*	Walls/roof/floor
	68 Iberica T2 6,36x8,86	S26231	●	● 72m ²	● 69m'	●	●	P+, HQ*, PVC*	Walls/roof/floor
	68 Maja 7,4x10	S26243	●	● 93m ²	● 92m'	●	●	P+, HQ*, PVC*	Walls/roof/floor
	68 Max 5,6x6,6	S26246	●	● 69m ²	● 67m'	●	●	P+, HQ*, PVC*	Walls/roof/floor
	68 Olga 8x9	S27471	●	● 90m ²	● 90m'	●	●	P+, HQ*, PVC*	Walls/roof/floor
	68 Scarlett 7x10,2	S26259	●	● 84m ²	● 88m'	●	●	P+, HQ*, PVC*	Walls/roof/floor
	68 Iberica T3 7,92x11,84	S26230	●	● 111m ²	● 113m'	●	●	P+, HQ*, PVC*	Walls/roof/floor
60+ m ²	68 Jennifer 10,5x8,52	S26205	●	● 102m ²	● 109m'	●	●	P+, HQ*, PVC*	Walls/roof/floor
	68 Markus 7,1x11,1	S26245	●	● 102m ²	● 102m'	●	●	P+, HQ*, PVC*	Walls/roof/floor



*Note: HQ or PVC windows&doors quality option for 44mm wall thickness is available if wall insulation is included.

Country house/villa



1 story



2 story

1 story p.94-103



Arica 7x10

p.94



Granada 8,8x14

p.95



Leon 9,4x10,7

p.96



Orchidea 6x11,5

p.97



Oskar 8,87x10,04

p.98



Sevilla 7,8x13,74

p.99



Takoma 12x8

p.100



Vienna 8,3x11

p.101



Wendy 9,7x9,8

p.102



Winnipeg 10,01x16,69

p.103

2 story p.104-111



Athena 5,86x11,16

p.104



Felix 6x10

p.105



Nagano 10,14x8,04

p.106



Porto 9,2x13,2

p.107



Salvador 8x11,19

p.108



Sweden 7,5x13,5

p.109



Talinn 5x10

p.110



Verona 5,93x8,75

p.111

Arica 7x10

Article No. S26883

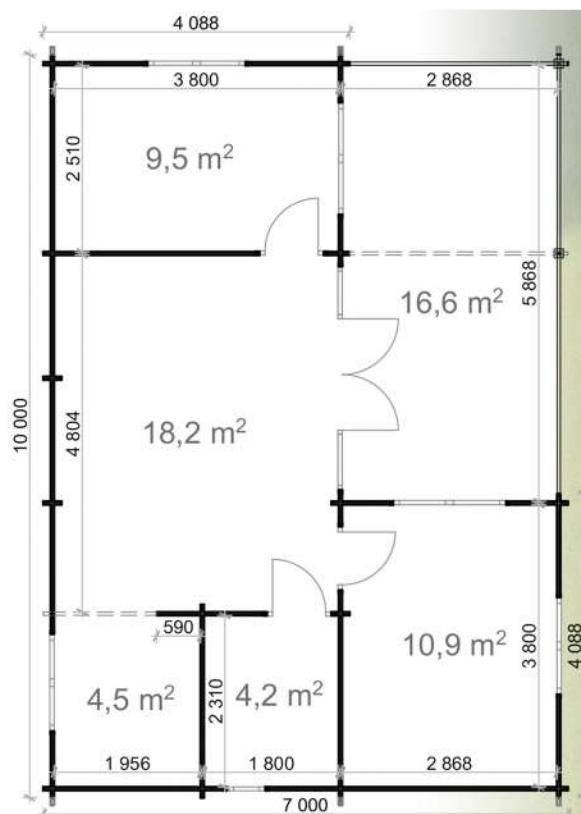
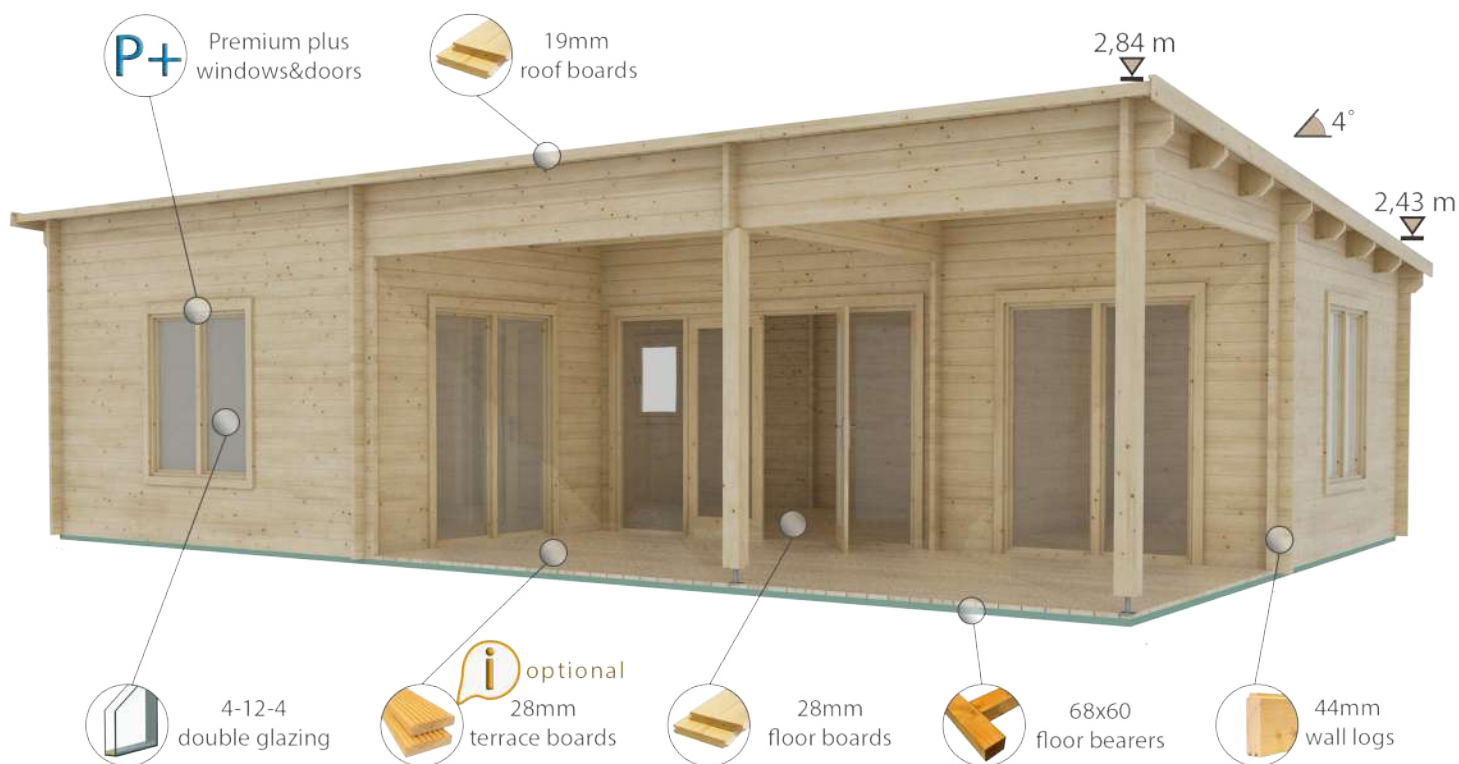

Project specification:

External measures: 7x10 m
 Base footprint: 6,8x9,8 m
 Internal house area: 47,4 m²
 Terrace: 16,6 m²
 External wall area: 74 m²
 Roof area: 70,2 m²

Windows and doors:

Door: 1 quadruple 100% glass 1,98x3 m and 3 single full wood 1,98x0,85 m
 Window: 1 single 0,52x0,5 m, 1 double 0,92x1,3 m, 2 double 1,43x1,3 m and 2 double 1,98x1,5 m
 Threshold: covered with steel

Installation kit:

*See optional products page 112

Granada 8,8x14

Article No. S26890

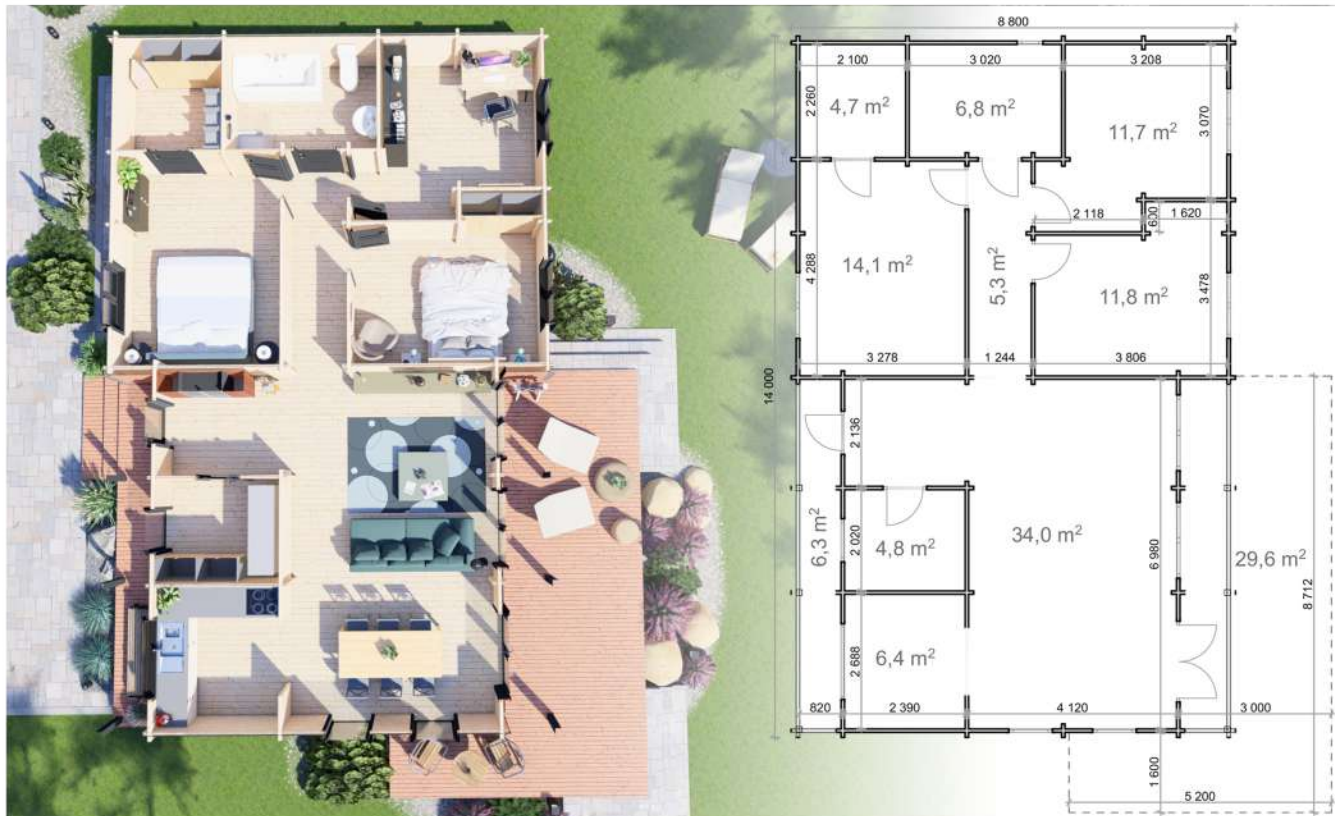
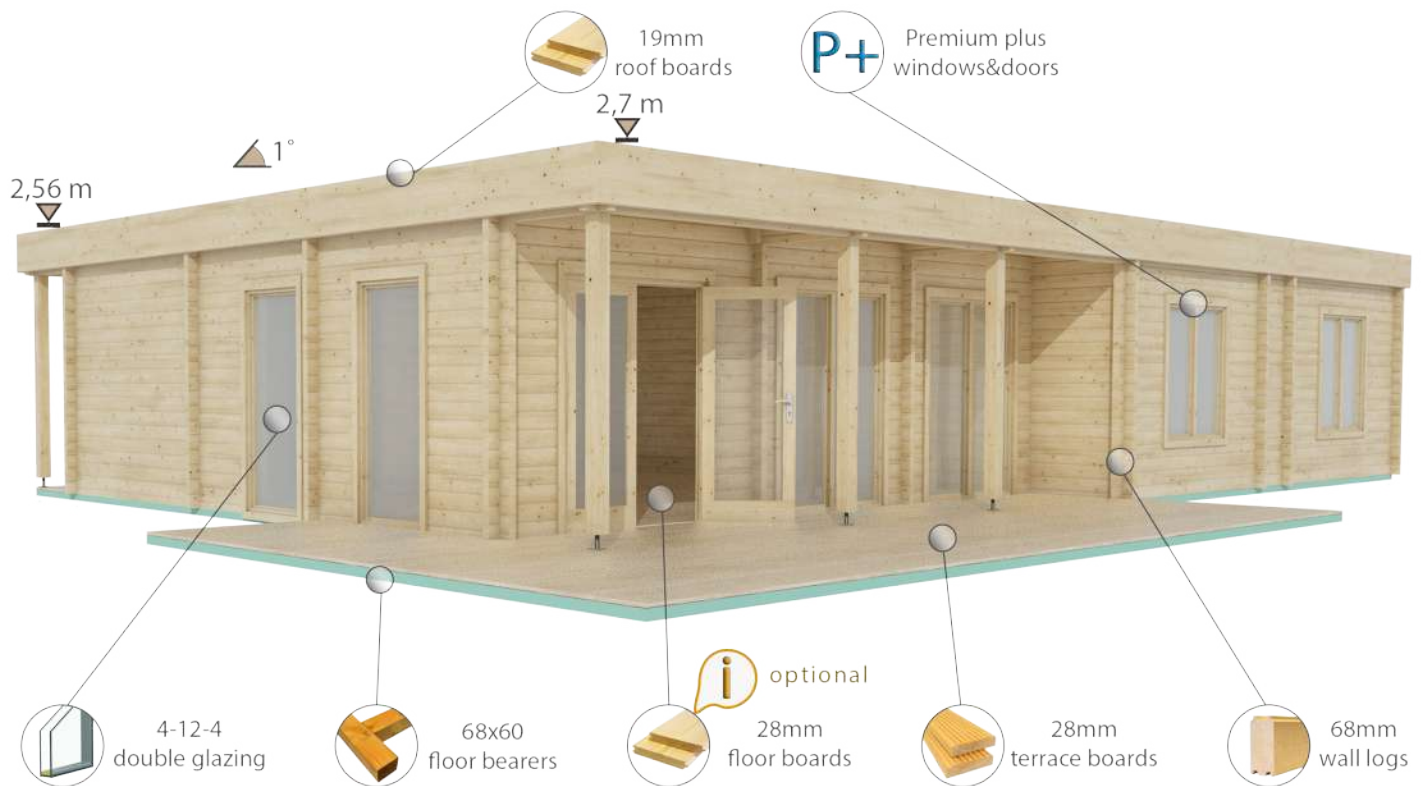

Project specification:

External measures: 8,8x14 m
 Base footprint: 8,6(+2)x13,8(+1,6) m
 Internal house area: 99,5 m²
 Terrace area: 35,9 m²
 External wall area: 100 m²
 Roof area: 123,2 m²

Windows and doors:

Door: 1 double 100% glass 1,98x1,6 m,
 1 single 100% glass 1,98x0,5 m and 6
 single full wood 1,98x0,85 m
 Window: 1 single 0,52x0,5 m, 1 single
 0,39x1,5 m, 3 single 1,98x0,85 m, 3 double
 1,43x1,3 m and 2 double 1,98x1,5 m

Threshold: covered with steel

Installation kit:

*See optional products page 112

Leon 9,4x10,7

Article No. S26887

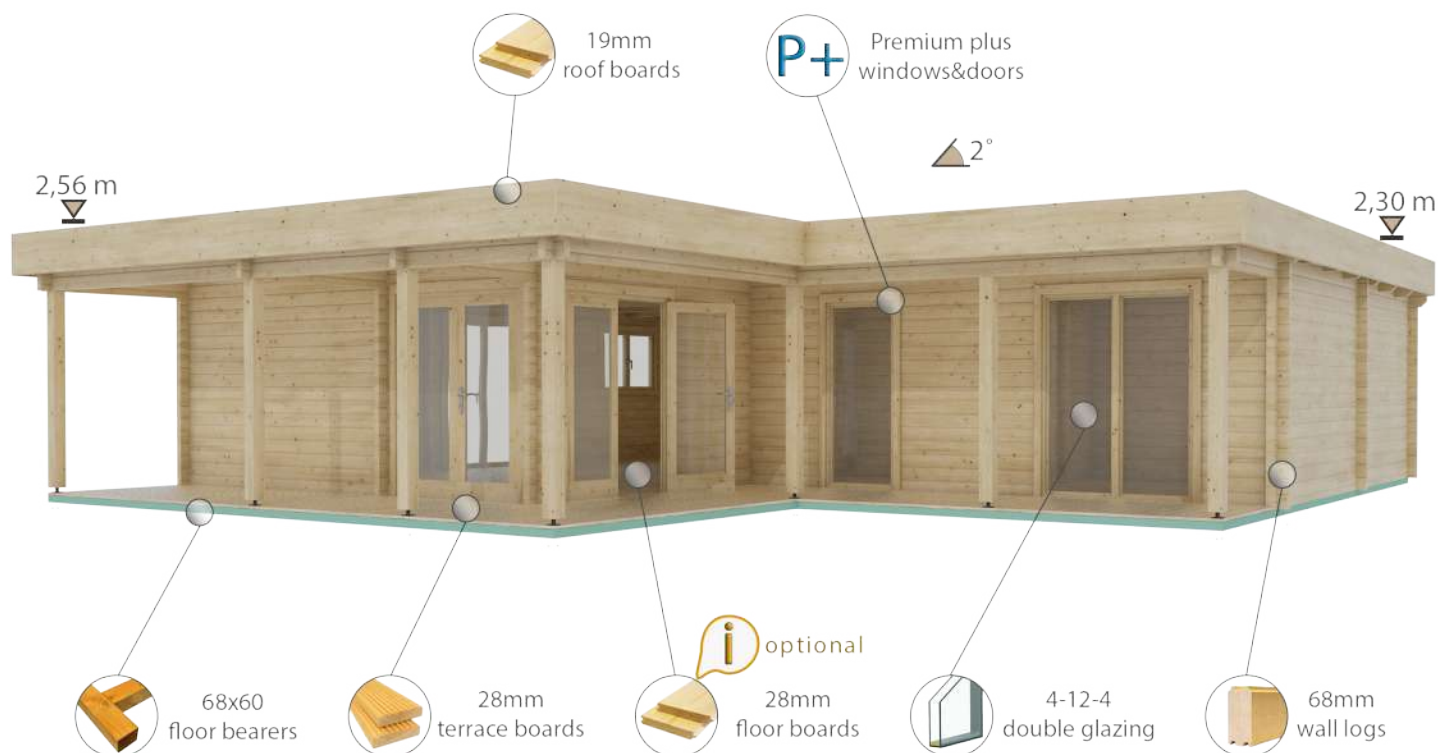

Project specification:

External measures: 9,4x10,7 m

Base footprint: 9,2(+1,56)x10,5 m

Internal house area: 74 m²

Terrace: 20,6 m²

External wall area: 81 m²

Roof area: 109,5 m²

Windows and doors:

Door: 2 double 100% glass 1,98x1,6 m and 3 single full wood 1,98x0,85 m

Window: 1 single 1,98x0,5 m, 2 single 1,98x0,85 m, 2 double 0,92x1,3 m and 2 double 1,98x1,5 m

Threshold: covered with steel

Installation kit:

*See optional products page 112

Orchidea 6x11,5

Article No. S26871

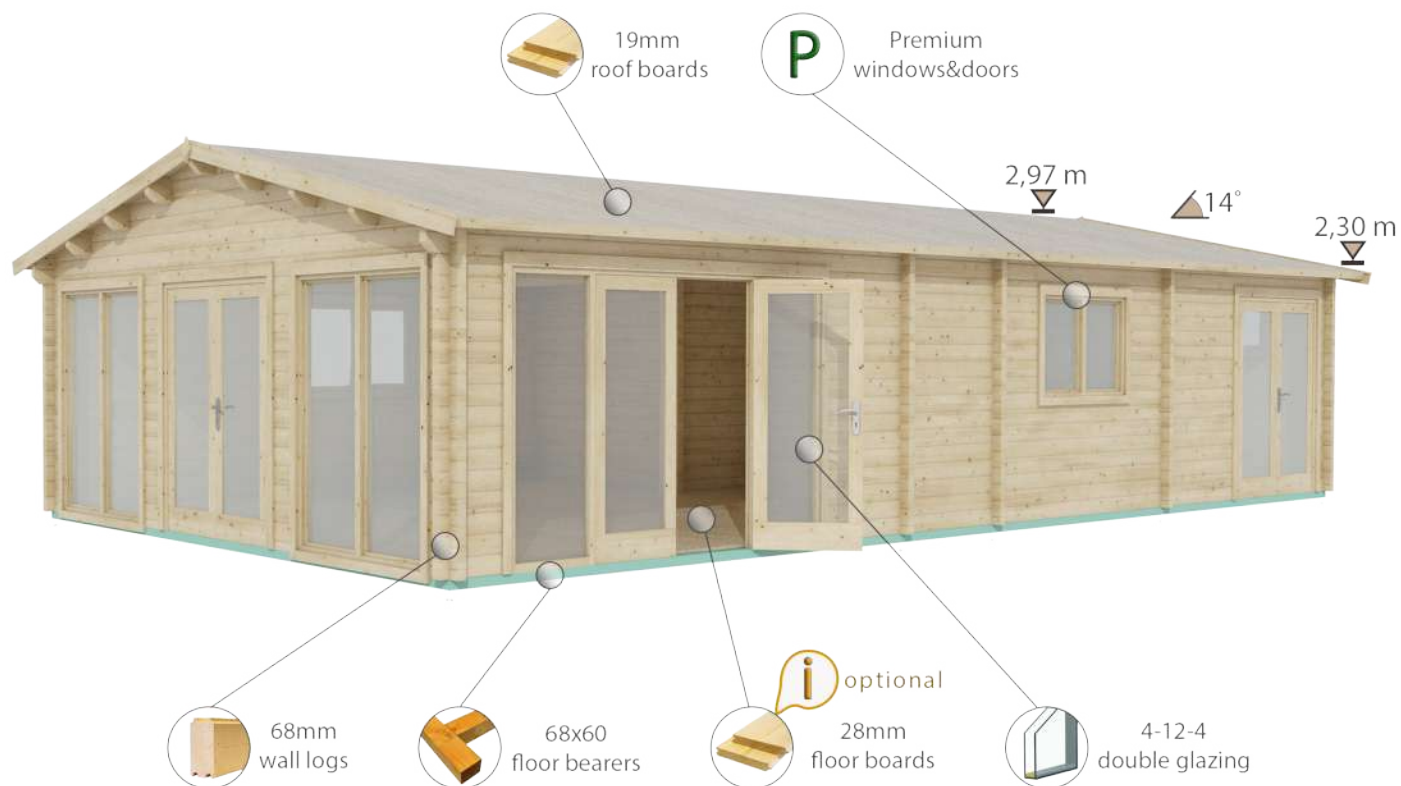

Project specification:

External measures: 5,96x11,46 m

Base footprint: 5,8x11,3 m

Internal house area: 61,9 m²

External wall area: 64 m²

Roof area: 76,8 m²

Windows and doors:

Door: 1 quadruple 100% glass 1,98x3 m, 2 double 100% glass 1,98x1,6m and 4 single full wood 1,98x0,85 m

Window: 4 single 0,52x0,5 m, 1 single 0,92x0,7 m, 2 double 0,92x1,3 m and 2 double 1,98x1,5 m

Threshold: covered with steel

Installation kit:

*See optional products page 112

Oskar 8,87x10,04

Article No. S27475

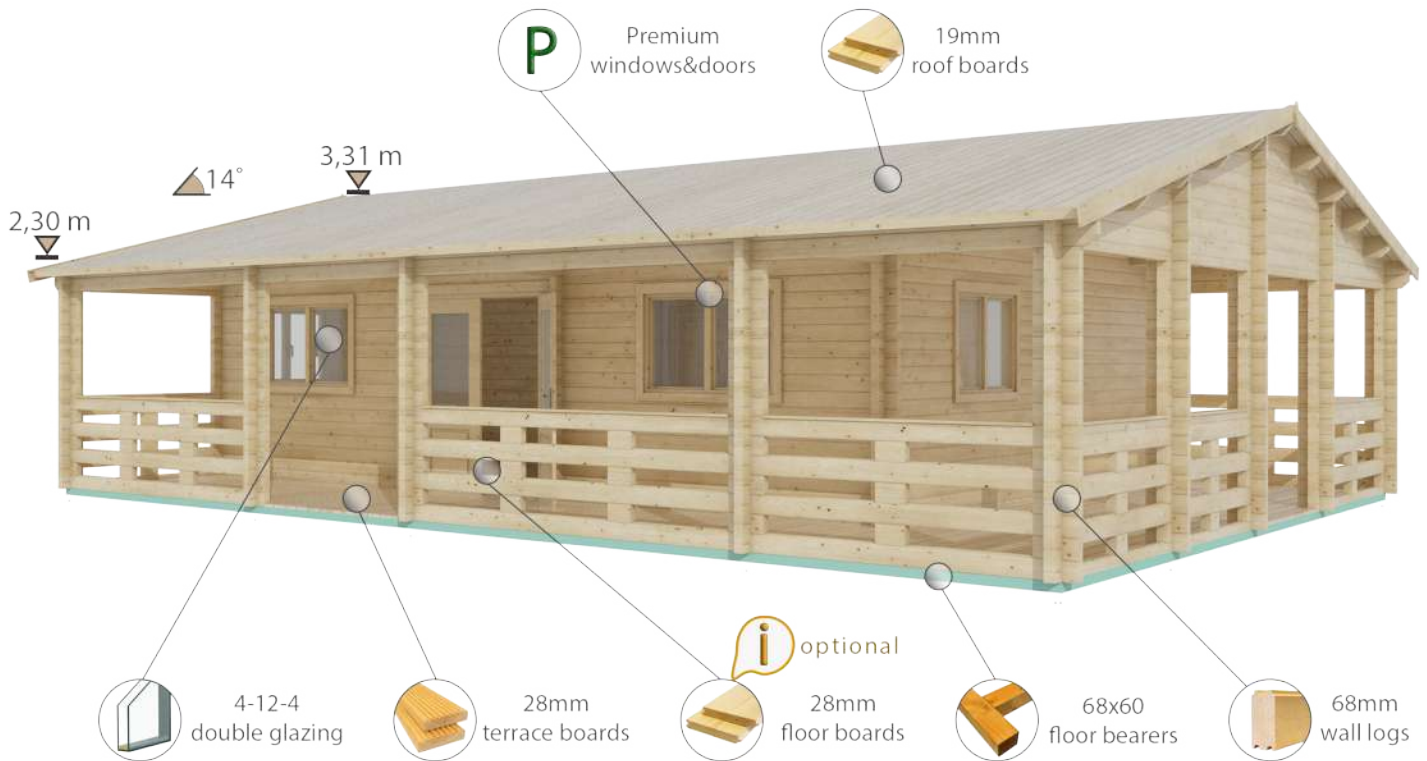

Project specification:

External measures: 8,87x10,04 m
 Base footprint: 8,67x9,84 m
 Internal house area: 48,4 m²
 Terrace: 32,5 m²
 External wall area: 68 m²
 Roof area: 96,5 m²

Windows and doors:

Door: 1 double 100% glass 1,98x1,6 m
 and 3 single full wood 1,98x0,85 m
 Window: 3 single 0,92x0,7 m and 5
 double 0,92x1,3 m
 Threshold: covered with steel

Installation kit:

*See optional products page 112

Sevilla 7,8x13,74

Article No. S26260

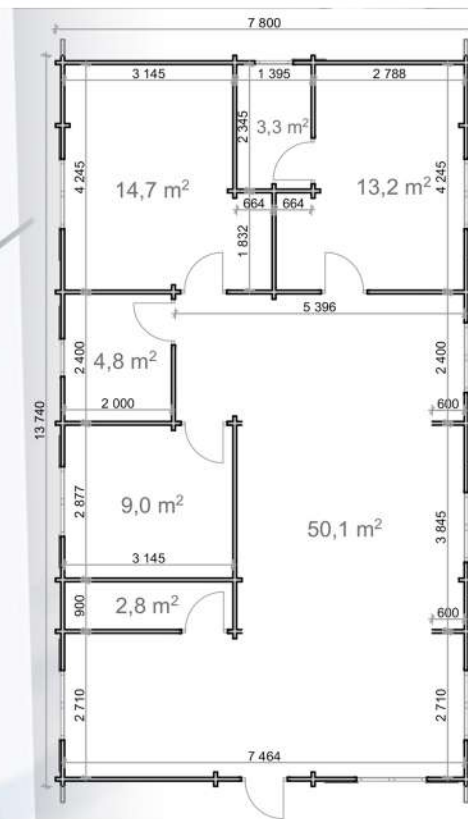
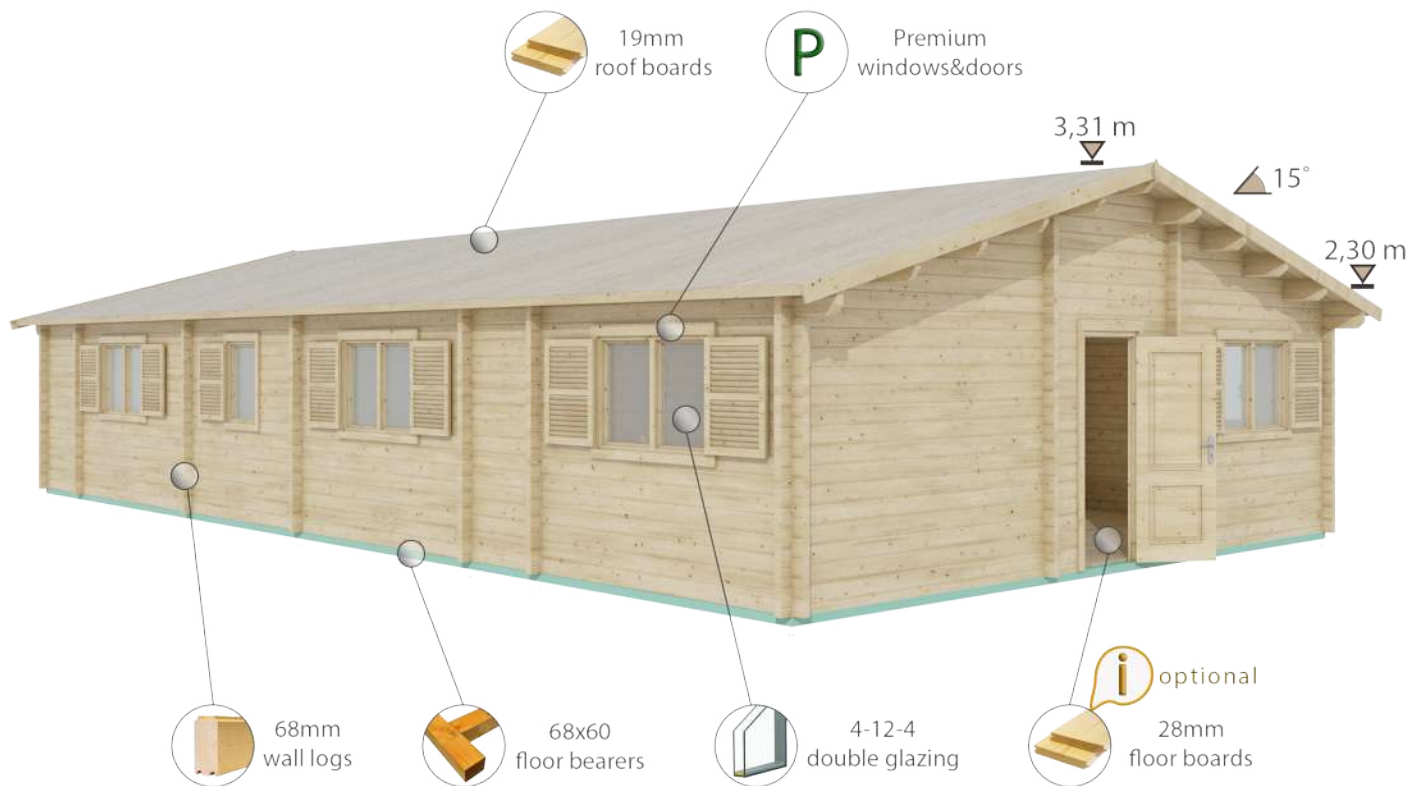

Project specification:

External measures: 7,8x13,74 m
 Base footprint: 7,6x13,54 m
 Internal house area: 97,8 m²
 External wall area: 95 m²
 Roof area: 120,4 m²

Windows and doors:

Door: 7 single full wood 1,98x0,85 m
 Window: 2 single 0,92x0,7 m and 8 double 0,92x1,3 m
 Threshold: covered with steel

Installation kit:

Shutters kit:

*See optional products page 112

Takoma 12x8

Article No. S26884

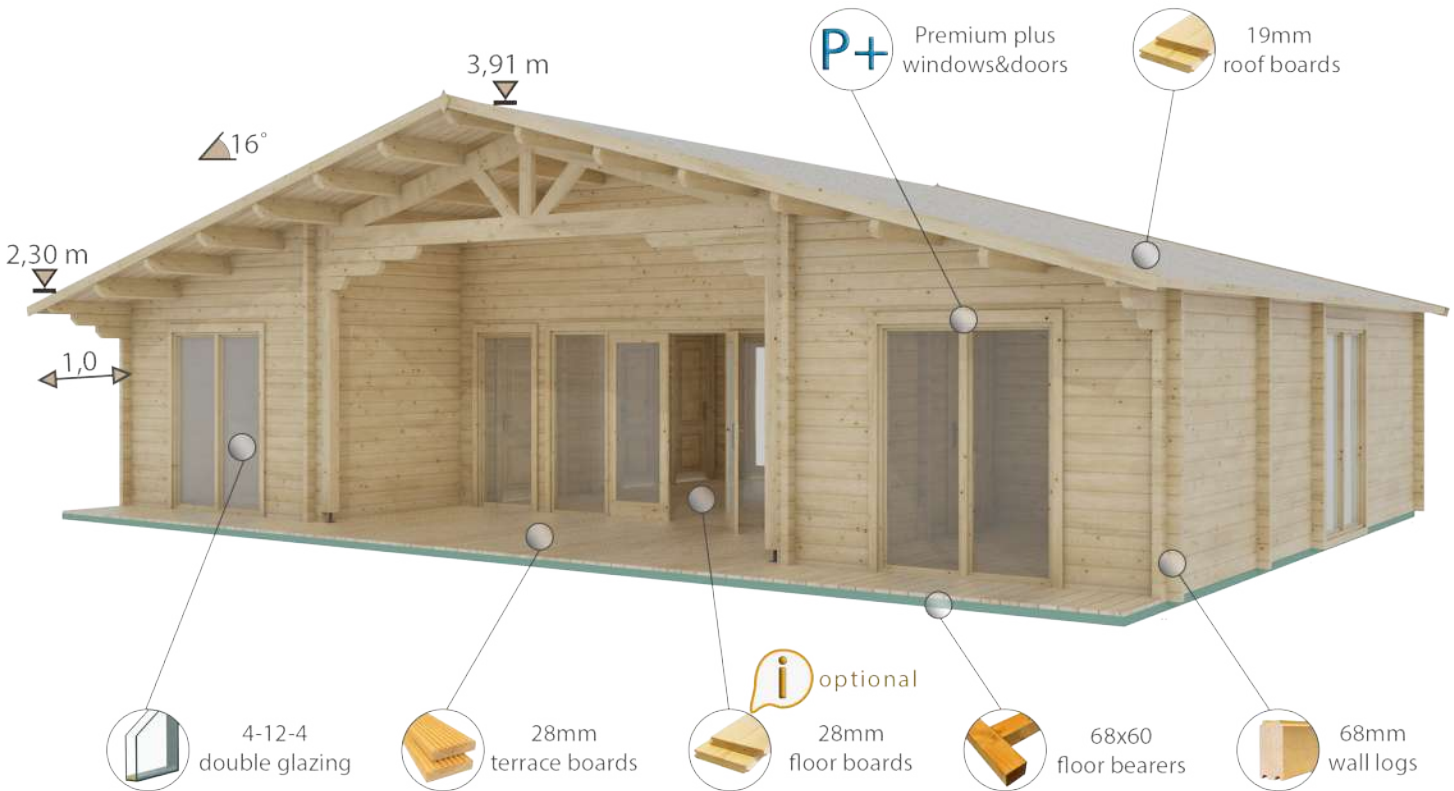

Project specification:

External measures: 12,02x8,02 m
 Base footprint: 11,82x7,82(+0,8) m
 Internal house area: 75,1 m²
 Terrace: 22,3 m²
 External wall area: 116 m²
 Roof area: 115,3 m²

Windows and doors:

Door: 1 quadruple 100% glass 1,98x3 m, 1 single 100% glass 1,98x0,85 m and 5 single full wood 1,98x0,85 m
 Window: 1 single 0,52x0,5 m, 1 single 1,98x0,5 m, 3 single 1,98x0,85 m and 3 double 1,98x1,5 m

Threshold: covered with steel

Installation kit:

*See optional products page 112

Vienna 8,3x11

Article No. S26267

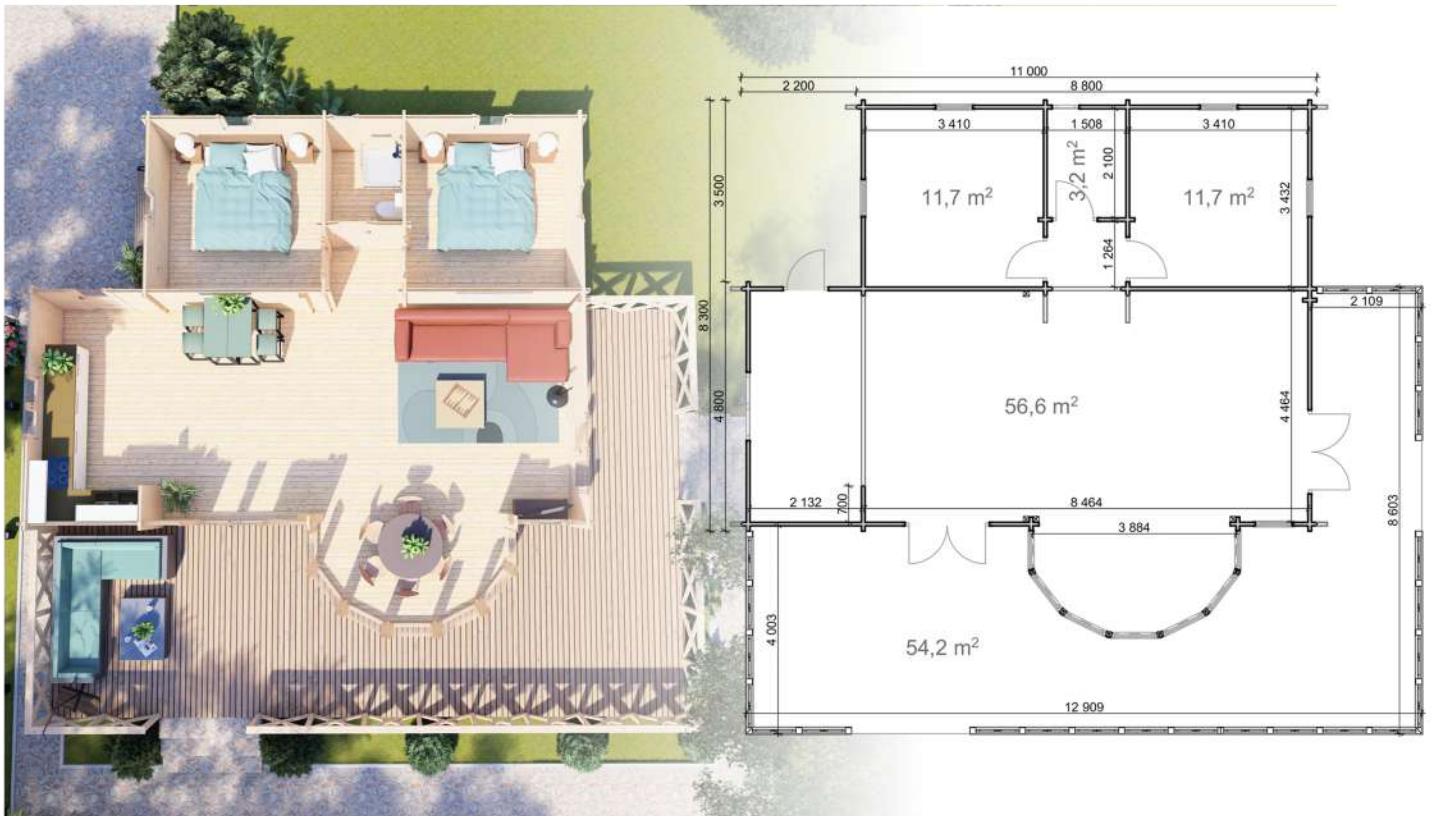
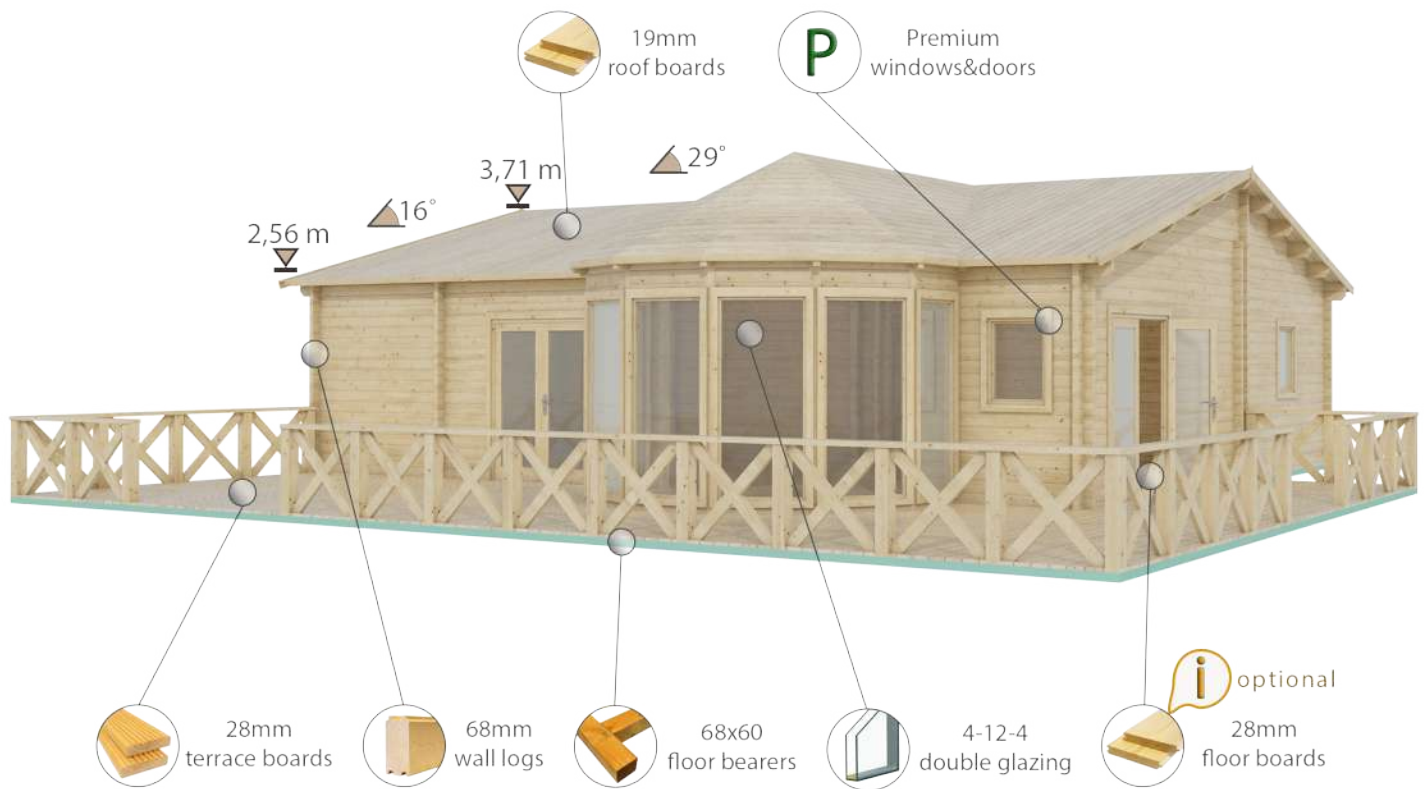

Project specification:

External measures: 8,3x11 m

Base footprint: 8,1(+3,9)x10,8(+2) m

Internal house area: 83 m²

Terrace area: 54,2 m²

External wall area: 96 m²

Roof area: 103,9 m²

Windows and doors:

Door: 2 double 100% glass 1,98x1,6 m,
1 single 50% glass 1,98x0,85 m and 3
single full wood 1,98x0,85 m

Window: 1 single 0,52x0,5 m, 5 single
0,92x0,7 m, 2 single 1,98x0,74 m, 5 single
1,98x0,885 and 1 double 0,92x1,3 m

Threshold: covered with steel

Installation kit:

*See optional products page 112

Wendy 9,7x9,8

Article No. S26268

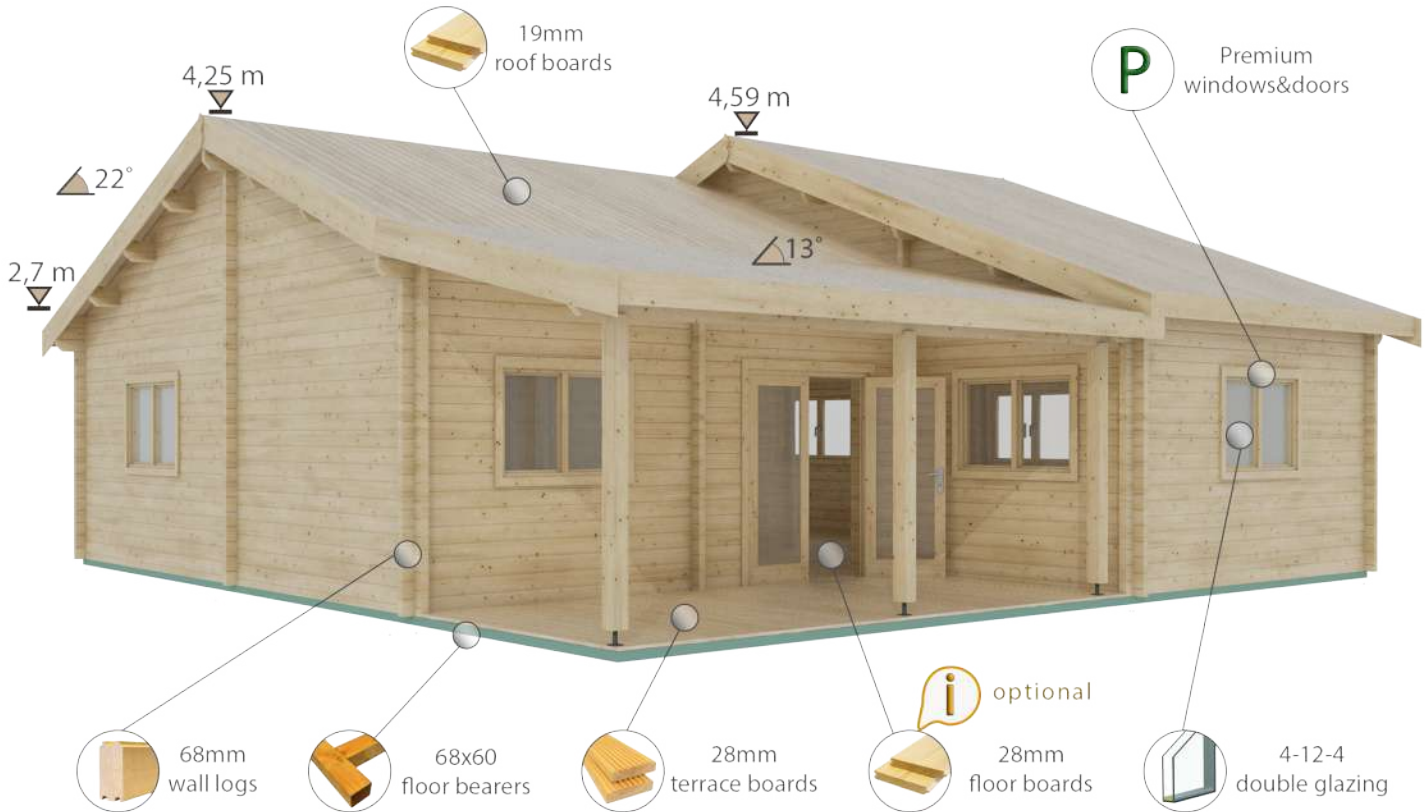

Project specification:

External measures: 9,7x9,8 m
 Base footprint: 9,5x9,6 m
 Internal house area: 72,9 m²
 Terrace: 13,7 m²
 External wall area: 115 m²
 Roof area: 112,2 m²

Windows and doors:

Door: 1 double 100% glass 1,98x1,6 m, 1 single 100% glass 1,98x0,85 m and 4 single full wood 1,98x0,85 m
 Window: 1 single 0,52x0,5 m and 7 double 0,92x1,3 m
 Threshold: covered with steel

Installation kit:

*See optional products page 112

Winnipeg 10,01x16,69

Article No. S26882

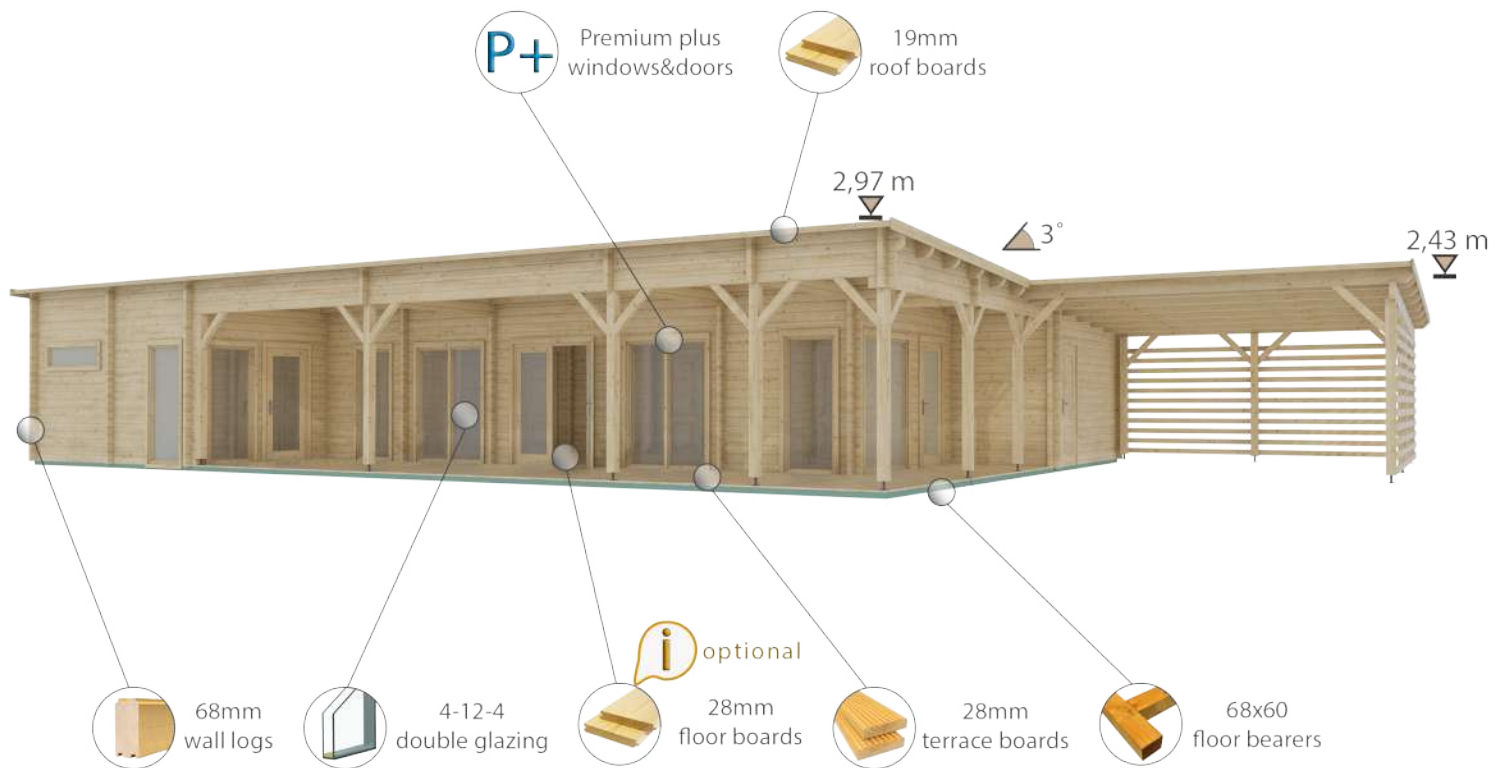

Project specification:

External measures: 10,01x16,69 m
 Base footprint: 9,81x16,49 m
 Internal house area: 118,2 m²
 Terrace area: 37,1 m²+25,6m² (canopy)
 External wall area: 107 m²
 Roof area: 202,9 m²

Windows and doors:

Door: 1 double 100% glass 1,98x1,6 m,
 2 single 100% glass 1,98x0,85 m and
 9 single full wood 1,98x0,85 m
 Window: 2 single 0,52x0,5 m, 1 single
 0,39x0,7 m, 1 single 0,39x1,5 m, 6 single
 1,98x0,85 and 4 double 1,98x1,5 m

Threshold: covered with steel

Installation kit:

*See optional products page 112

Athena 5,86x11,16

Article No. S26860

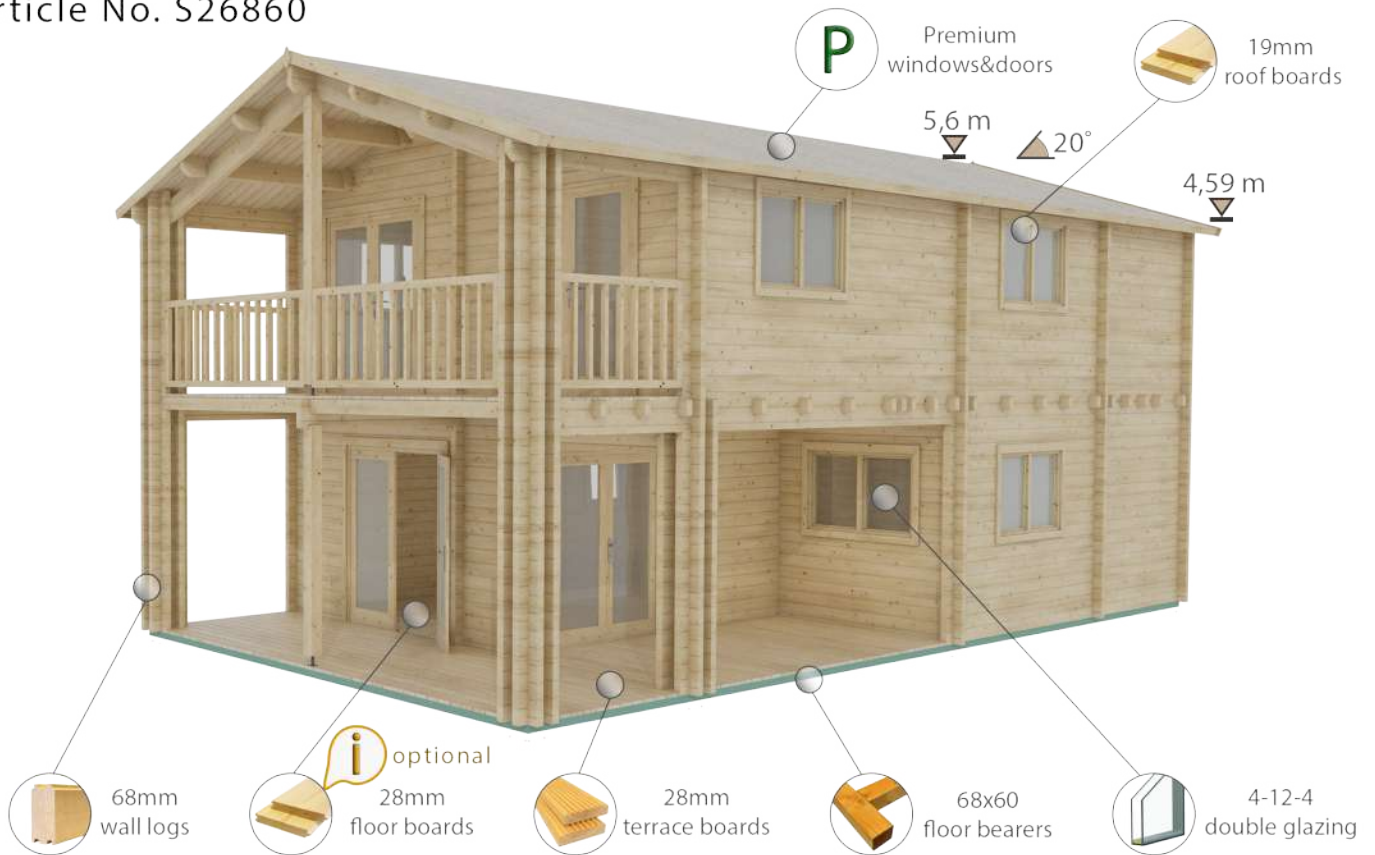

Project specification:

External measures: 5,858x11,16 m
 Base footprint: 5,658x10,96 m
 Internal house area: 86,1 m²
 Terrace: 19,3 m² + 10,7 m² (balcony)
 External wall area: 127 m²
 Roof area: 74,5 m²

Windows and doors:

Door: 4 double 100% glass 1,98x1,6 m, 1 single 50% glass 1,98x0,85 m and 6 single full wood 1,98x0,85 m
Window: 4 single 0,92x0,7 m and 7 double 0,92x1,3 m
Threshold: covered with steel

Installation kit:

*See optional products page 112

Felix 6x10

Article No. S26218

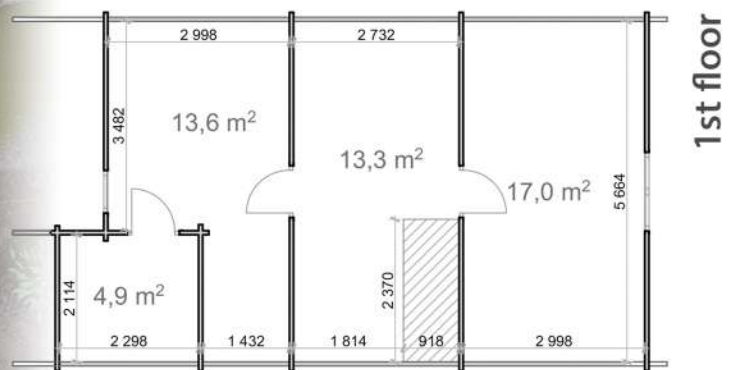
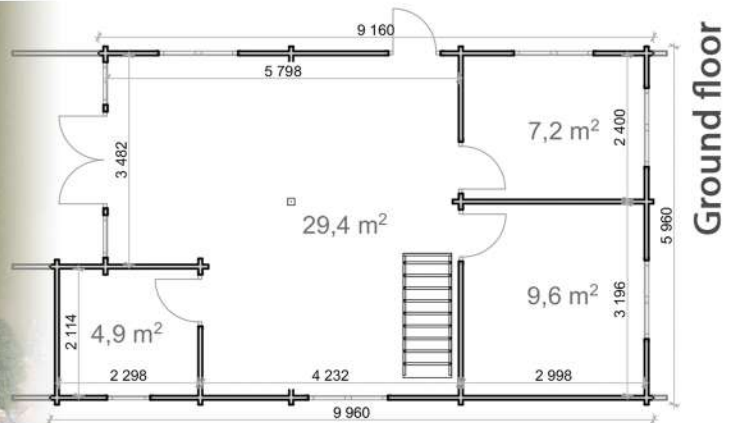
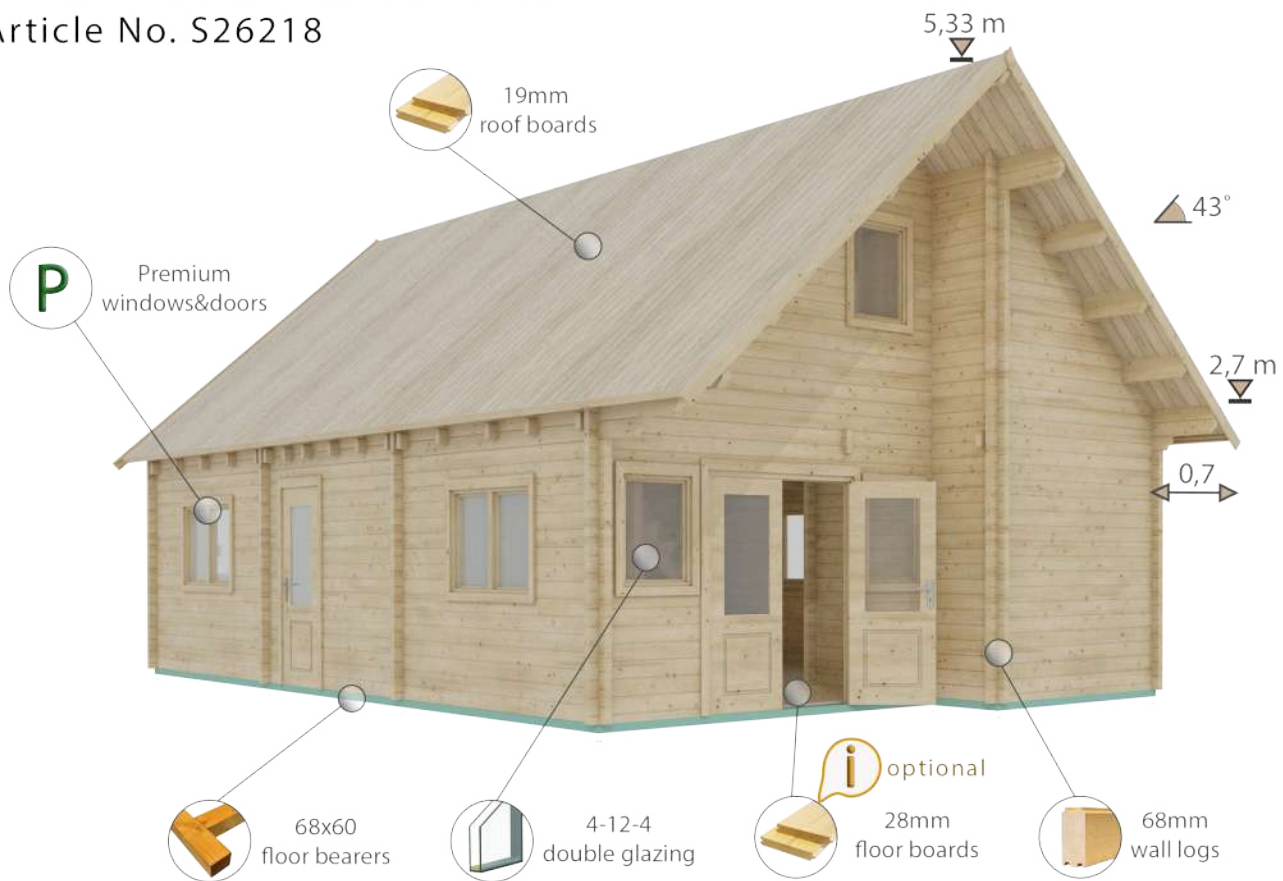

Project specification:

External measures: 5,96x9,96 m
 Base footprint: 5,8x9(+0,8) m
 Internal house area: 99,9 m²
 External wall area: 92 m²
 Roof area: 92,9 m²

Windows and doors:

Door: 1 double 50% glass 1,98x1,6 m,
 1 single 50% glass 1,98x0,85 m and 6
 single full wood 1,98x0,85 m
Window: 4 single 0,92x0,7 m and 6
 double 0,92x1,3 m
Threshold: covered with steel

Installation kit:

Stair (straight):

*See optional products page 112

Nagano 10,14x8,04

Article No. S29344

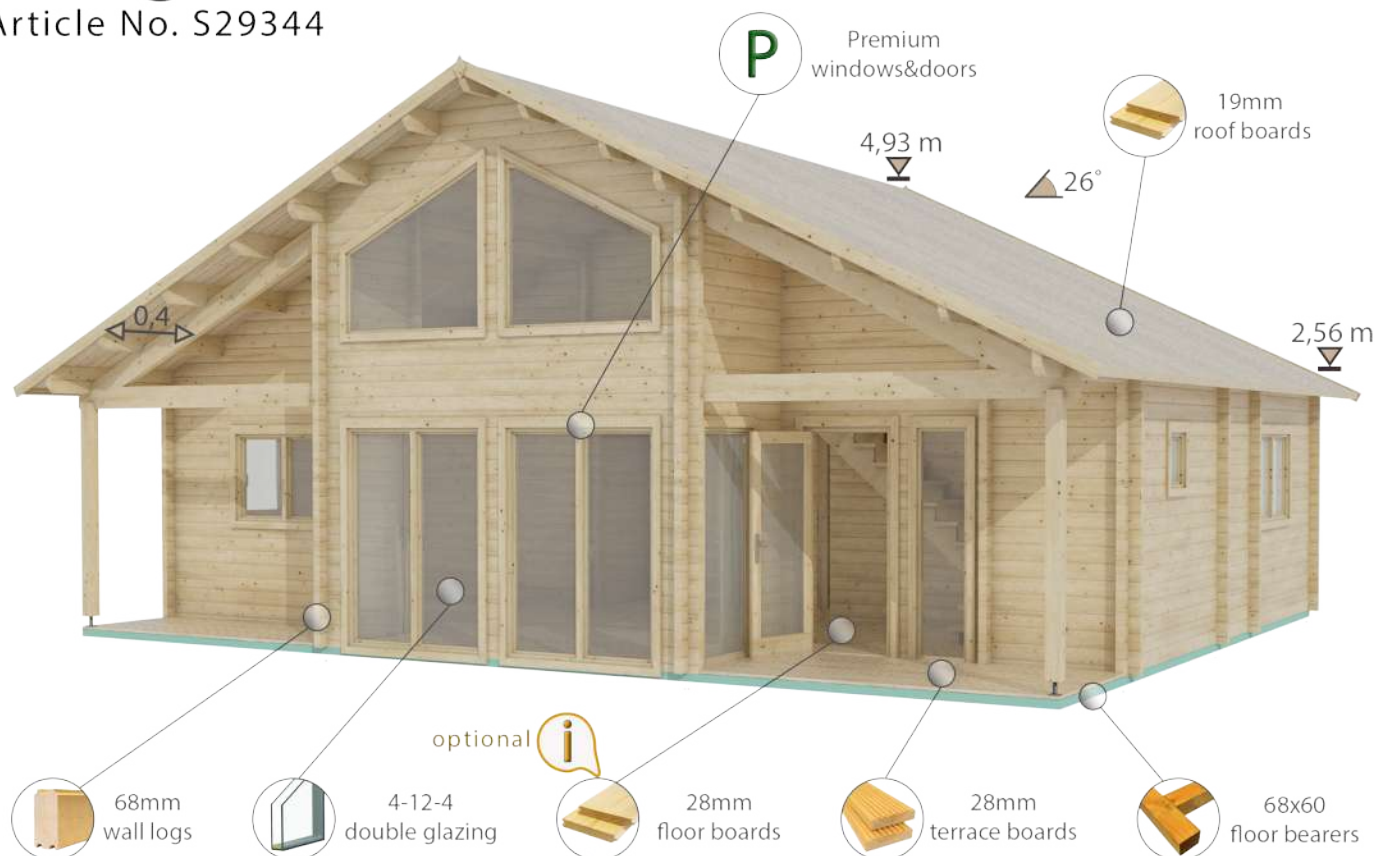

Ground floor

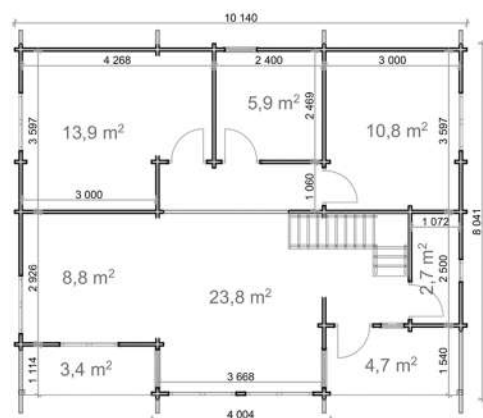

1st floor

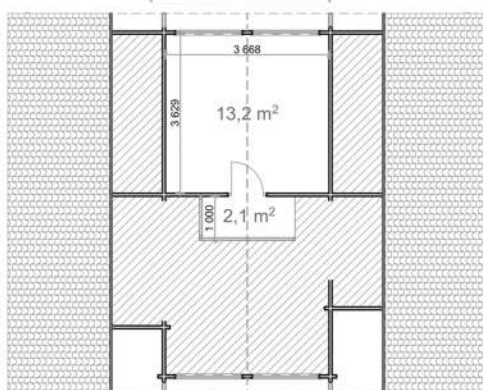

Country house/villa
2 story

104-111

Project specification:

External measures: 10,14x8,041 m
 Base footprint: 9,94x7,841 m
 Internal house area: 81,2 m²
 Terrace: 8,1 m²
 External wall area: 129 m²
 Roof area: 103 m²

Windows and doors:

Door: 1 single 100% glass 1,98x0,85 m and 5 single full wood 1,98x0,85 m
 Window: 1 single 0,52x0,5 m, 1 single 1,98x0,5 m, 1 single 0,92x0,7 m, 2 single 1,98x0,85 m, 4 double 0,92x1,3 m, 2 double 1,98x1,5 m and 4 trapezoid 1,47x1,5 m

Threshold: covered with steel

Installation kit:
 Stair (L-shape):

*See optional products page 112

Porto 9,2x13,2

Article No. S26281

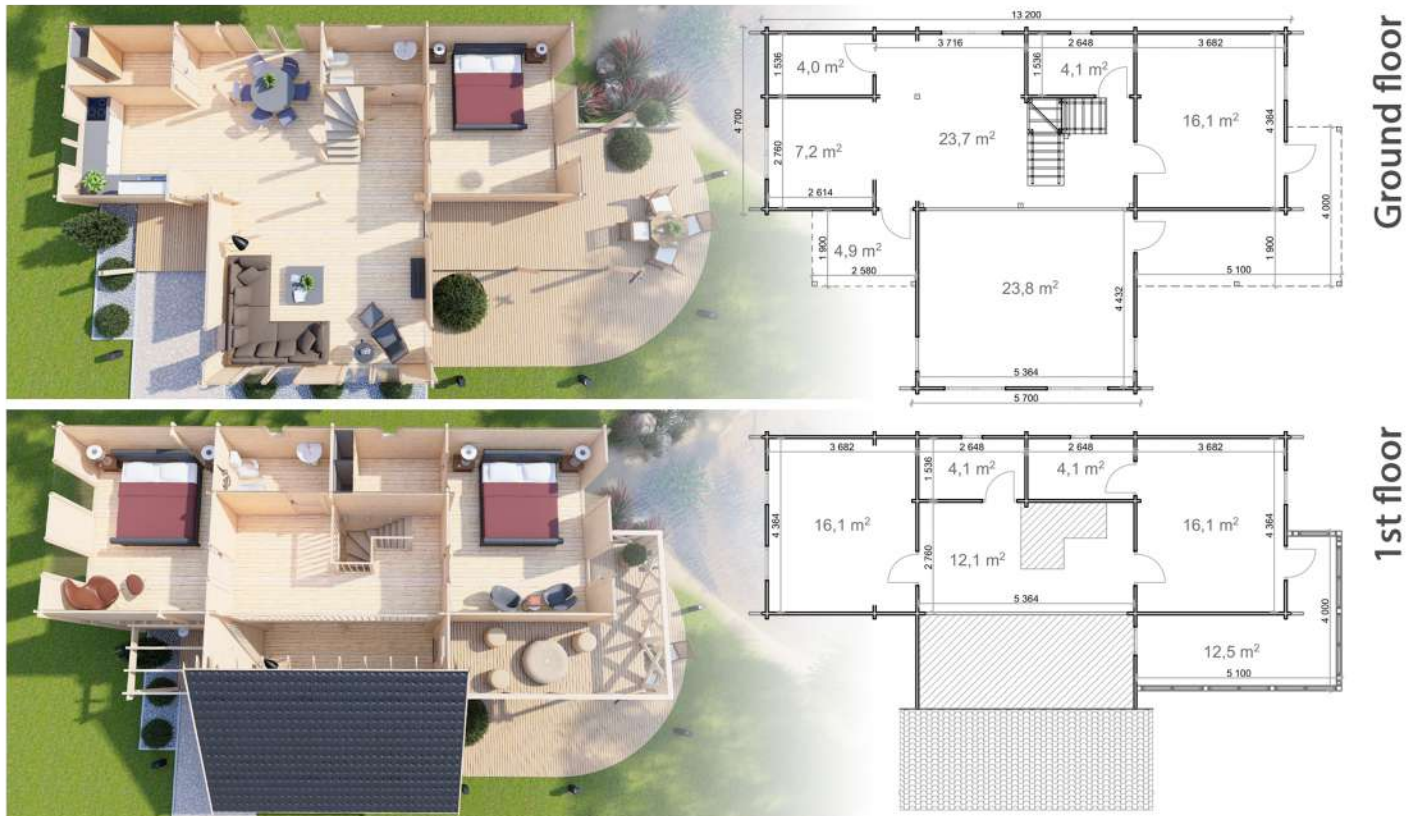
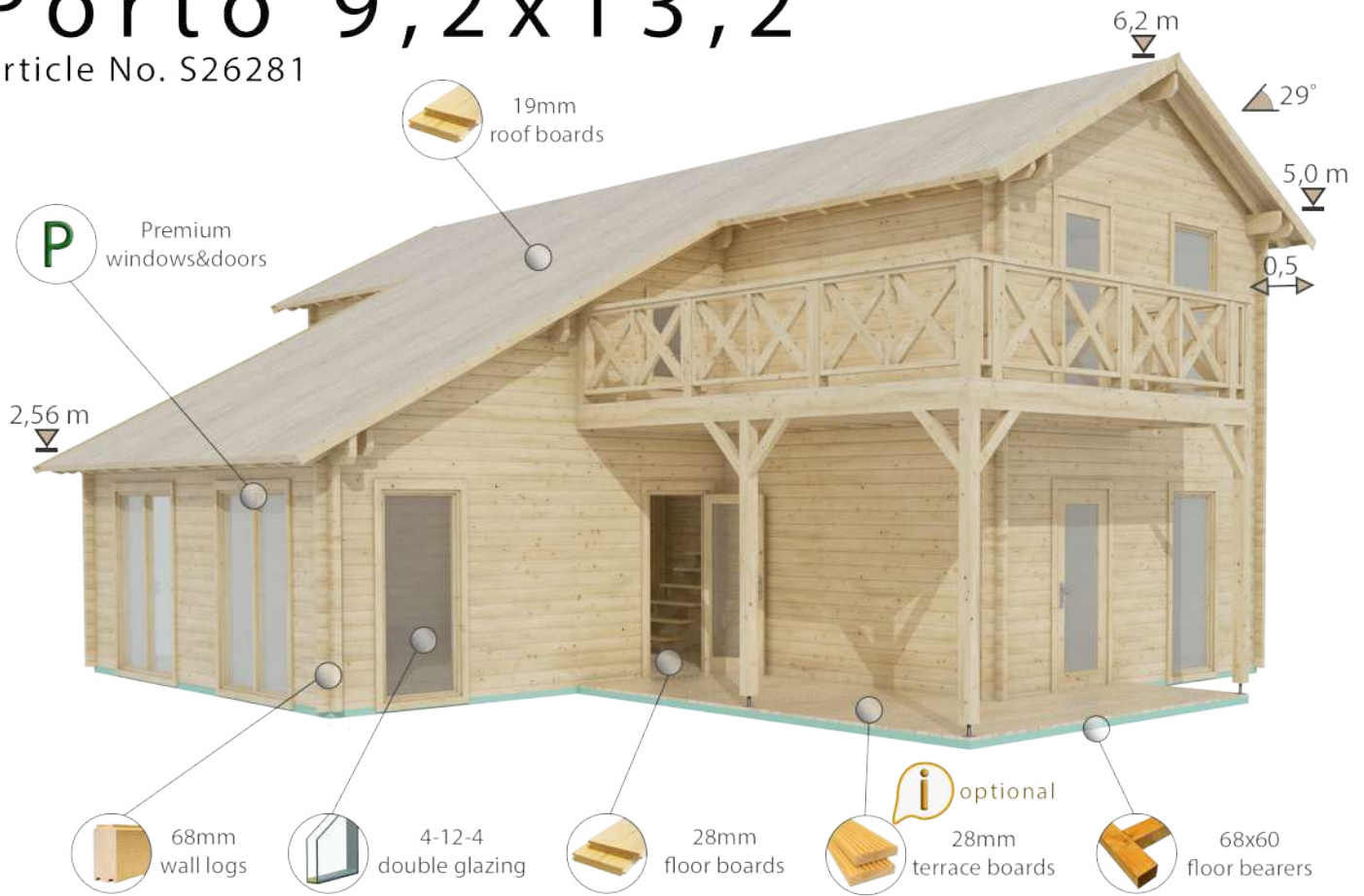

Project specification:

External measures: 9,2x13,2 m
 Base footprint: 4,5(+4,5)x13,2(+1,25)m
 Internal house area: 132,4 m²
 Terrace : 29,9 m² + 12,6 m² (balcony)
 External wall area: 178 m²
 Roof area: 116,7 m²

Windows and doors:

Door: 3 single 100% glass 1,98x0,85 m,
 1 single 50% glass 1,98x0,85 m and 7
 single full wood 1,98x0,85 m
 Window: 3 single 0,52x0,5 m, 1 single
 0,92x0,7 m, 6 single 1,98x0,85 m, 1 double
 0,92x1,3 m and and 3 double 1,98x1,5 m

Threshold: covered with steel

Installation kit:
 Stair (L-shape):

*See optional products page 112

Salvador 8x11,19

Article No. S26282

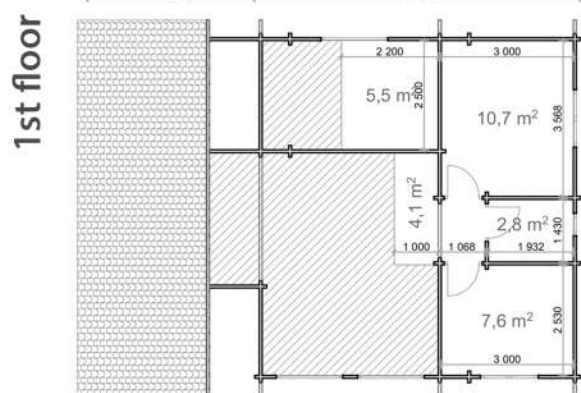
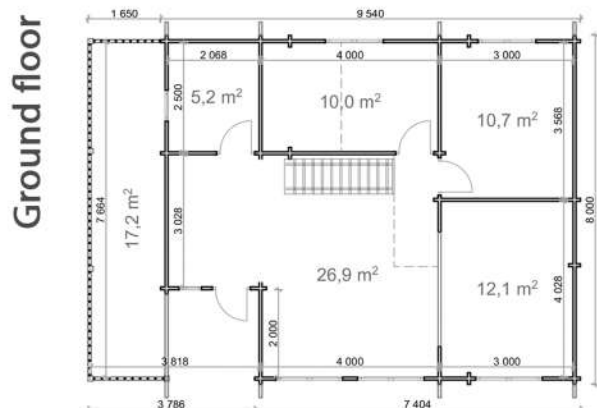
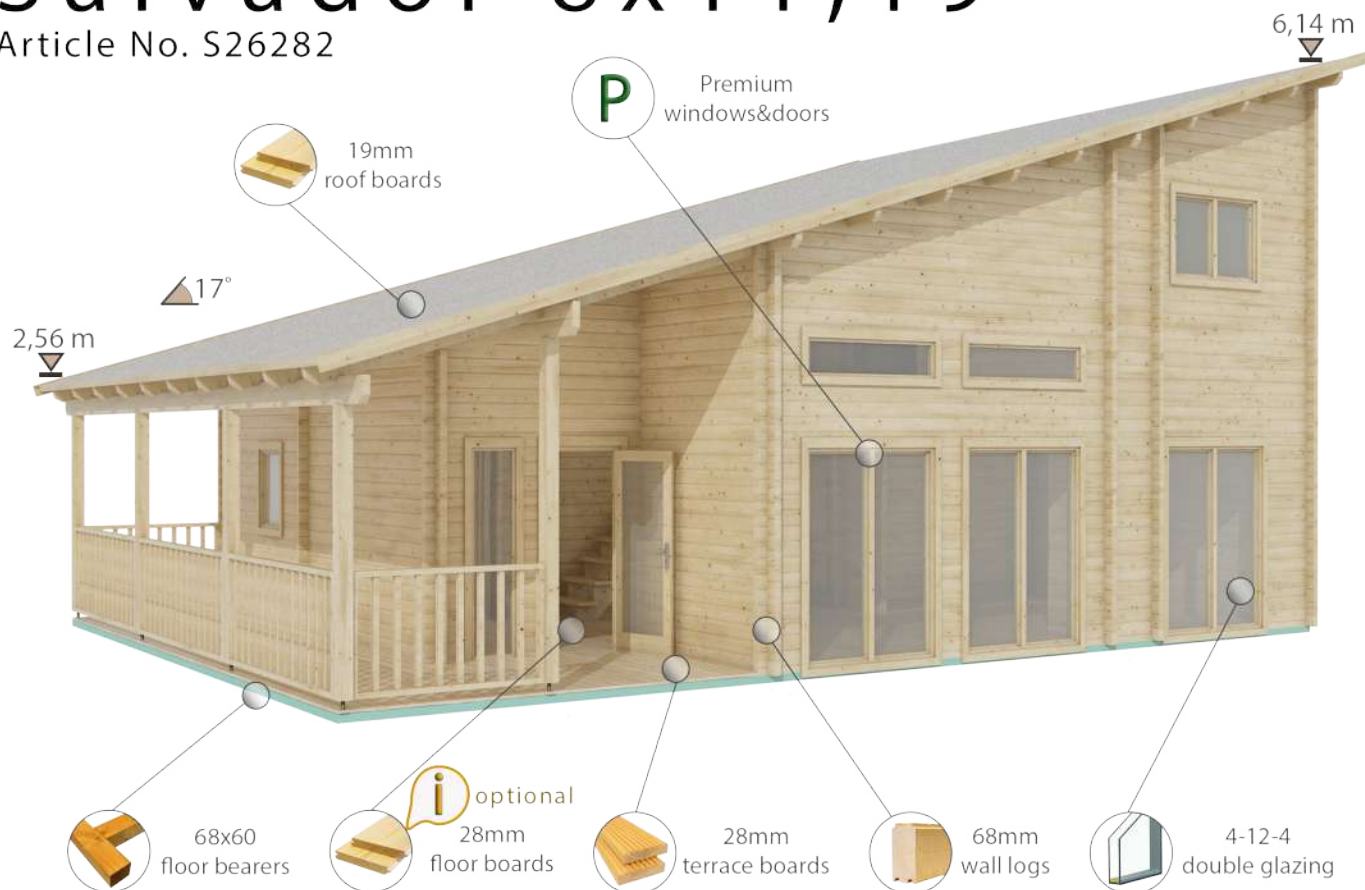

Project specification:

External measures: 8x11,19 m
 Base footprint: 7,8x9,34(+1,55) m
 Internal house area: 95,6 m²
 Terrace : 17,2 m²
 External wall area: 151 m²
 Roof area: 105,6 m²

Windows and doors:

Door: 1 single 100% glass 1,98x0,85 m and 6 single full wood 1,98x0,85 m
Window: 1 single 0,52x0,5 m, 1 single 0,92x0,7 m, 3 single 0,39x1,5 m, 1 single 1,98x0,5 m, 4 double 0,92x1,3 m and 3 double 1,98x1,5 m

Threshold: covered with steel

Installation kit:
Stair (straight):

*See optional products page 112

Sweden 7,5x13,5

Article No. S29346

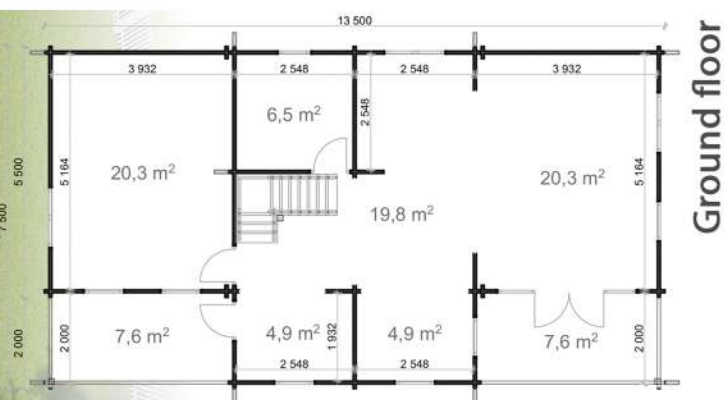
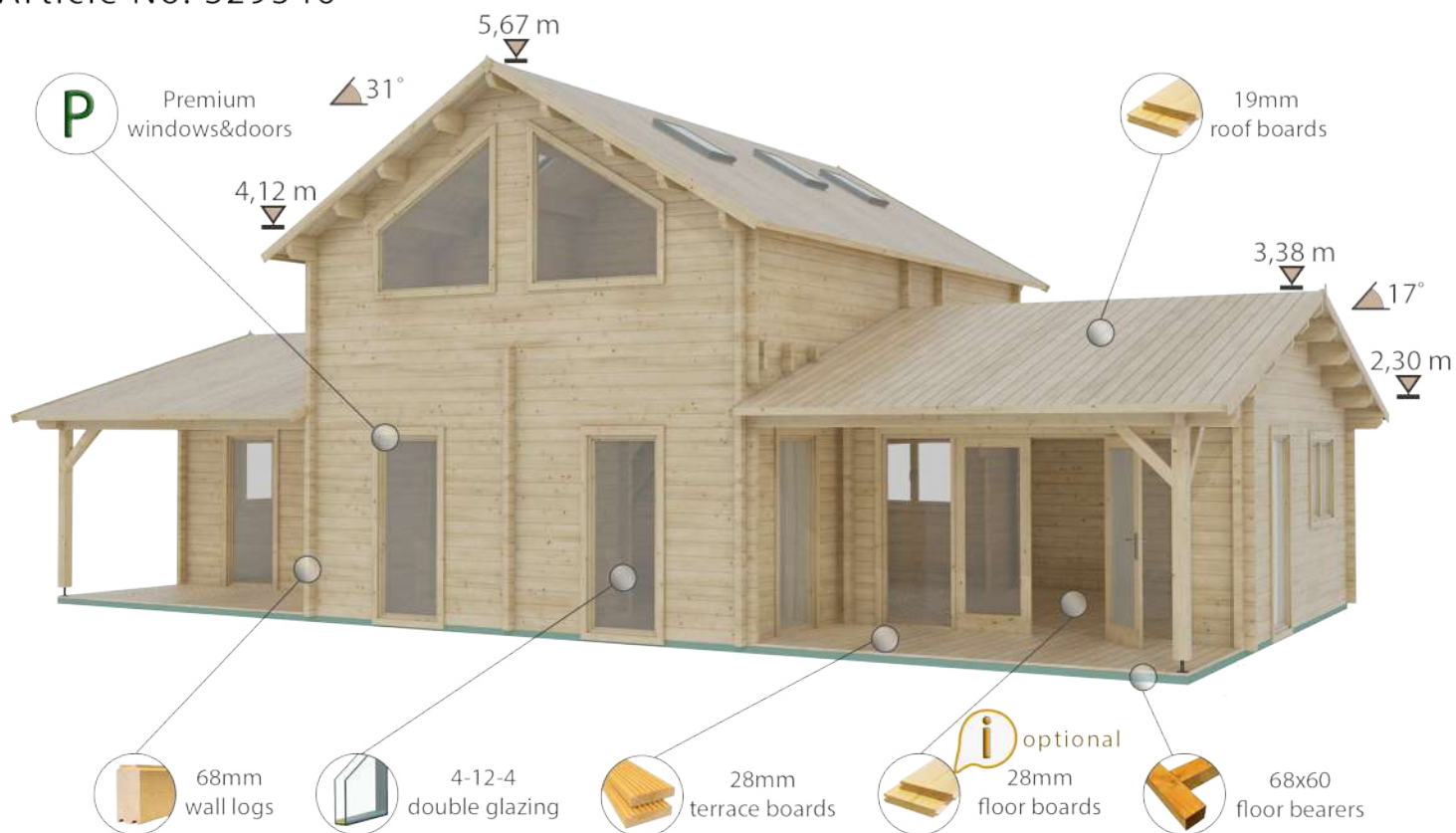

Ground floor

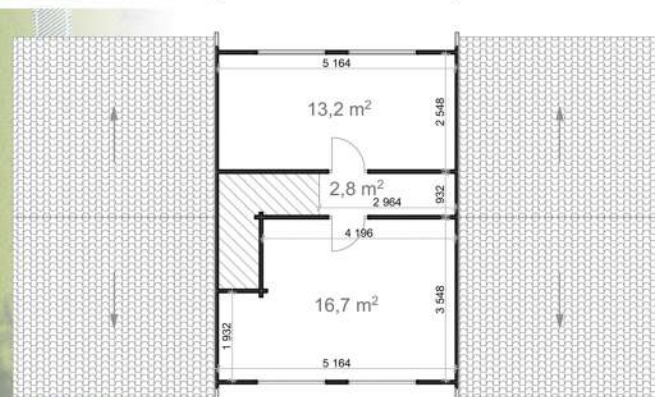

1st floor

Project specification:

External measures: 7,5x13,5 m
 Base footprint: 7,3x13,3 m
 Internal house area: 109,4 m²
 Terrace : 15,2 m²
 External wall area: 139,2 m²
 Roof area: 128,3 m²

Windows and doors:

Door: 1 single 100% glass 1,98x0,85 m,
 4 single full wood 1,98x0,85 m and
 1 quadruple 100% glass 1,98x3 m
 Window: 1 single 0,92x0,7 m, 6 single
 1,98x0,85 m, 3 double 0,92x1,3 m, 4
 trapezoid 1,6x1,5 m and 5 skylight

Threshold: covered with steel

Installation kit:
 Stair (L-shape):

*See optional products page 112

Talinn 5x10

Article No. S29347

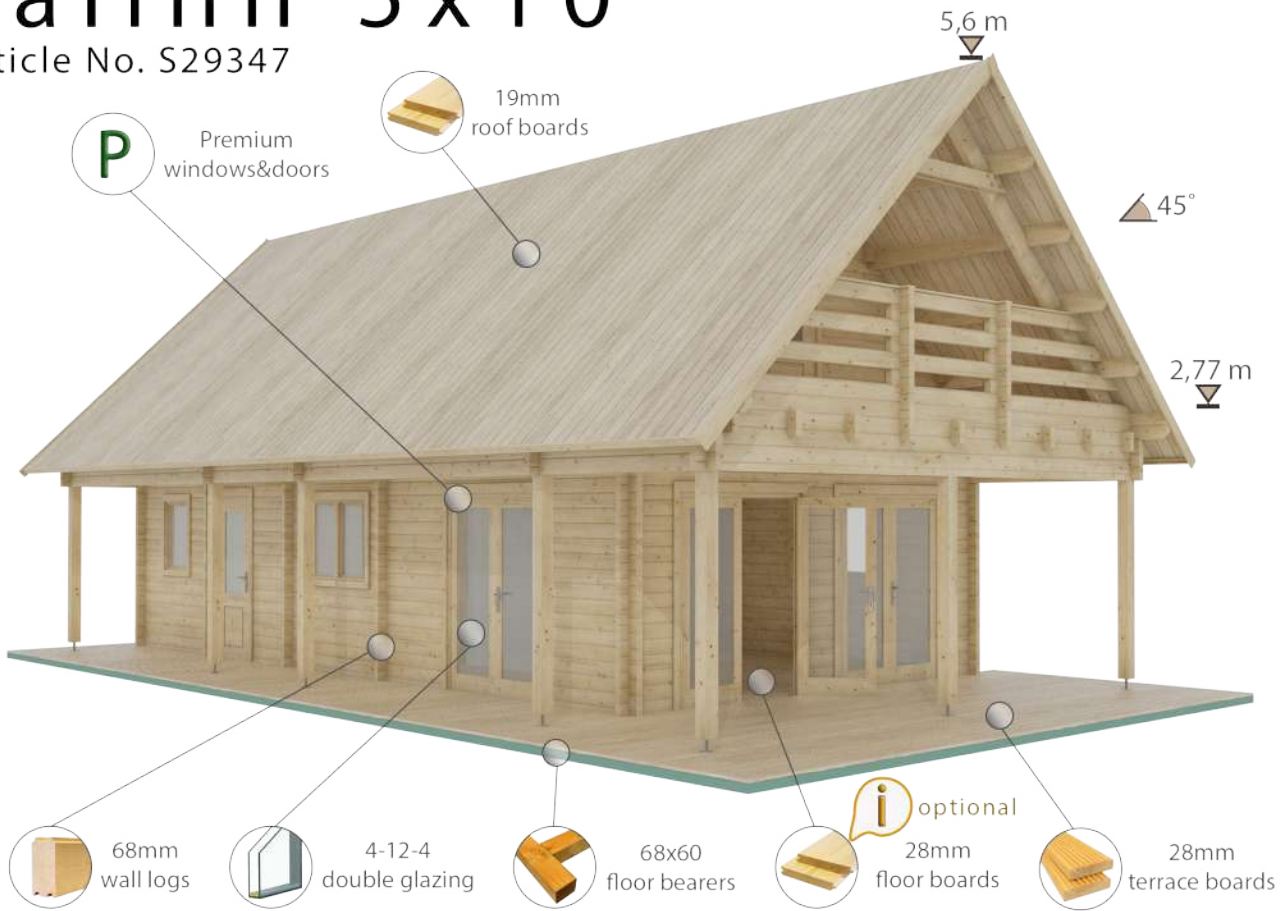

Ground floor

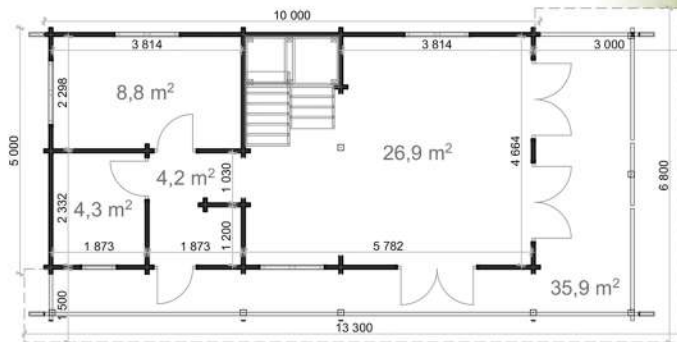

1st floor

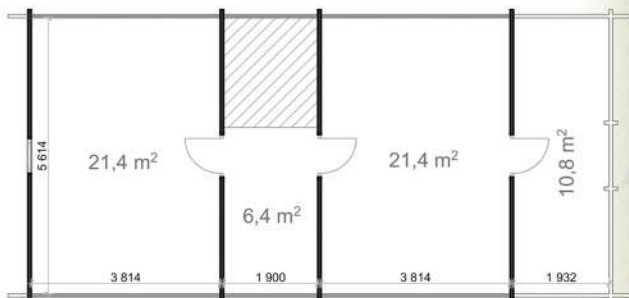

Project specification:

External measures: 5x10 m
 Base footprint: 4,8(+1,5)x9,8(+2,9) m
 Internal house area: 93,4 m²
 Terrace : 35,9 m² + 10,8 m² (balcony)
 External wall area: 151 m²
 Roof area: 105,6 m²

Windows and doors:

Door: 2 single 50% glass 1,98x0,85 m,
 4 single full wood 1,98x0,85 m and
 3 double 100% glass 1,98x1,6 m
 Window: 2 single 0,92x0,7 m and 4
 double 0,92x1,3 m
 Threshold: covered with steel

Installation kit:

Stair (straight):

*See optional products page 112

Verona 5,93x8,75

Article No. S26265

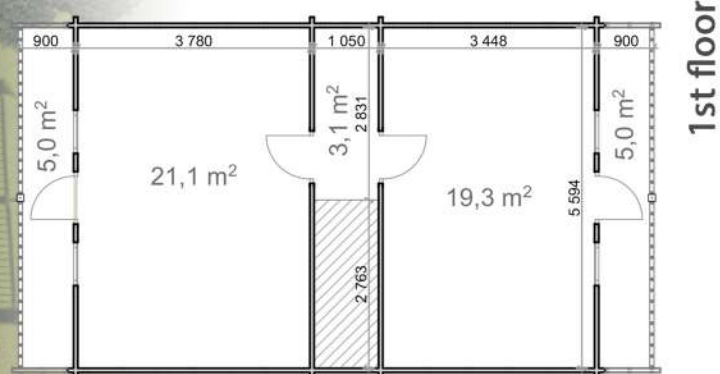
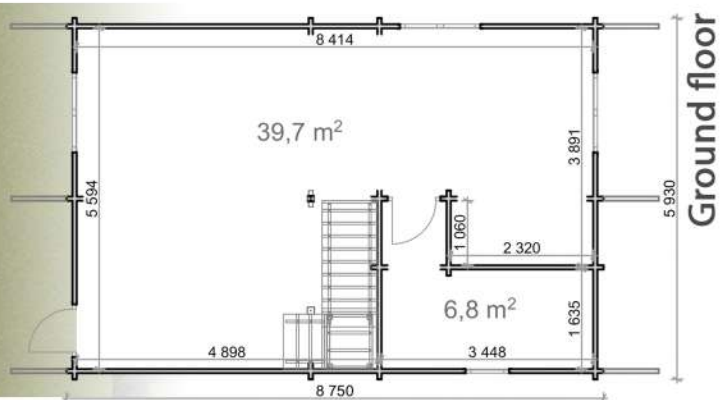
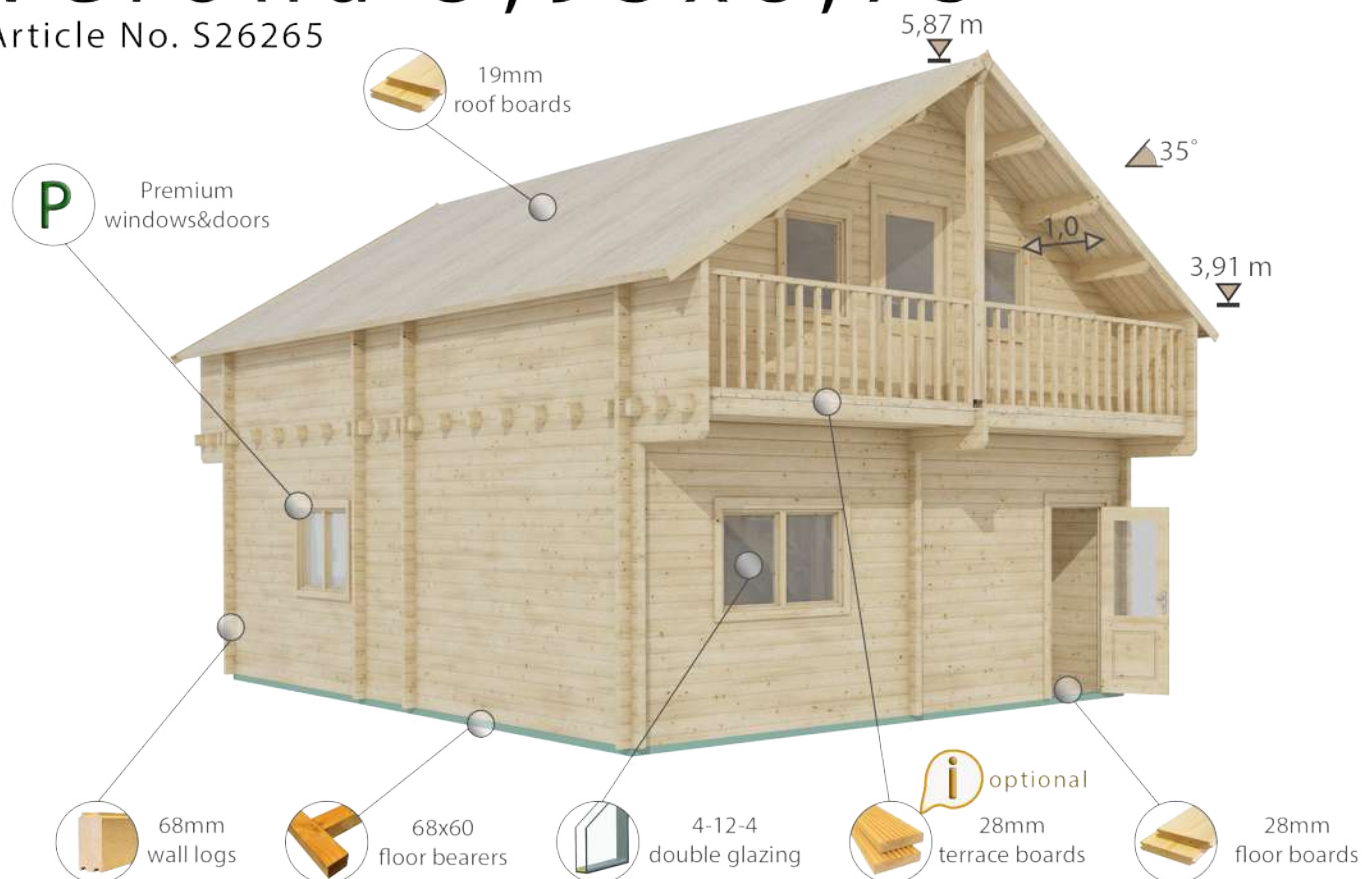

Project specification:

External measures: 5,93x8,75 m
 Base footprint: 5,73x8,55 m
 Internal house area: 90 m²
 Terrace : 10 m² (balcony)
 External wall area: 114 m²
 Roof area: 80,2 m²

Windows and doors:

Door: 3 single 50% glass 1,98x0,85 and 3 single full wood 1,98x0,85 m
 Window: 5 single 0,92x0,7 m and 3 double 0,92x1,3 m
 Threshold: covered with steel

Installation kit:

Stair (L-shape):

*See optional products page 112

Optional products

For country house/villa

Wall	Name	Article No.	Dipping (pine colour)	Bitumen roof tiles	Underlayer	EPDM roof cover	Metal roof cover	Rain gutters	Quality of windows and doors	Insulation
1 story	4.4 Arica 7x10	S26883	●			● 74m ²		●	HQ*, PVC*	Walls/roof/floor
	6.8 Granada 8,8x14	S26890	●			● 130m ²		●	HQ*, PVC*	Walls/roof/floor
	6.8 Leon 9,4x10,7	S26887	●			● 115m ²		●	HQ*, PVC*	Walls/roof/floor
	6.8 Orhidea 6x11,5	S26871	●	● 87m ²	● 85m'		●	●	P+, HQ*, PVC*	Walls/roof/floor
	6.8 Oskar 8,87x10,04	S27475	●	● 118m ²	● 107m'		●	●	P+, HQ*, PVC*	Walls/roof/floor
	6.8 Sevilla 7,8x13,74	S26260	●	● 152m ²	● 134m'		●	●	P+, HQ*, PVC*	Walls/roof/floor
	6.8 Takoma 12x8	S26884	●	● 126m ²	● 128m'		●	●	HQ*, PVC*	Walls/roof/floor
	6.8 Vienna 8,3x11	S26267	●	● 117m ²	● 115m'		●	●	P+, HQ*, PVC*	Walls/roof/floor
	6.8 Wendy 9,7x9,8	S26268	●	● 129m ²	● 125m'		●	●	P+, HQ*, PVC*	Walls/roof/floor
	6.8 Winnipeg 10,01x16,69	S26882	●			● 214m'		●	HQ*, PVC*	Walls/roof/floor
2 story	6.8 Athena 5,86x11,16	S27475	●	● 81m ²	● 83m'		●	●	P+, HQ*, PVC*	Walls/roof/floor
	6.8 Felix 6x10	S26218	●	● 102m ²	● 102m'		●	●	P+, HQ*, PVC*	Walls/roof/floor
	6.8 Nagano 10,14x8,04	S29344	●	● 117m ²	● 114m'		●	●	P+, HQ*, PVC*	Walls/roof/floor
	6.8 Porto 9,2x13,2	S26281	●	● 129m ²	● 130m'		●	●	P+, HQ*, PVC*	Walls/roof/floor
	6.8 Salvador 8x11,19	S26282	●	● 117m ²	● 117m'		●	●	P+, HQ*, PVC*	Walls/roof/floor
	6.8 Sweden 7,5x13,5	S29346	●	● 144m ²	● 143m'		●	●	P+, HQ*, PVC*	Walls/roof/floor
	6.8 Talinn 5x10	S29347	●	● 120m ²	● 117m'		●	●	P+, HQ*, PVC*	Walls/roof/floor
	6.8 Verona 5,93x8,75	S26265	●	● 87m ²	● 89m'		●	●	P+, HQ*, PVC*	Walls/roof/floor



*Note: HQ or PVC windows&doors quality option for 44mm wall thickness is available if wall insulation is included.



Garages & carports



Garage



Carport

Garage p.116-119



Garage 3,2x5,2 (28mm)
p.116



Garage 3,2x5,2 (44mm)
p.116



Garage 4x6
p.117



Garage 5x5
p.117



Garage 6x6
p.118



Garage+carport 6,8x5,6
p.118



Garage 7x5,5
p.119



Garage 6x9
p.119

Carport p.120-122



Carport+storage 5,7x5,3
p.120



Carport+storage 5,7x7,9
p.120



Carport-Fugi
p.121



Carport-Mars
p.121



Carport-Niki
p.122



Carport-Pablo
p.122

Garage 3,2x5,2

Article No. S26749



Project specification:

External measures: 3,2x5,2 m
 Base footprint: 3x5 m
 Internal house area: 14,6m²
 External wall area: 31 m²
 Roof area: 19,9 m²

Windows and doors:

Door: 1 single 50% glass 1,85x0,85 m
 Window: 1 double 0,92x1x3 m
 Garage gate (optional): 1 wooden, metal (manual) or metal (automatic)
 Threshold: covered with steel

Possible reverse montage:

Installation kit:

Storm braces:

*See optional products page 123

Garage 3,2x5,2

Premium - Article No. S26221

Economy - Article No. S27265



Project specification:

External measures: 3,2x5,2 m
 Base footprint: 3x5 m
 Internal house area: 14,3 m²
 External wall area: 33 m²
 Roof area: 20,3 m²

Windows and doors:

Door:
 Premium - 1 single 50% glass 1,98x0,85 m
 Economy - 1 single 50% glass 1,85x0,85 m
 Window: 1 double 0,92x1x3 m
 Garage gate (optional): 1 wooden, metal (manual) or metal (automatic)

Threshold: covered with steel

Possible reverse montage:

Installation kit:

Storm braces:

*See optional products page 123

Garage 4x6

Premium - Article No. S26223

Economy - Article No. S27266

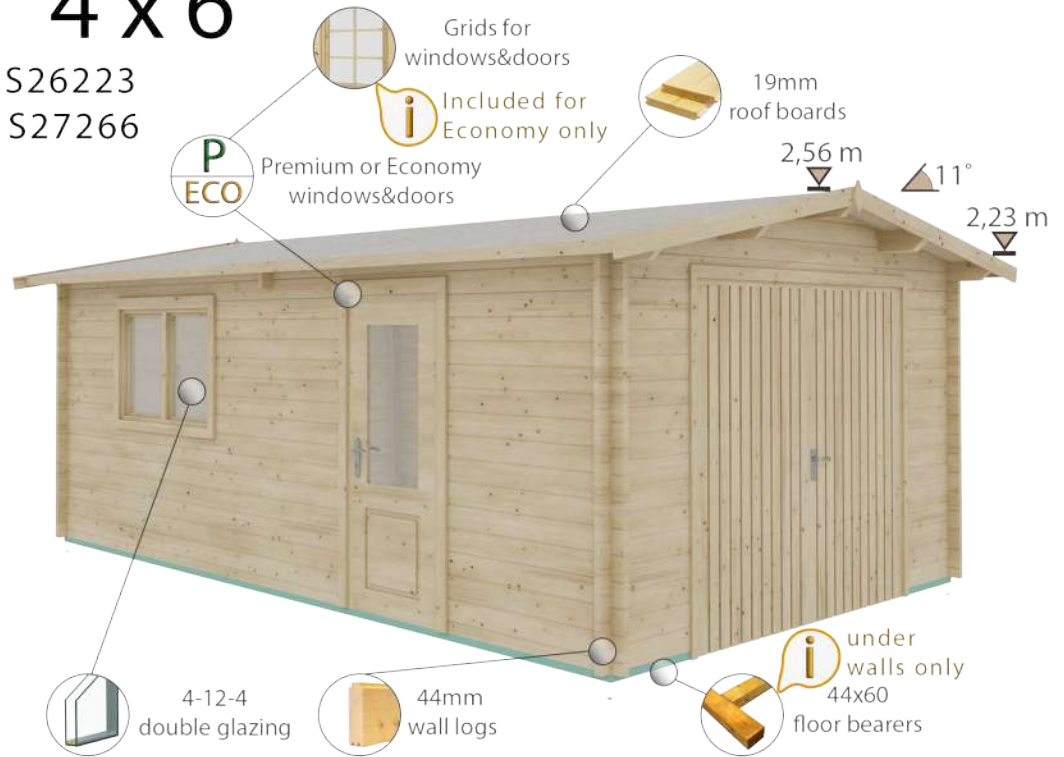
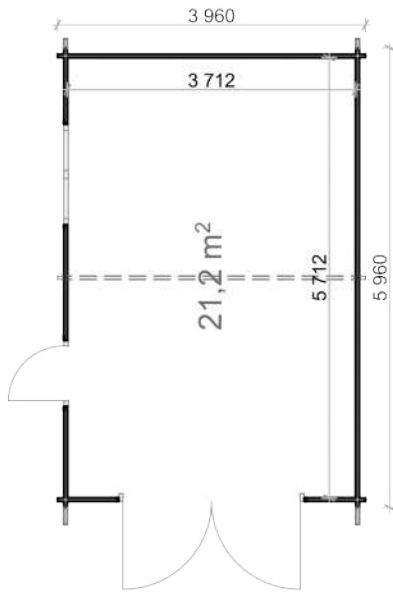

Project specification:

External measures: 4x6 m
 Base footprint: 3,8x5,8 m
 Internal house area: 21,2 m²
 External wall area: 40 m²
 Roof area: 27,5 m²

Windows and doors:

Door:
Premium - 1 single 50% glass 1,98x0,85 m
Economy - 1 single 50% glass 1,85x0,85 m
Window: 1 double 0,92x1,3 m
Garage gate (optional): 1 wooden, metal (manual) or metal (automatic)

Threshold: covered with steel

Possible reverse montage:

Installation kit:

Storm braces:

*See optional products page 123

Garage 5x5

Premium - Article No. S26273

Economy - Article No. S27268

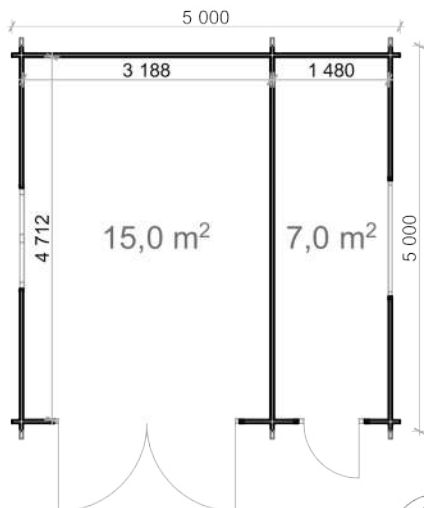

Project specification:

External measures: 5x5 m
 Base footprint: 4,8x4,8 m
 Internal house area: 22 m²
 External wall area: 40 m²
 Roof area: 28 m²

Windows and doors:

Door:
Premium - 1 single full wood 1,98x0,85 m
Economy - 1 single full wood 1,85x0,85 m
Window: 1 double 0,92x1x3 m and 1 single 0,39x1,5 m
Garage gate (optional): 1 wooden, metal (manual) or metal (automatic)

Threshold: covered with steel

Possible reverse montage:

Installation kit:

Storm braces:

*See optional products page 123

Garage 6x6

Premium - Article No. S26222

Economy - Article No. S27270

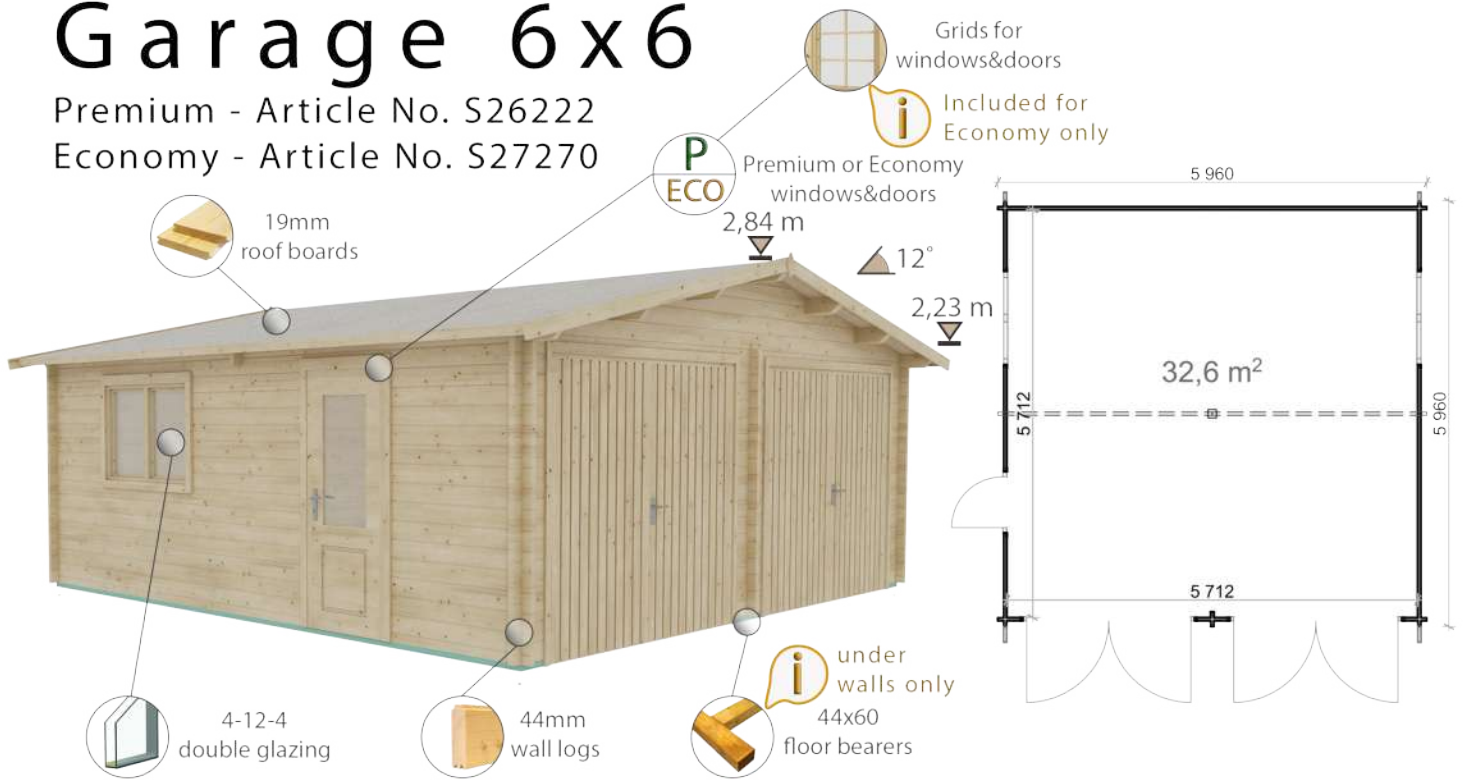

Project specification:

External measures: 5,96x5,96 m

Base footprint: 5,8x5,8 m

Internal house area: 32,6 m²

External wall area: 46 m²

Roof area: 40,6 m²

Windows and doors:

Door:

Premium - 1 single 50% glass 1,98x0,85 m

Economy - 1 single 50% glass 1,85x0,85 m

Window: 2 double 0,92x1x3 m

Garage gate (optional): 2 wooden, metal (manual) or metal (automatic)

Threshold: covered with steel

Possible reverse montage:

Installation kit:

Storm braces:

*See optional products page 123

Garage+carport 6,8x5,6

Premium - Article No. S26219

Economy - Article No. S27262

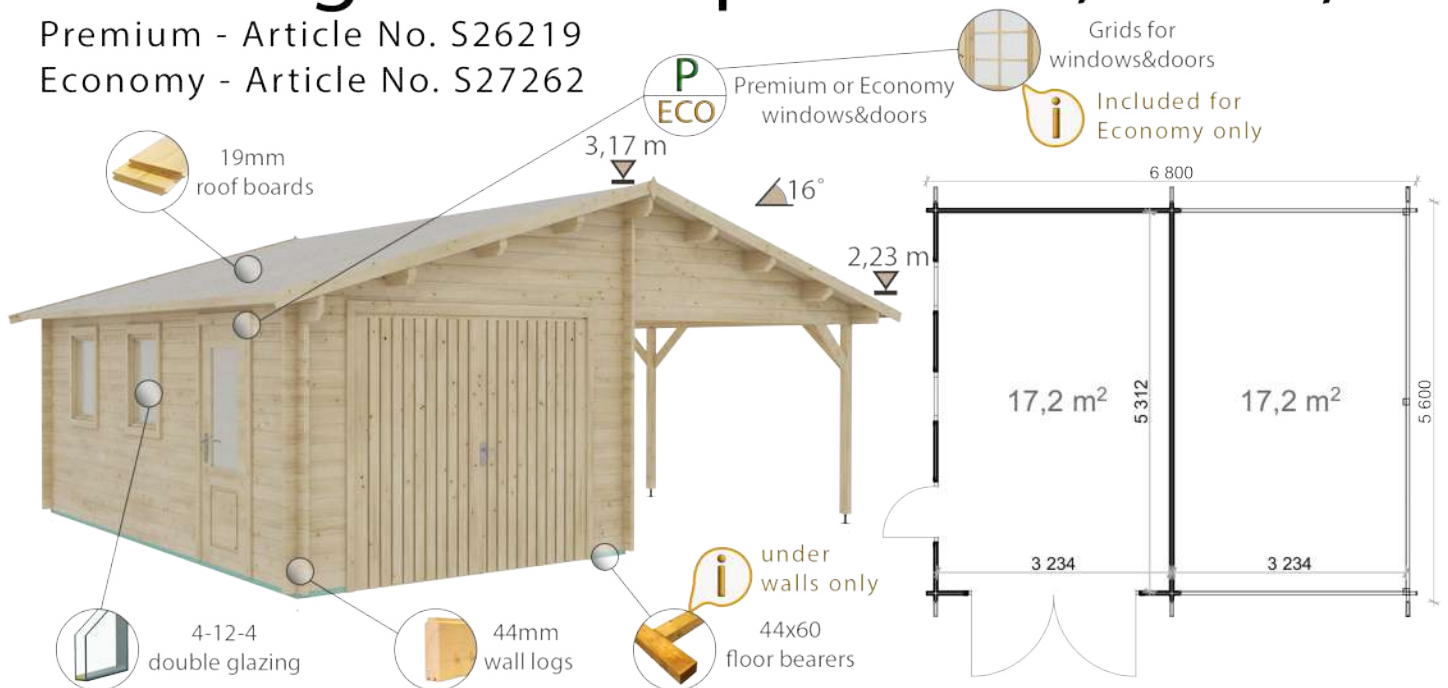

Project specification:

External measures: 6,8x5,6 m

Base footprint: 3,322(+3,27)x5,4 m

Internal house area: 17,2 m²

+ 17,2 m² (canopy)

External wall area: 42 m²

Roof area: 44,4 m²

Windows and doors:

Door:

Premium - 1 single 50% glass 1,98x0,85 m

Economy - 1 single 50% glass 1,85x0,85 m

Window: 2 single 0,92x0,7 m

Garage gate (optional): 1 wooden, metal (manual) or metal (automatic)

Threshold: covered with steel

Possible reverse montage:

Installation kit:

Storm braces:

*See optional products page 123

Garage 7x5,5

Premium - Article No. S26930

Economy - Article No. S26274

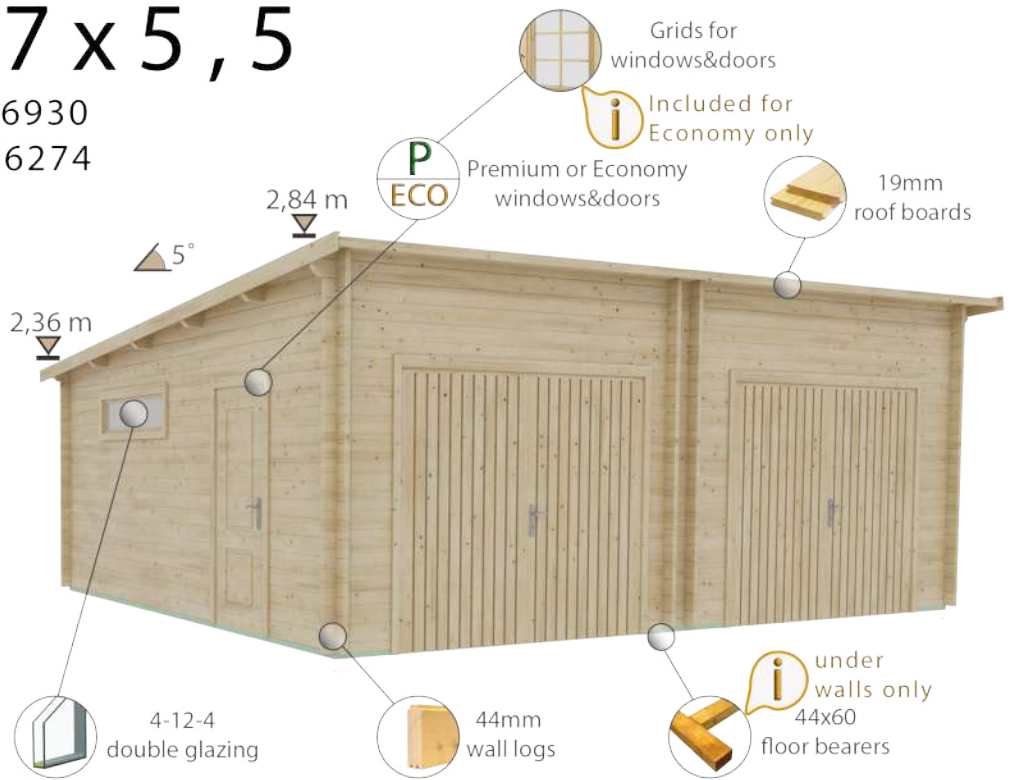
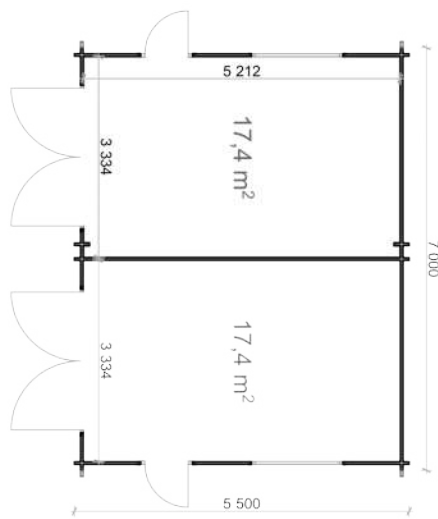

Project specification:

External measures: 7x5,5 m
 Base footprint: 6,8x5,3 m
 Internal house area: 34,8 m²
 External wall area: 53 m²
 Roof area: 41,9 m²

Windows and doors:

Door:
Premium - 2 single full wood glass 1,98x0,85 m
Economy - 2 single full wood glass 1,85x0,85 m
Window: 2 single 0,39x1,5 m
Garage gate (optional): 2 wooden, metal (manual) or metal (automatic)

Threshold: covered with steel

Possible reverse montage:
Installation kit:
Storm braces:

*See optional products page 123

Garage 6x9

Premium - Article No. S26741

Economy - Article No. S26355

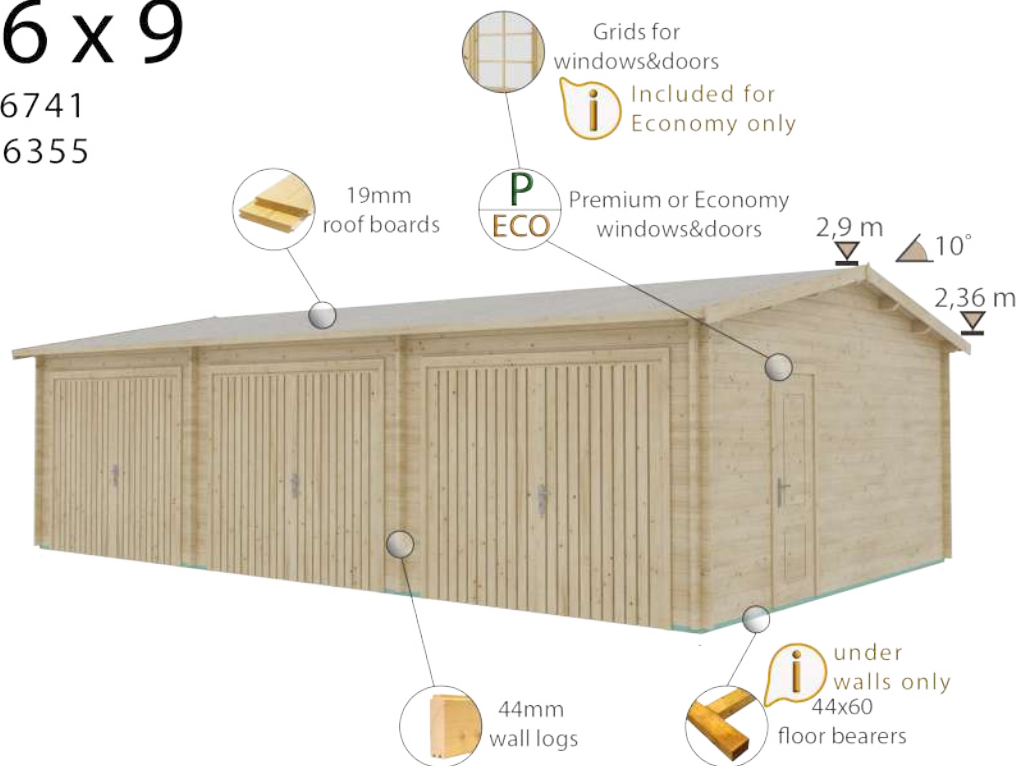
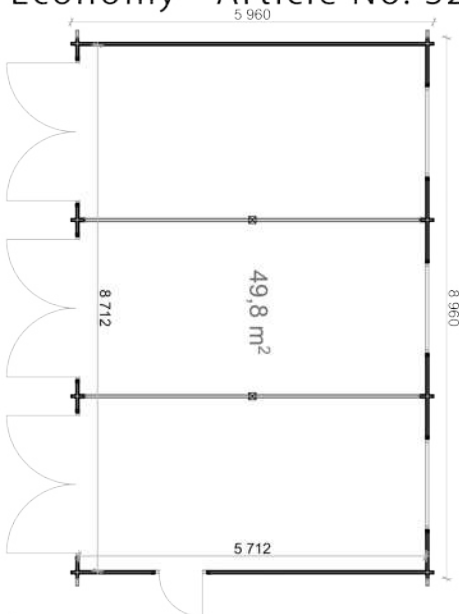

Project specification:

External measures: 5,96x8,96 m
 Base footprint: 5,8x8,8 m
 Internal house area: 49,8 m²
 External wall area: 60 m²
 Roof area: 59 m²

Windows and doors:

Door:
Premium - 1 single full wood 1,98x0,85 m
Economy - 1 single full wood 1,85x0,85 m
Window: 1 double 0,92x1x3 m and 3 single 0,39x1,5 m
Garage gate (optional): 3 wooden, metal (manual) or metal (automatic)

Threshold: covered with steel

Possible reverse montage:
Installation kit:
Storm braces:

*See optional products page 123

44 Carport+storage 5,7x5,3

Article No. S29353

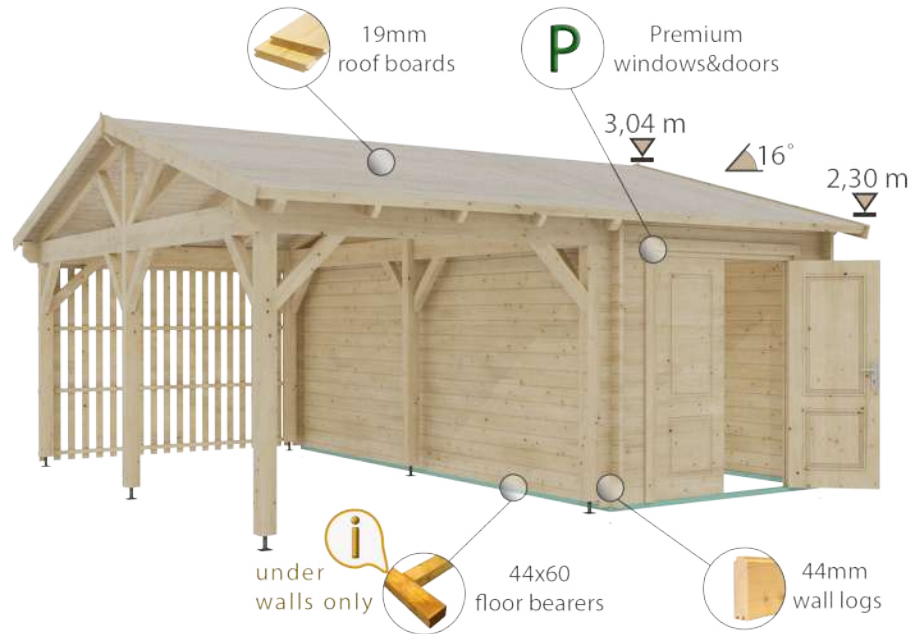
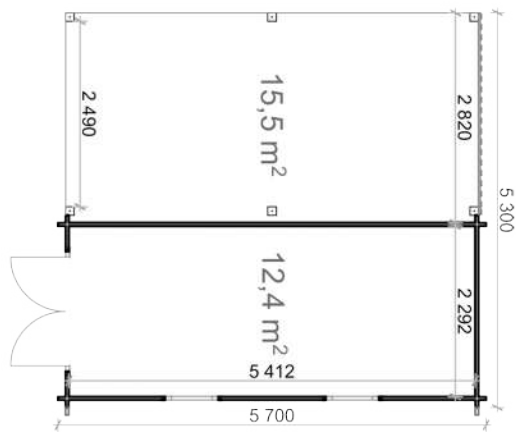

Project specification:

External measures: 5,7x5,3 m
 Base footprint: 5,5x5,2 m
 Internal house area: 12,4 m²
 Canopy area: 15,5 m²
 External wall area: 39 m²
 Roof area: 34,6 m²

Windows and doors:

Door: 1 double full wood 1,98x1,6 m
 Window: 2 single 0,39x0,7 m
 Threshold: covered with steel

Possible reverse montage:

Installation kit:

Storm braces:

*See optional products page 123

44 Carport+storage 5,7x7,9

Article No. S29354

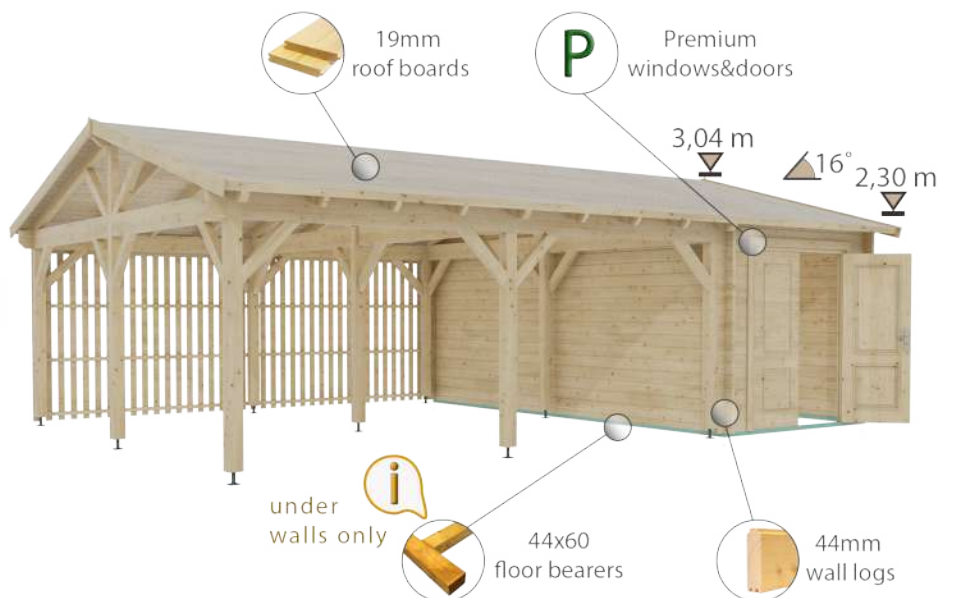
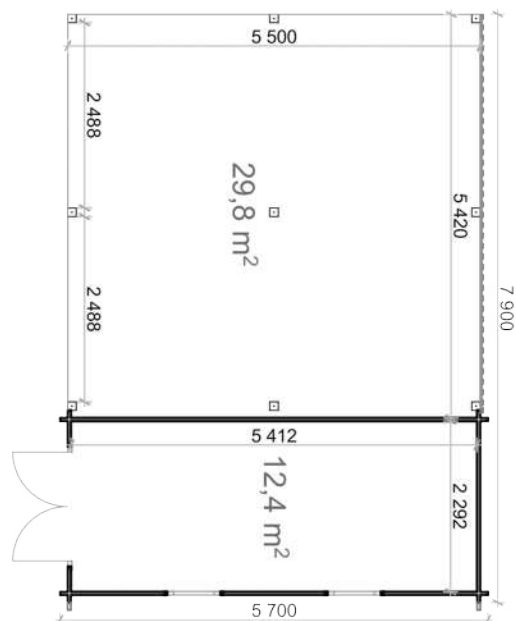

Project specification:

External measures: 5,7x7,9 m
 Base footprint: 5,5x7,8 m
 Internal house area: 12,4 m²
 Canopy area: 29,8 m²
 External wall area: 39 m²
 Roof area: 50,7 m²

Windows and doors:

Door: 1 double full wood 1,98x1,6 m
 Window: 2 single 0,39x0,7 m
 Threshold: covered with steel

Possible reverse montage:

Installation kit:

Storm braces:

*See optional products page 123

Carport-Fugi

Article No. S29352

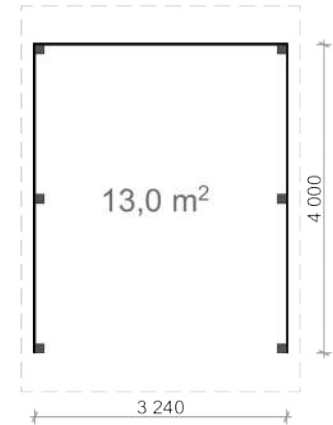
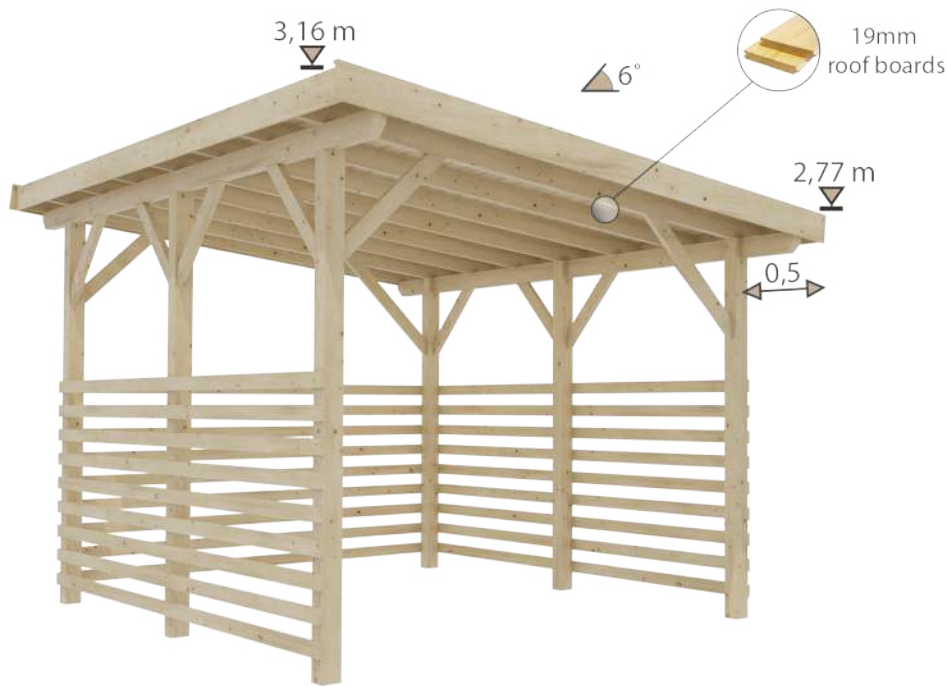

Project specification:

External measures: 3,24x4 m

Canopy area: 13 m²

Roof area: 18 m²

Possible reverse montage:

Installation kit:

*See optional products page 123

Carport-Mars

Article No. S27781

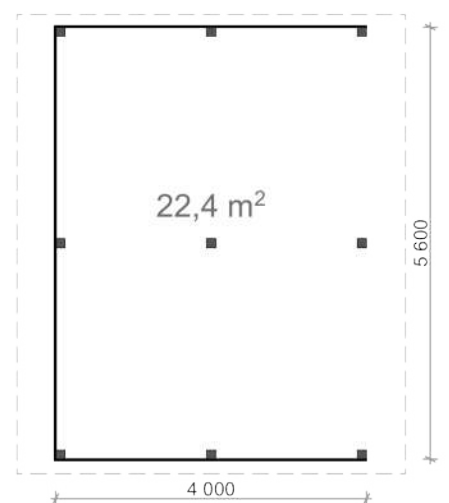
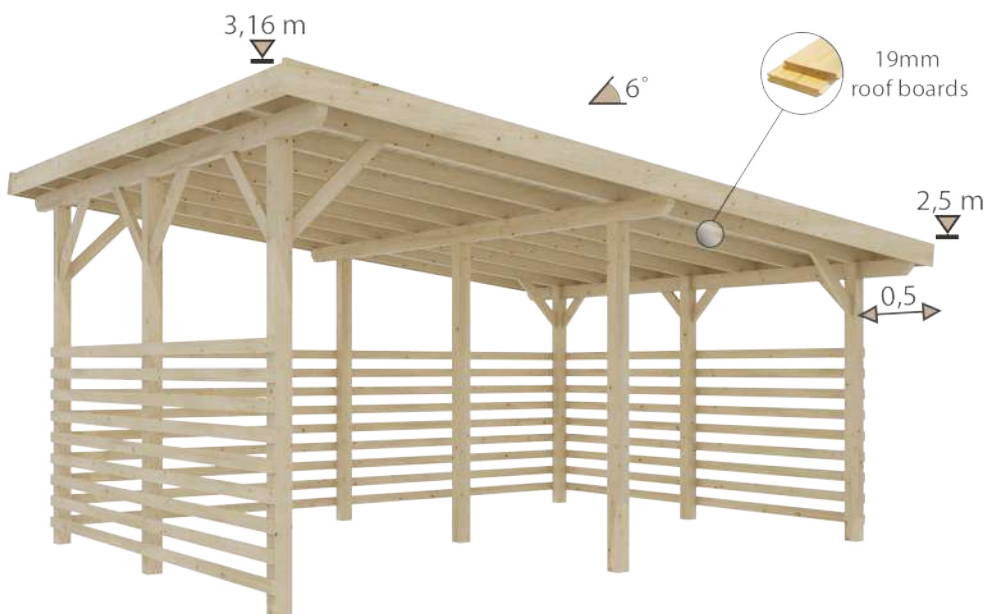

Project specification:

External measures: 5,6x4 m

Canopy area: 22,4 m²

Roof area: 30 m²

Possible reverse montage:

Installation kit:

*See optional products page 123

Carport-Niki

Article No. S29355

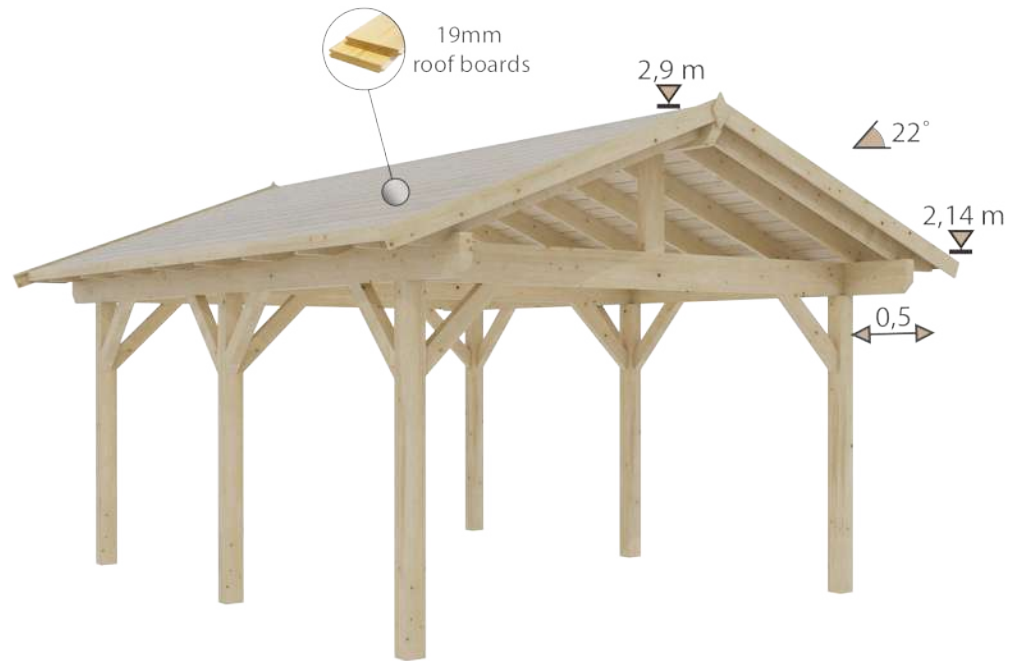
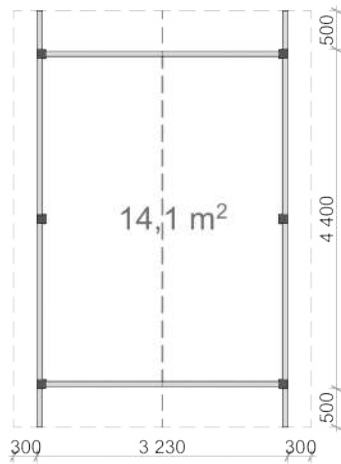

Project specification:

External measures: 3,23x4,4 m

Canopy area: 14,1 m²

Roof area: 22,3 m²

Possible reverse montage:

Installation kit:

*See optional products page 123

Carport-Pablo

Article No. S29356

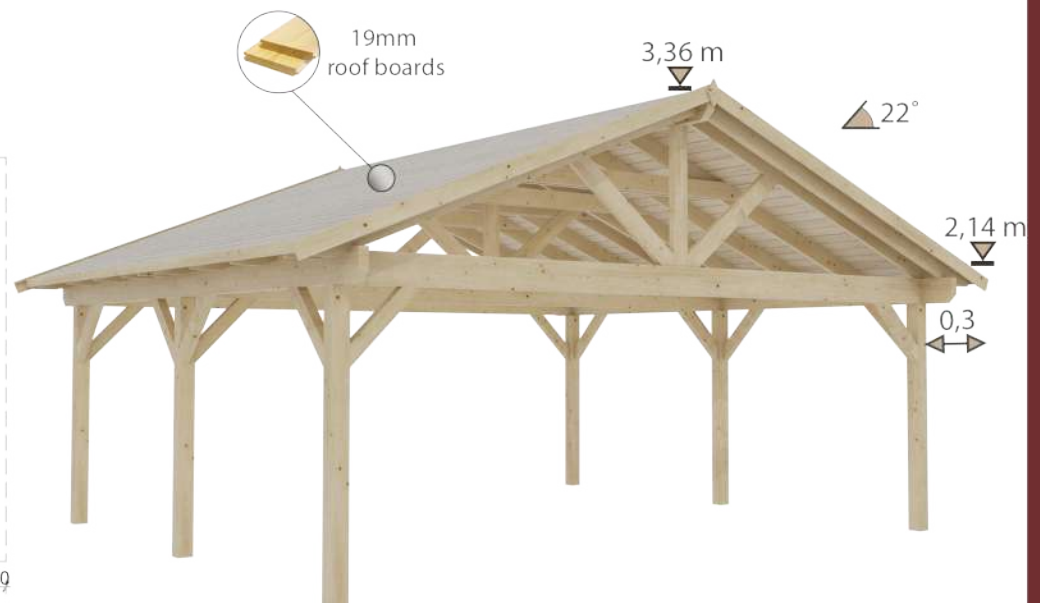
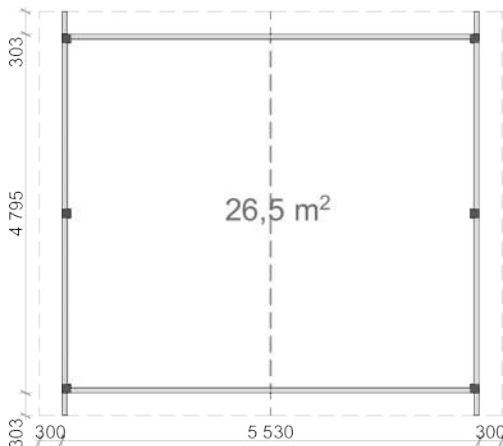

Project specification:

External measures: 5,53x4,795 m

Canopy area: 26,5 m²

Roof area: 35,7 m²

Possible reverse montage:

Installation kit:

*See optional products page 123

Optional products

For garages&carports

Wall	Name	Article No. Premium/Economy	Dipping (pine colour)	Bitumen roof tiles	Underlayer	Metal roof cover	Rain gutters
2 8	Garage 3,2x5,2	S26749	●	● 24m ²	● 22m'		●
4 4	Garage 3,2x5,2	S26221/S27265	●	● 24m ²	● 23m'	●	●
4 4	Garage 4x6	S26223/S27266	●	● 30m ²	● 31m'	●	●
4 4	Garage 5x5	S26273/S27268	●	● 30m ²	● 31m'	●	●
4 4	Garage 6x6	S26222/S27270	●	● 45m ²	● 45m'	●	●
4 4	Garage+carport 6,8x5,6	S26219/S27262	●	● 48m ²	● 49m'	●	●
4 4	Garage 7x5,5	S26930/S26274	●	● 45m ²	● 47m'	●	●
4 4	Garage 6x9	S26741/S26355	●	● 63m ²	● 66m'	●	●
4 4	Carport+storage 5,7x5,3	S29353	●	● 42m ²	● 42m'	●	●
4 4	Carport+storage 5,7x7,9	S29354	●	● 54m ²	● 54m'	●	●
N/A	Carport-Fuji	S29352	●	● 21m ²	● 21m'		●
N/A	Carport-Mars	S27781	●	● 33m ²	● 33m'		●
N/A	Carport-Niki	S29355	●	● 27m ²	● 26m'	●	●
N/A	Carport-Pablo	S29356	●	● 42m ²	● 43m'	●	●

Pergolas





Pergola-Haga p. 126



Pergola-Kipa p. 126



Pergola-Linsi p. 127



Pergola-Luna p. 127



Pergola-Missy p. 128



Pergola-Oli p. 128



Pergola-Rose p. 129



Pergola-Uma p. 129



Pergola-Zulu p. 130



Pergola-Haga

Article No. S26874

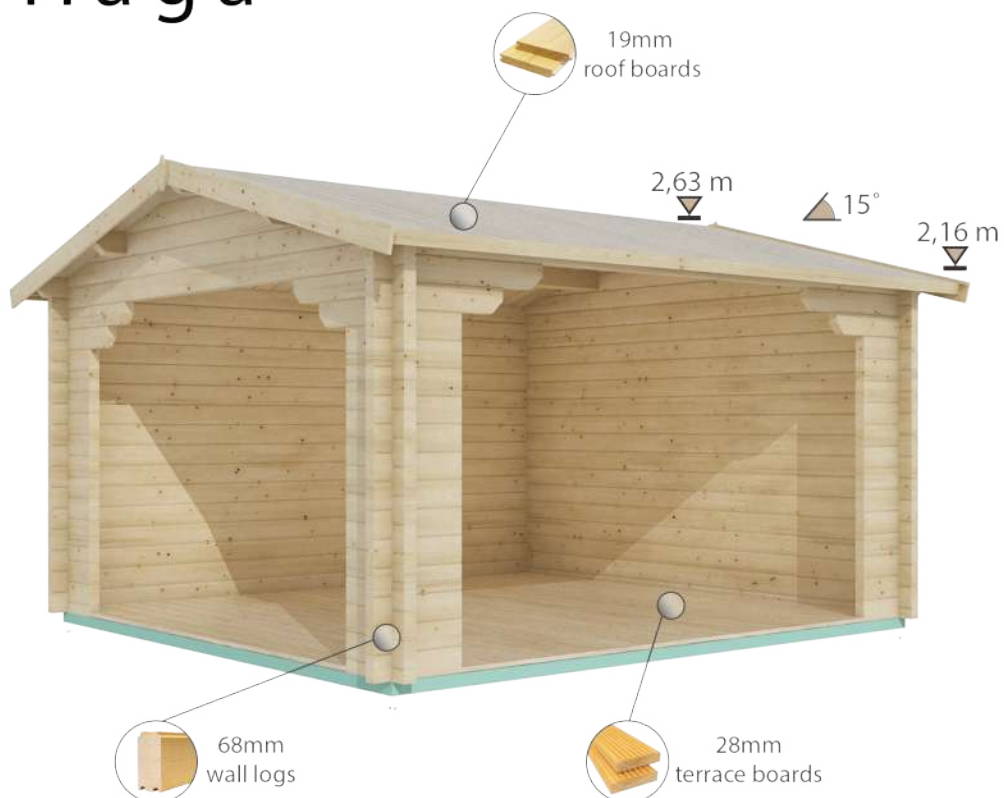
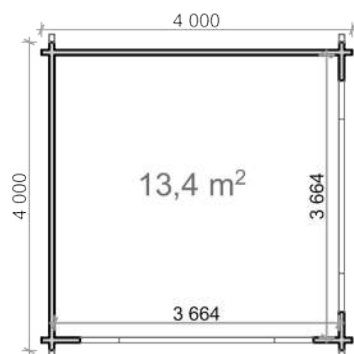

Project specification:

External measures: 4x4 m

Base footprint: 3,8x3,8 m

External wall area: 25,3 m²

Canopy area: 13,4 m²

Roof area: 18,7 m²

Possible reverse montage:

Installation kit:

*See optional products page 131

Pergola-Kipa

Article No. S26876

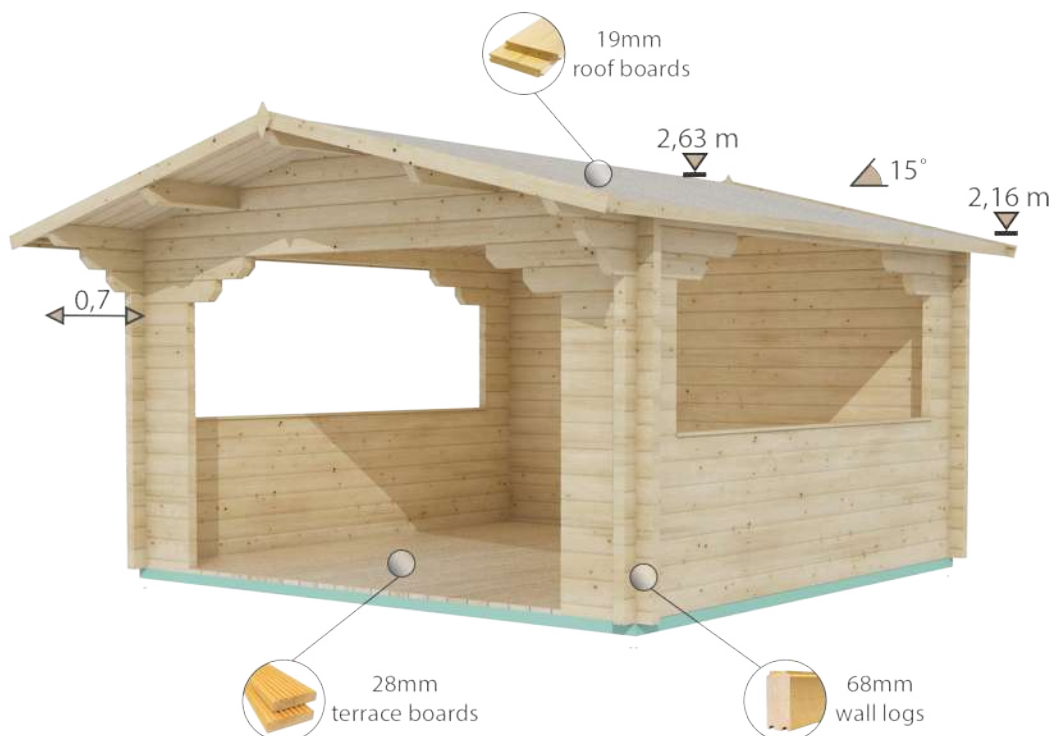
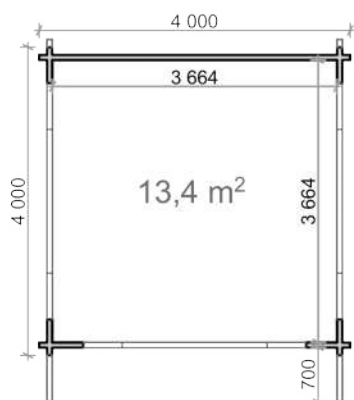

Project specification:

External measures: 4x4 m

Base footprint: 3,8x3,8 m

External wall area: 25,6 m²

Canopy area: 13,4 m²

Roof area: 20,9 m²

Possible reverse montage:

Installation kit:

*See optional products page 131

Pergola-Linsi

Article No. S26877

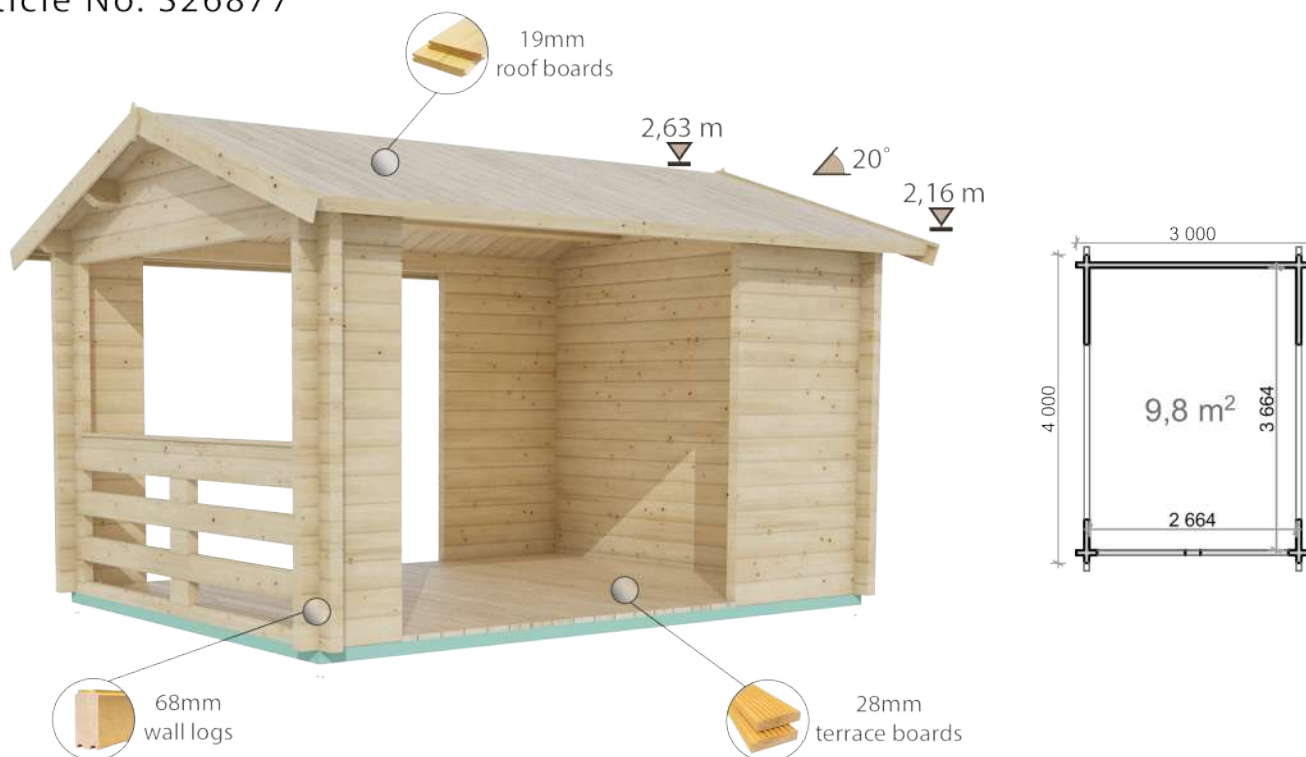

Project specification:

External measures: 3x4 m

Base footprint: 2,8x3,8 m

External wall area: 19,5 m²

Canopy area: 9,8 m²

Roof area: 14,7 m²

Possible reverse montage:

Installation kit:

*See optional products page 131

Pergola-Luna

Article No. S26878

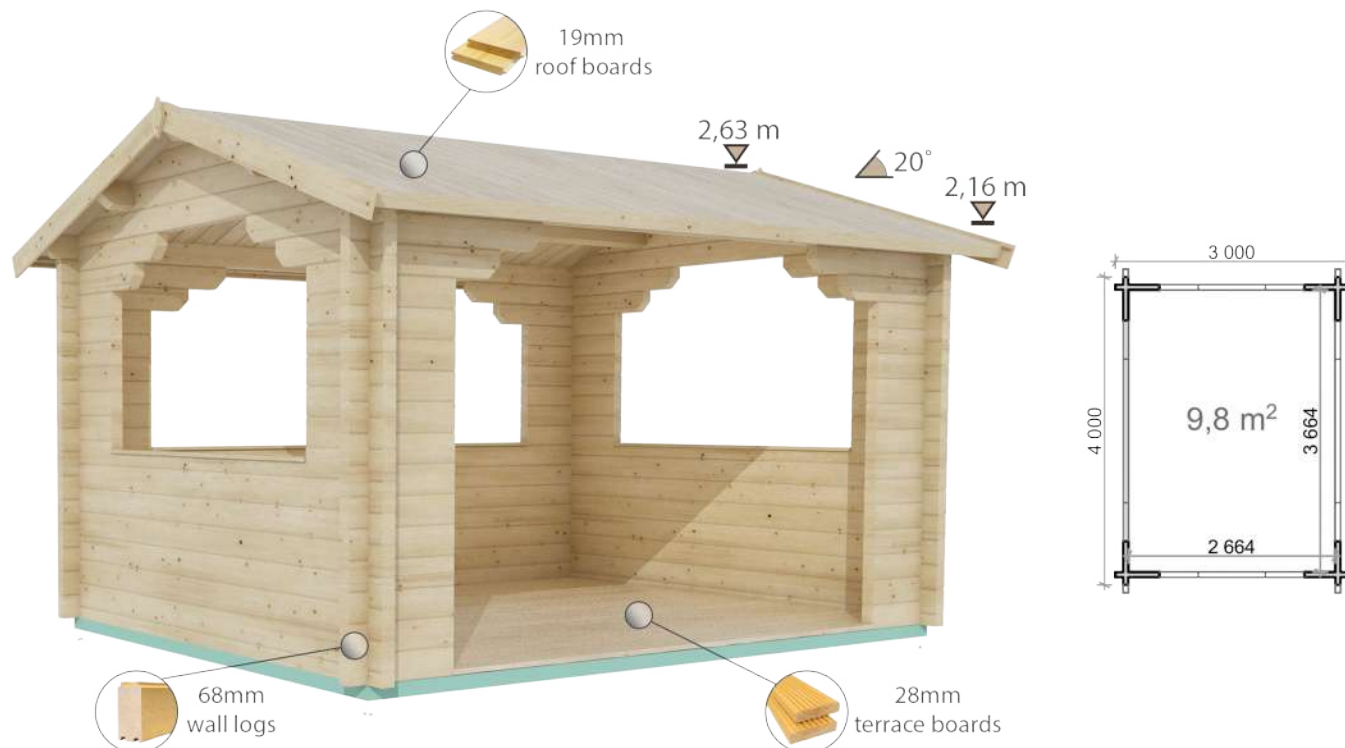

Project specification:

External measures: 3x4 m

Base footprint: 2,8x3,8 m

External wall area: 19,8 m²

Canopy area: 9,8 m²

Roof area: 14,7 m²

Possible reverse montage:

Installation kit:

*See optional products page 131

Pergola-Missy

Article No. S29357

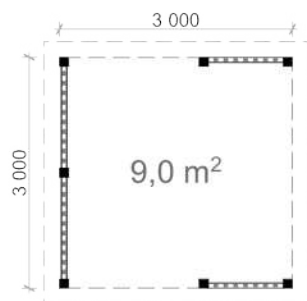

Project specification:

External measures: 3x3 m

Canopy area: 9 m²

Roof area: 11,6 m²

Possible reverse montage:

Installation kit:

*See optional products page 131

Pergola-Oli

Article No. S29358

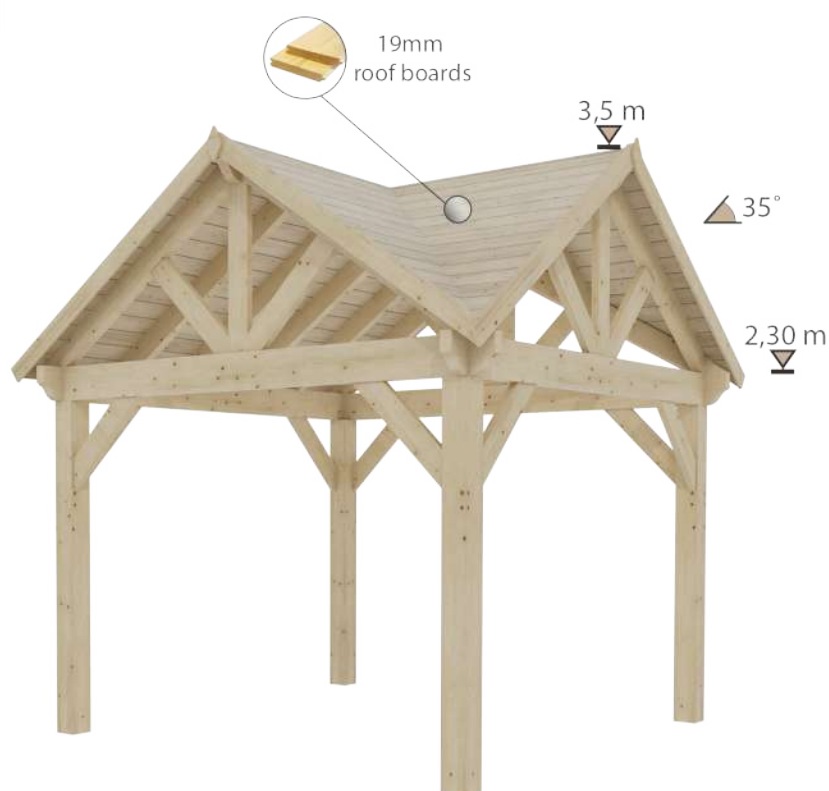
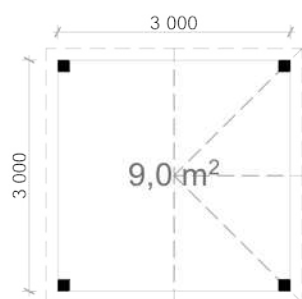

Project specification:

External measures: 3x3 m

Canopy area: 9 m²

Roof area: 14 m²

Possible reverse montage:

Installation kit:

*See optional products page 131

Pergola-Rose

Article No. S29359

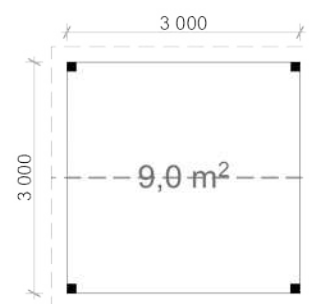
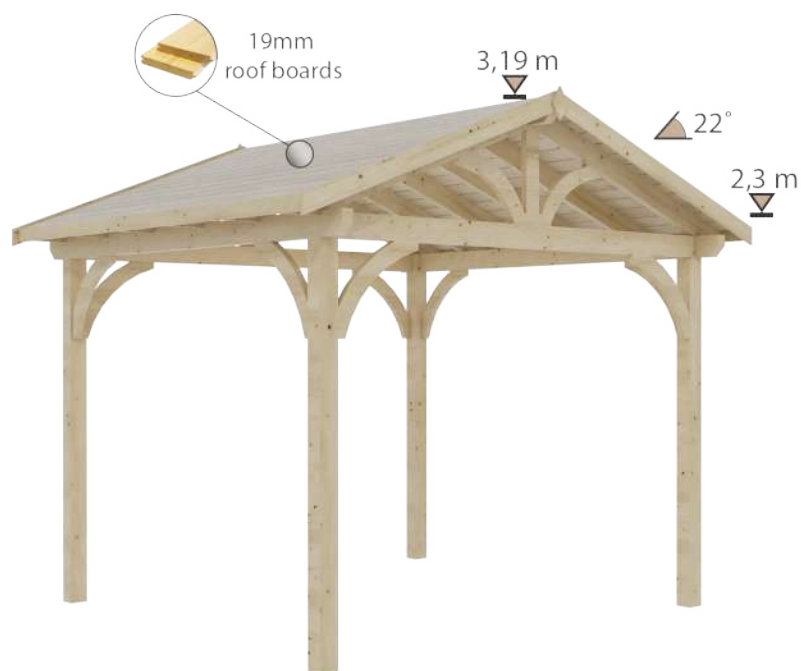

Project specification:

External measures: 3x3 m

Canopy area: 9 m²

Roof area: 12,5 m²

Possible reverse montage:

Installation kit:

*See optional products page 131

Pergola-Uma

Article No. S29360

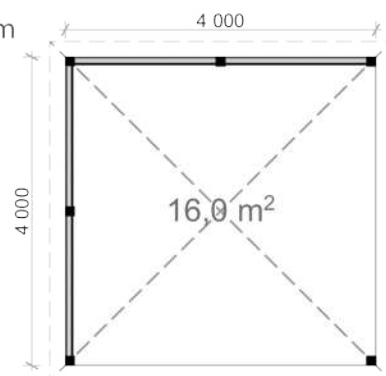
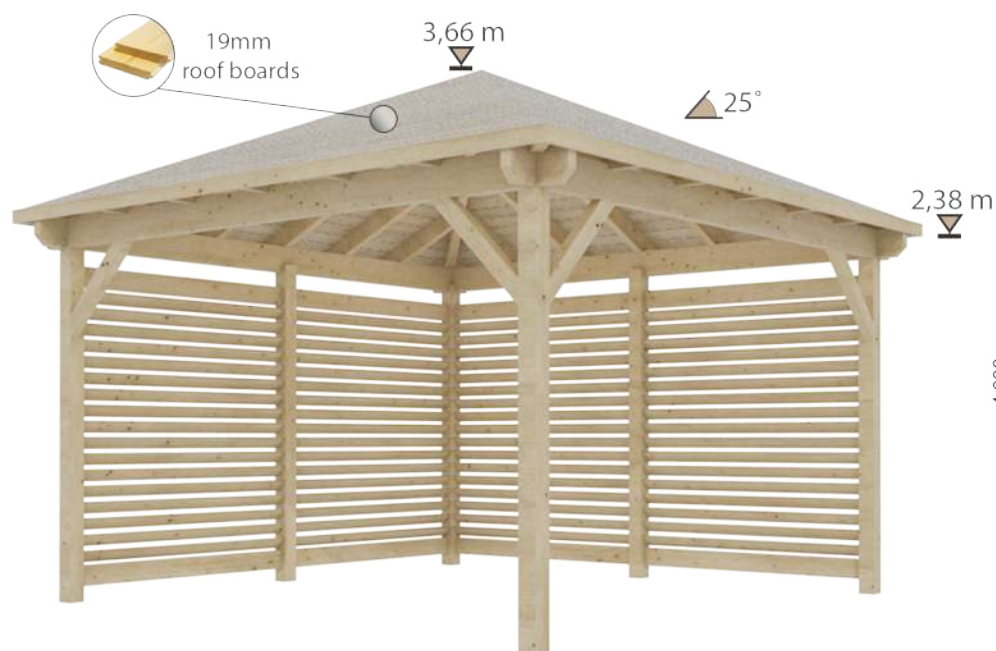

Project specification:

External measures: 4x4 m

Canopy area: 16 m²

Roof area: 21,5 m²

Possible reverse montage:

Installation kit:

*See optional products page 131

Pergola-Zulu

Article No. S29361

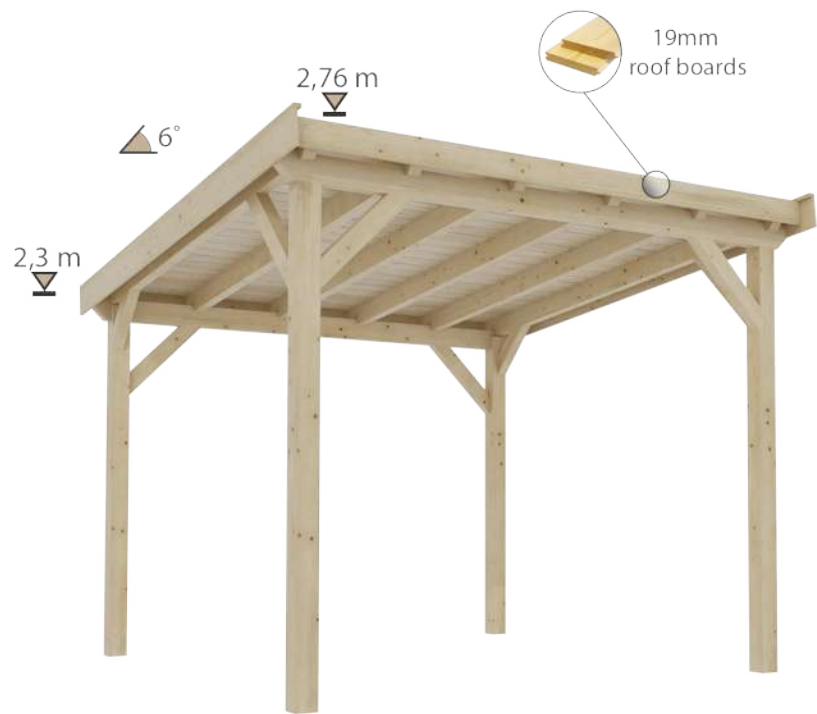
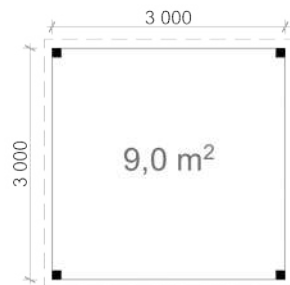

Project specification:

External measures: 3x3 m

Canopy area: 9 m²

Roof area: 10,3 m²

Possible reverse montage:

Installation kit:

*See optional products page 131



Optional products

For pergolas

Wall	Name	Article No.	Dipping (pine colour)	Bitumen roof tiles	Underlayer
6 8	Pergola-Haga	S26874	●	● 24m ²	● 21m'
6 8	Pergola-Kipa	S26876	●	● 24m ²	● 23m'
6 8	Pergola-Linsi	S26877	●	● 21m ²	● 16m'
6 8	Pergola-Luna	S26878	●	● 21m ²	● 16m'
N/A	Pergola-Missy	S29357	●	● 15m ²	● 12m'
N/A	Pergola-Oli	S29358	●	● 18m ²	● 16m'
N/A	Pergola-Rose	S29359	●	● 15m ²	● 14m'
N/A	Pergola-Uma	S29360	●	● 27m ²	● 24m'
N/A	Pergola-Zulu	S29361	●	● 12m ²	● 12m'

New concept

New concept

132-135



We are is always happy to see customers appreciating wooden structures and valuing it's benefits.

From small cabins for those who just want to bring order to their garden, to garden houses for you as relaxing, working, meditating and crafting space, or big summer houses, villas or the most unique bespoke projects, where you can spend weekends and holidays with family and friends.



A-frame-7,6

Article No. N/A

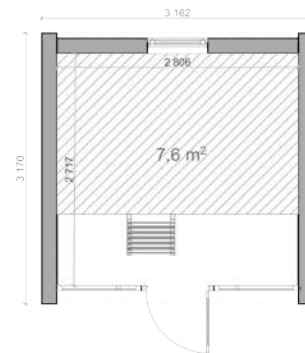

Project specification:

External measures: 3,162x3,17 m Internal attic floor area: 2,5 m²
Internal house area: 7,6 m² Terrace area: 0,5 m²

External wall area: 5,1 m²
Roof area: 31,8 m²

A-frame-32

Article No. N/A

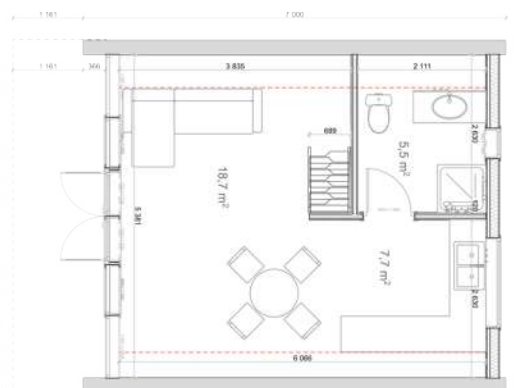

Project specification:

External measures: 5,883x7(+1,16) m Internal attic floor area: 13,9 m²
Internal house area: 31,9 m² Terrace area: 9,1 m²

External wall area: 11,3 m²
Roof area: 89,6 m²

A-frame 39

Article No. N/A

New concept

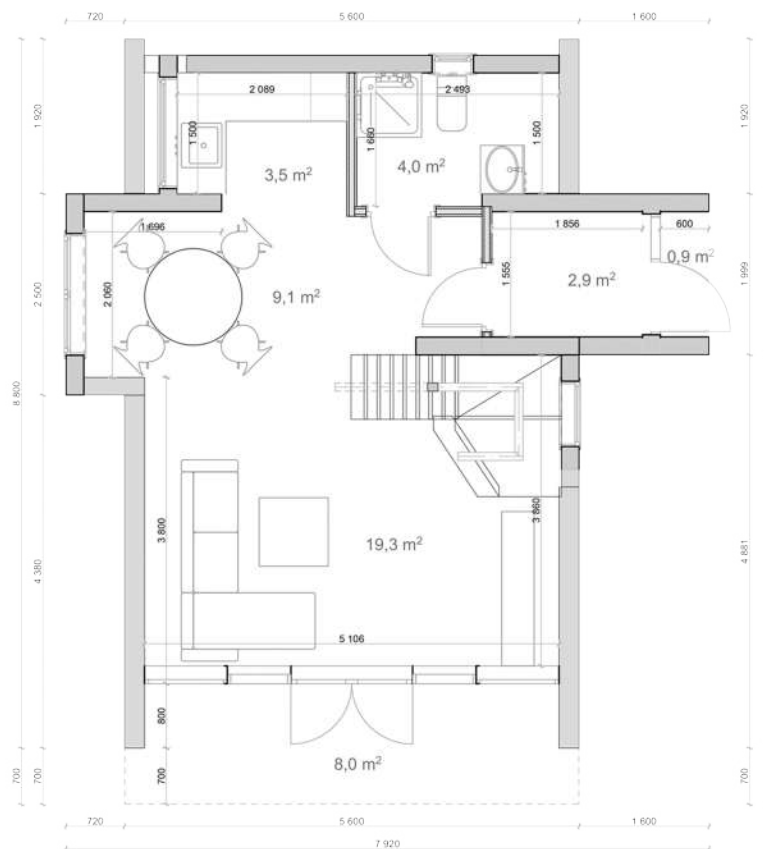

Project specification:

External measures: 5,6(+2,32)x8,8(+0,7) m
Internal house area: 38,8 m²

Internal attic floor area: 12,1 m²
Terrace area: 8,9 m²

External wall area: 47 m²
Roof area: 111 m²

Optional products

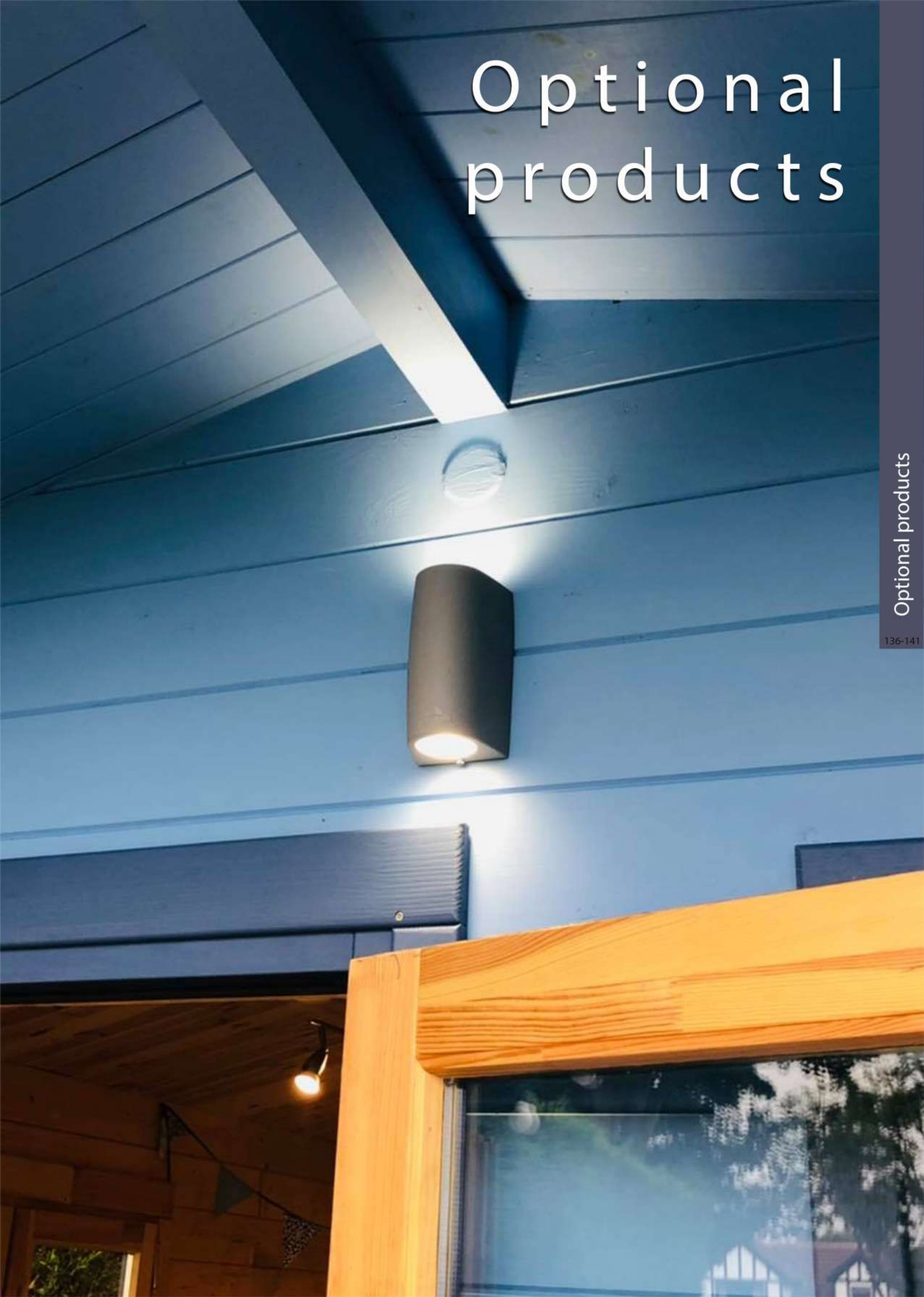



Dipping (pine)

We offer full house dipping in bath of „pine“ colour water-soluble treatment liquide for better protection and durability.

Acrylate-based scrubble concentrate for the industrial coating of wood for outdoor areas, such as garden timber, formwork walings, scaffolding boards.

Properties:

- Highly concentrated;
- Easily soluble in water;
- Fast drying;
- Smooth flow;
- Low grain direction;
- Moisture-regulating;
- Block-resistant;
- Mild odour, odourless after drying.



Bitumen roof tiles

For our convenience we offer bitumen roof tiles with mineral reinforcement, type 6S4X21, produced in accordance with ETA-12/0264 of 30/06/2017. This product intended to be laid as discontinuous covering for pitched roofs and/or wall cladding where the watertightness of the system is ensured by overlapping, according to the manufacturer's installation instructions.

Bitumes tiles are hexagonal shape in several colours (red, green, black, grey, brown).



Underlayer

An additional layer of waterproofing used under bitumen tiles that reliably protects the roof from water leakage and extends the service life of the roof covering. We offer high-quality polymer bitumen that ensures complete tightness at the nail penetration points.

Advantages:

- Lightweight material is easy to install on the slope.
- Non-slip surface ensures safety works on the roof and UV protection.
- High quality bitumen-polymer compound has the property of "self-healing", which gives absolute tightness in places of nail penetration.
- Due to the high heat resistance and flexibility UNDERLAY PRO 500 retains the original properties even when exposed to extreme temperatures.
- Underlayer can be used as a temporary roofing.
- Versatility - material is used on any type of roofing.

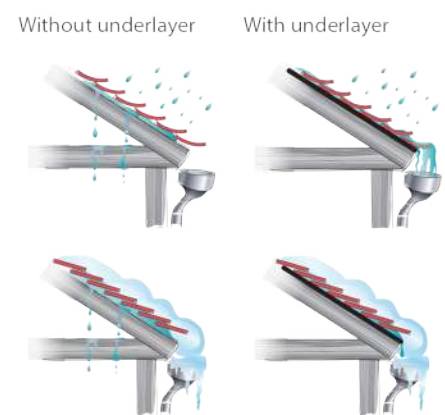

EPDM roof cover

For flat roofs or roofs that are under 7 degrees roof angle we offer rubber roof covering material – EPDM. This cover has long service life, reduces heating costs and potential condensational problems. Perfect solution for flat modern style roofs.



Metal roof cover

According to a project made steel roof tile kit is durable option for two or one slope roofs. Can be supplied different colours.



Raingutters

Raingutter system can be installed on any pitched and one slope roofs, not just steel. The system can be of different colors and can be adapted to various solutions.

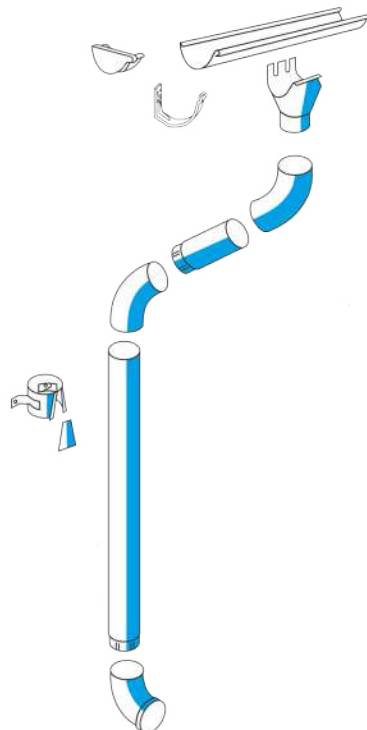

Optional products

136-141

Roof insulation

Roof insulation kit prepared for specific roof is recommended option to make house warmer or to protect house from the heat which appears from direct sunlight.

We offer 2 standard roof insulation options: 10cm and 20cm.

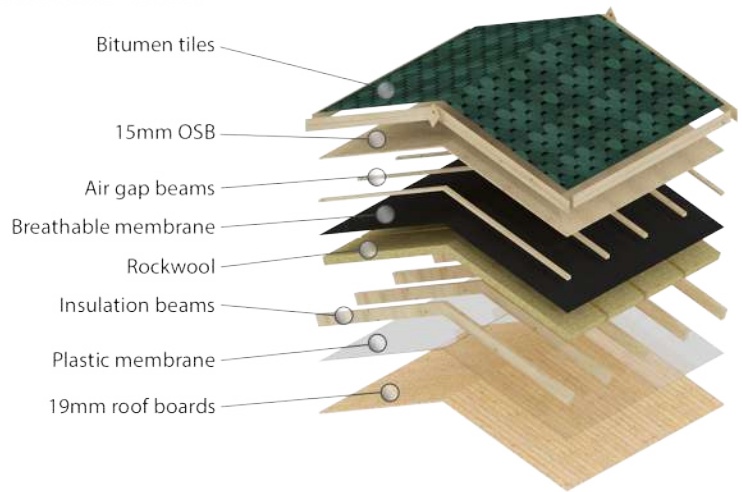

Wall insulation

Outside wall insulation kit prepared for specific house to lower heat losses. Supplied with outside decorative boards.

We offer 2 standard roof insulation options: 10cm and 20cm.

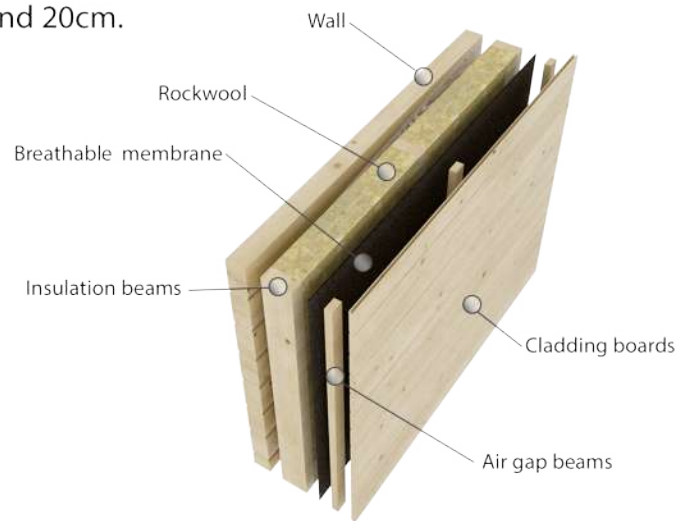

Floor insulation

Floor insulation kit prepared for specific house to offer solution to make floor warmer and protect from cold coming from ground.

We offer 3 standard roof insulation options: 5cm, 10cm and 15cm.

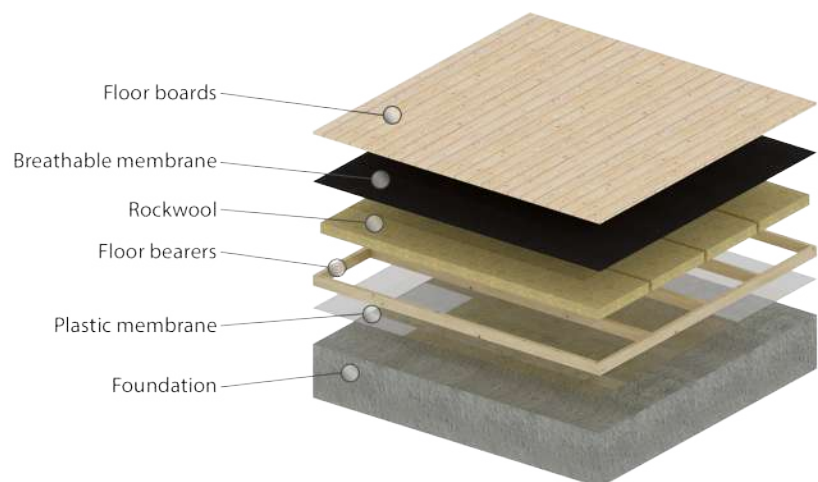

Terrace

1,5m meter depth wooden terrace with impregnated terrace boards and decorative fence can be added to some standard projects to provide some relaxation area.

There are different options of width: 3m, 4m, 5m and 6m. Wall thicknesses can be chosen in 44mm (including 44x60 floor bearers) or 28mm (including 28x60 floor bearers).

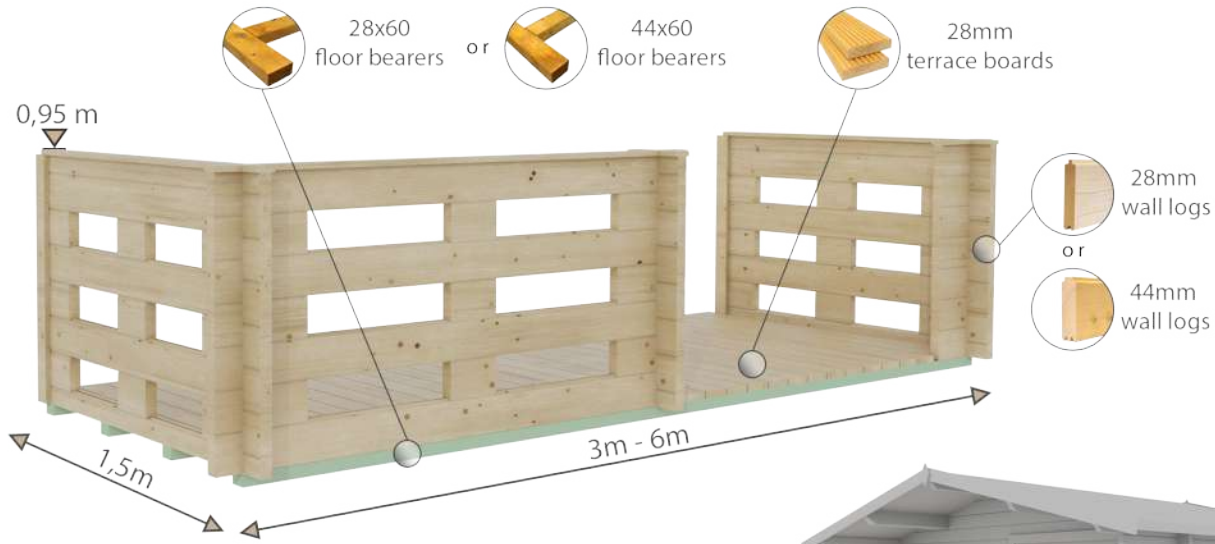

Extra WC 2,2x2,2

2,2x2,2 extension can be added to some standard projects with possibility increase total living area for making WC room. Extra WC extension have additional 1 window (Premium) 0,52x0,5 m and 1 single full wood door (Premium) 1,98x0,85 m with possibility install items in any place.

Extra WC 2,2x2,2 can be 2 options: 44mm (with optional 19mm floor boards) and 68mm (with optional 28mm floor).

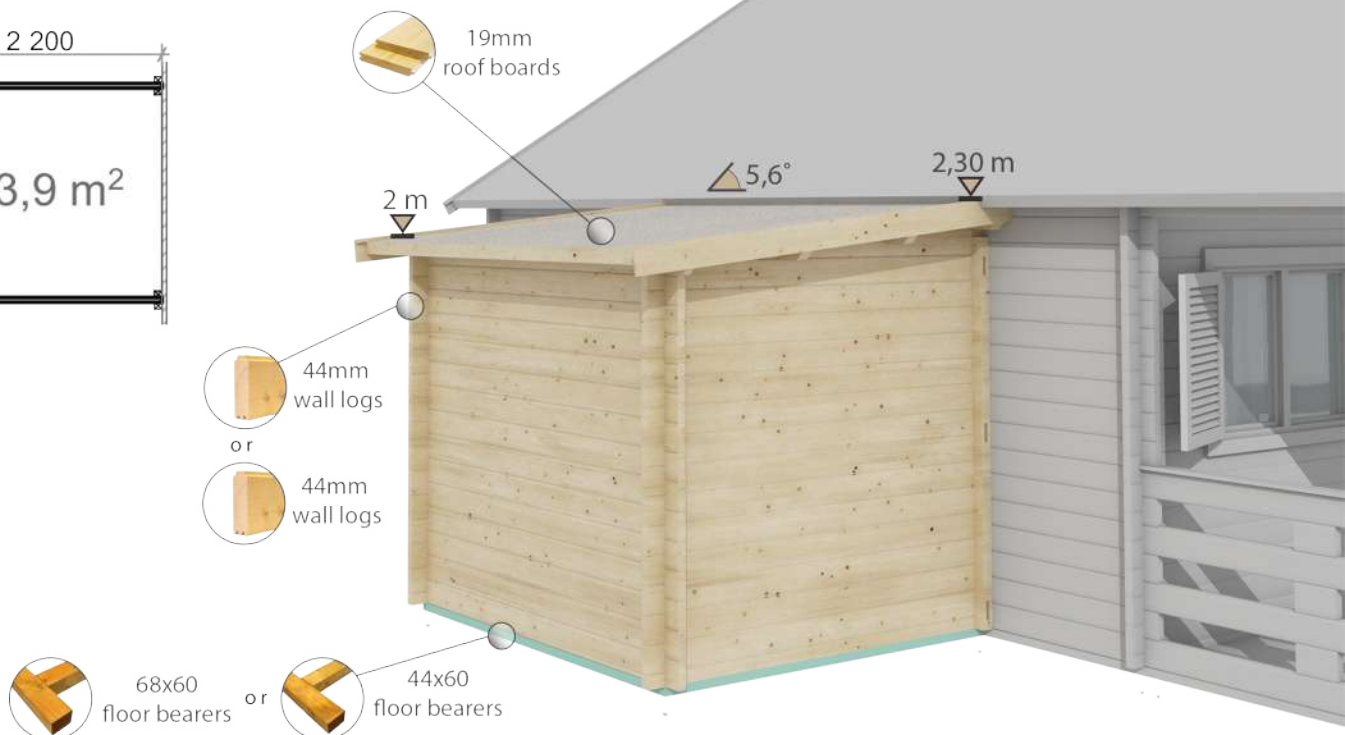
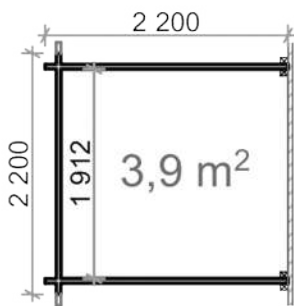

Windows & doors





Economy

versus

Premium

 Hinges for Economy and Premium windows looks the same, but their quality are different.

Hinges

Manual tilt mechanism

Top



Bottom (side)

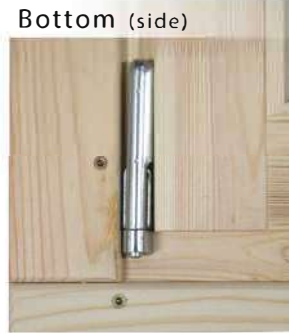



Bottom

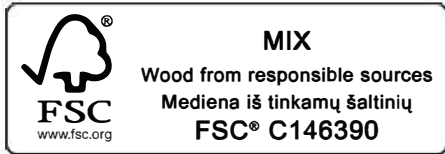

Manual leaf lock mechanism

Certificates



 FSC certificate available for Economy and Premium windows and doors. Ask your sales manager before production.



Standard windows measures

Economy quality

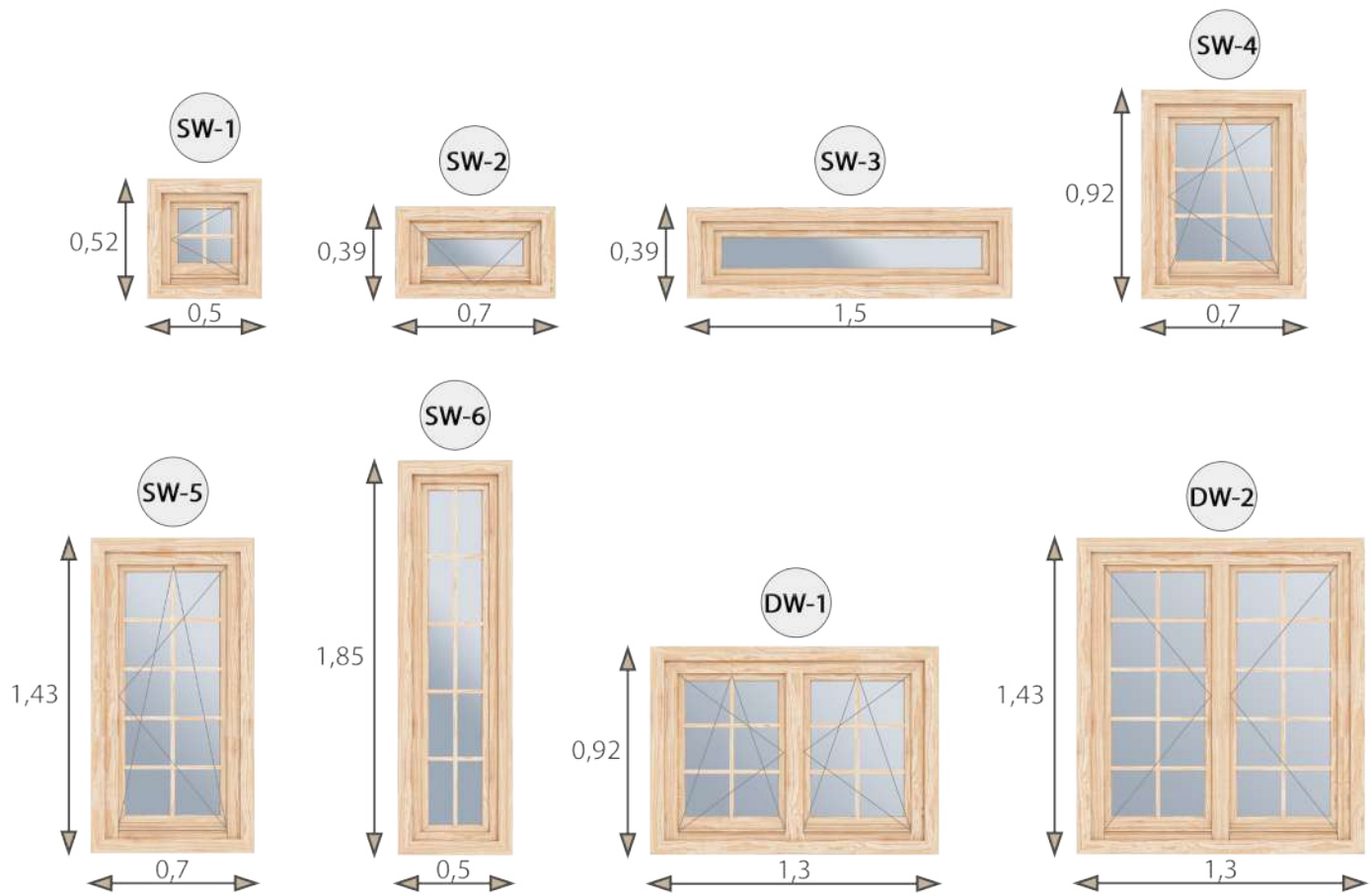

Standard doors

Economy

versus

Premium

Structure

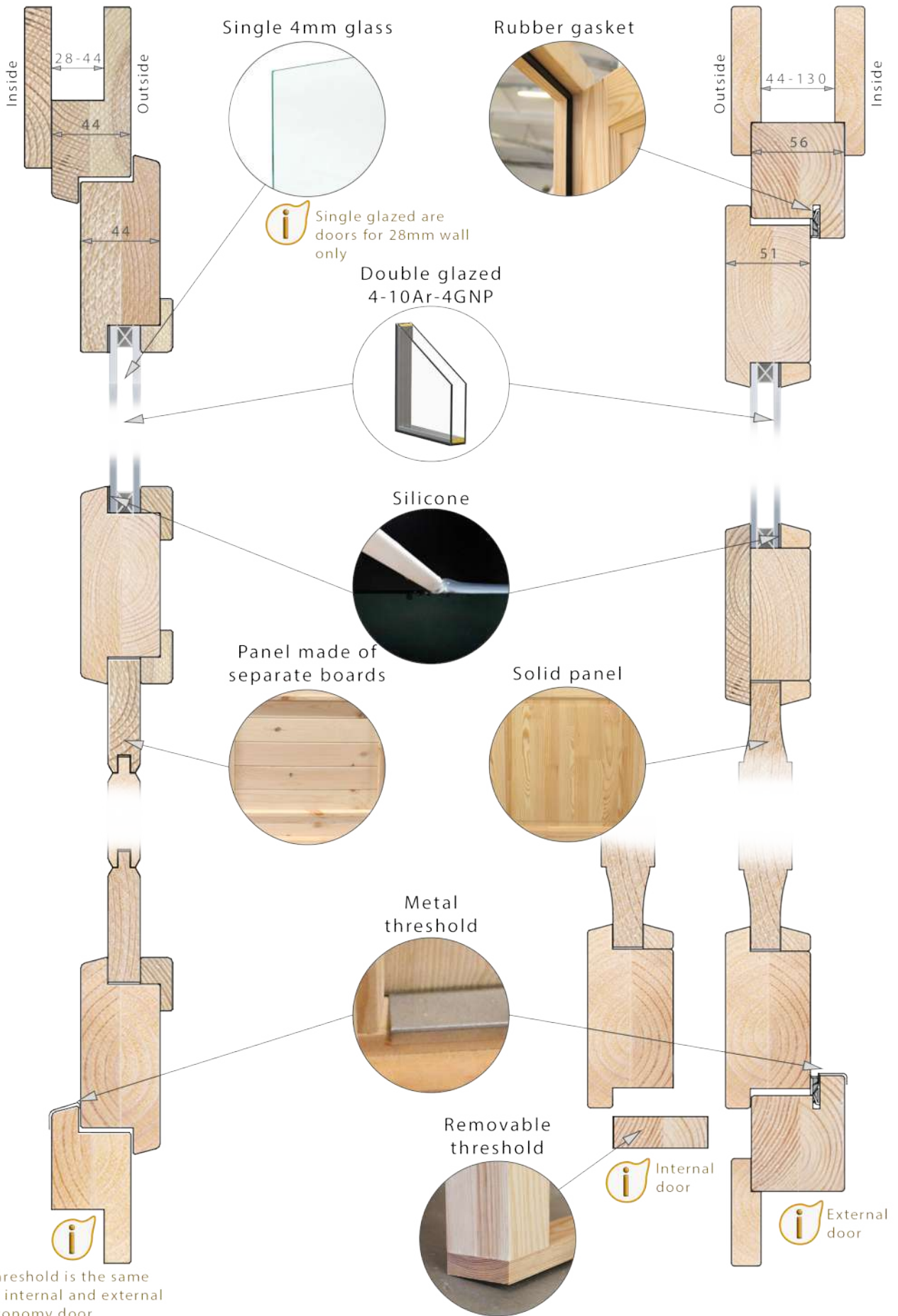

Economy

versus

Premium

i Hinges for Economy and Premium doors are the same.



i Two colors available (for Premium quality only)

Economy "Beta" door handle



Standard door handle

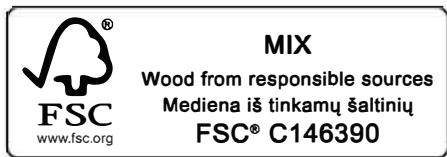

i FSC certificate available for Premium and Premium plus windows and doors. Ask your sales manager before production.



Hinges

Handles

Certificates

Windows&doors

Standard doors measures

Economy quality

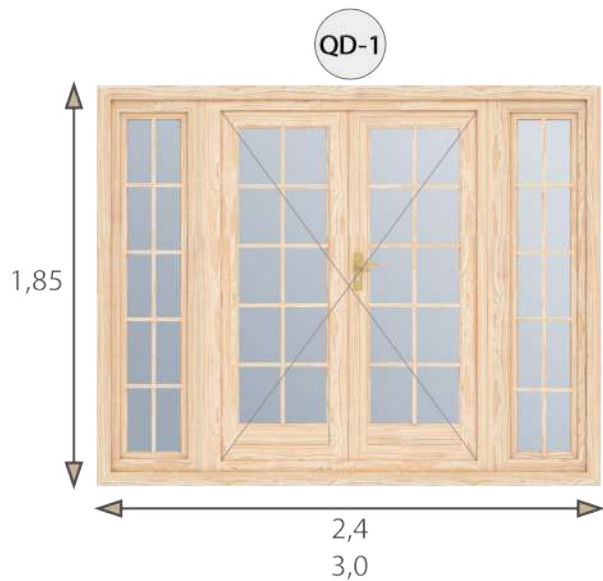
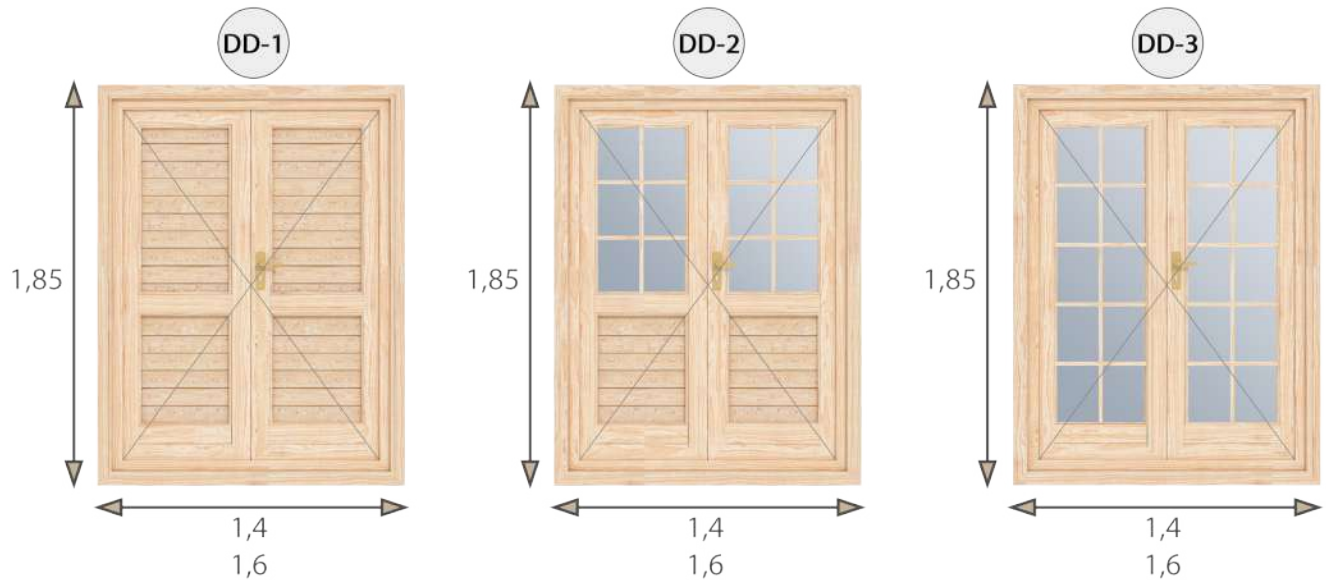
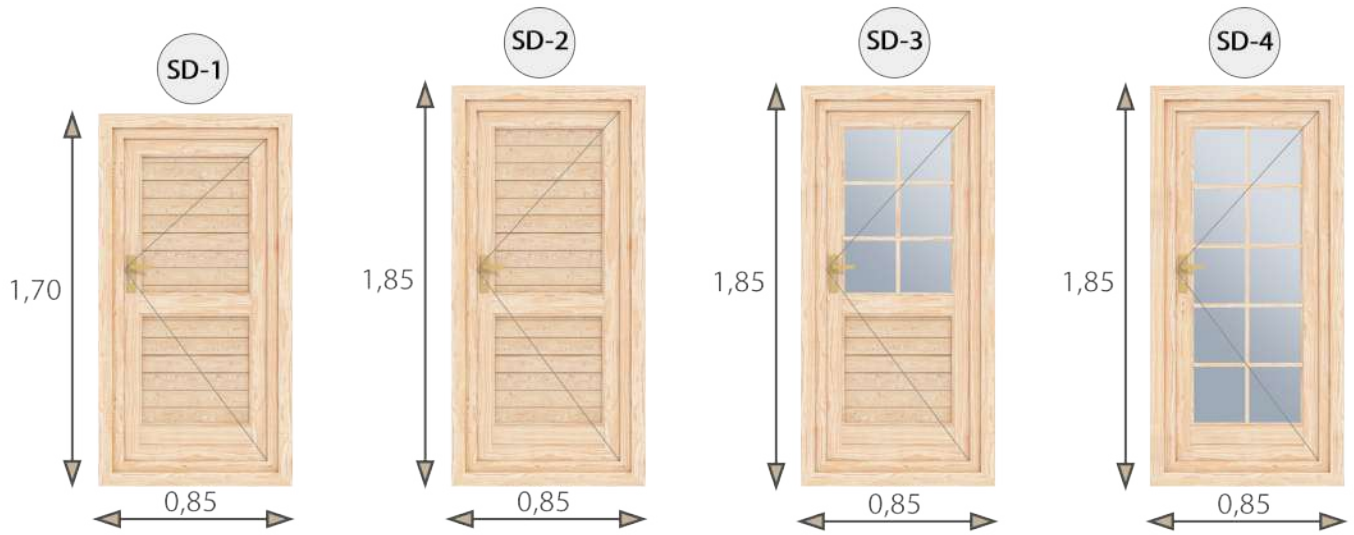

Standard windows

Premium

versus

Premium plus

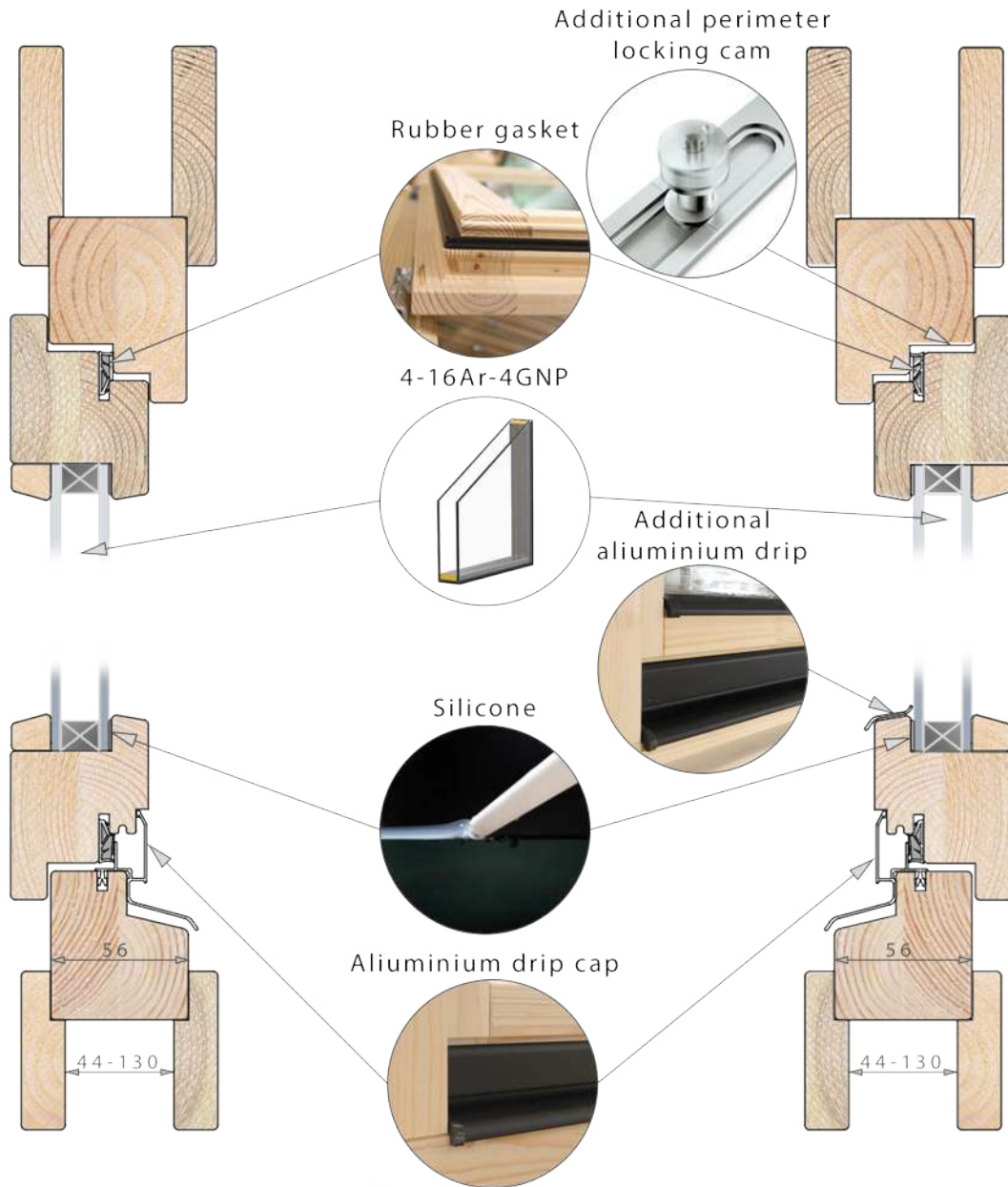

Structure

Roto window handle



for Premium and Premium plus handles are the same

- Basic handle without additional functions
- Lock-in position 90°
- Ten-year performance warranty
- Classification in accordance with DIN EN 13126-3
- Two colours are available



Handle

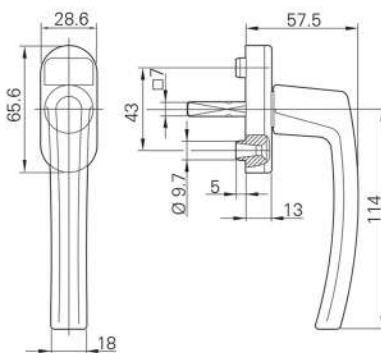

Opening direction using handle:



Premium plus

Premium

Premium

versus

Premium plus

Hinges



Manual tilt mechanism

Manual leaf lock mechanism



Tilt&turn mechanism



Hinges cover kit



Two colors available: silver or gold



 **MIX**
Wood from responsible sources
Mediena iš tinkamų šaltinių
FSC® C146390



FSC certificate available for Premium and Premium plus windows and doors. Ask your sales manager before production.



SCS Global Services does hereby certify that an independent audit has been completed and conformity to the applicable standard(s) has been confirmed for:

This site certificate covers the production and trade of sawn wood for construction, wood shavings and particles using the transfer system

FSC 100%; FSC Mix

Valid from: 18 March 2021 | Expiry date: 12 March 2024





External outward opening composite doors and outward and inward opening windows (Premium plus quality) according to the requirements of BM TRADA A-MARK scheme of Factory Production Control (FPC) detailed in BM TRADA Scheme Technical Document "Verification of FPC according to technical specification" and of EN143251-1:2006+A2:2016

DECLARATIONS OF PERFORMANCE

Identification number: 01_13_0101

Product description:
External opening doors and parts of windows and inward and outward opening windows (Premium plus quality) according to the requirements of BM TRADA A-MARK scheme of Factory Production Control (FPC) detailed in BM TRADA Scheme Technical Document "Verification of FPC according to technical specification" and of EN143251-1:2006+A2:2016

Manufacturer: UAB "Jantus" (Lithuania)

System of assessment and verification of conformity of performance (AVCP system): 1

Notified Authority: 01_13_0101, UAB "Tinkama Technologija" (Lithuania)

Declared Performance:

Essential Characteristics	Performance	Minimum Technical Specifications
Resistance to axial load	Class 3	EN 12227
Resistance to wind load	Class 3	EN 12227
Resistance to impact	Class 3	EN 12227
Resistance to fire	Class 3	EN 12227
Acoustic performance	Class 3	EN 12227
Thermal performance	Class 3	EN 12227
Water performance	Class 3	EN 12227
Structural strength	Class 3	EN 12227
Normal performance	Class 3	EN 12227
Fire performance	Class 3	EN 12227

The performance of the product described in points 1 and 2 is in conformity with the declared performance in point 3. The minimum of performance is equal with the minimum of the corresponding technical specification in point 4.

Signature: [Signature]

Date: 2021.03.18

 **bmtrada**

REGISTRATION CERTIFICATE

This is to approve

External outward opening composite doors and outward and inward opening windows according to the requirements of the BM TRADA A-MARK scheme of Factory Production Control (FPC) detailed in BM TRADA Scheme Technical Document "Verification of FPC according to technical specification" and of EN143251-1:2006+A2:2016

The certificate was first issued on 18 March 2021 and will remain valid until the next audit or until the certificate is cancelled.

Signature: [Signature]

Date: 2021.03.18

Windows&doors

Certificates

Standard windows measures

Premium & Premium plus quality

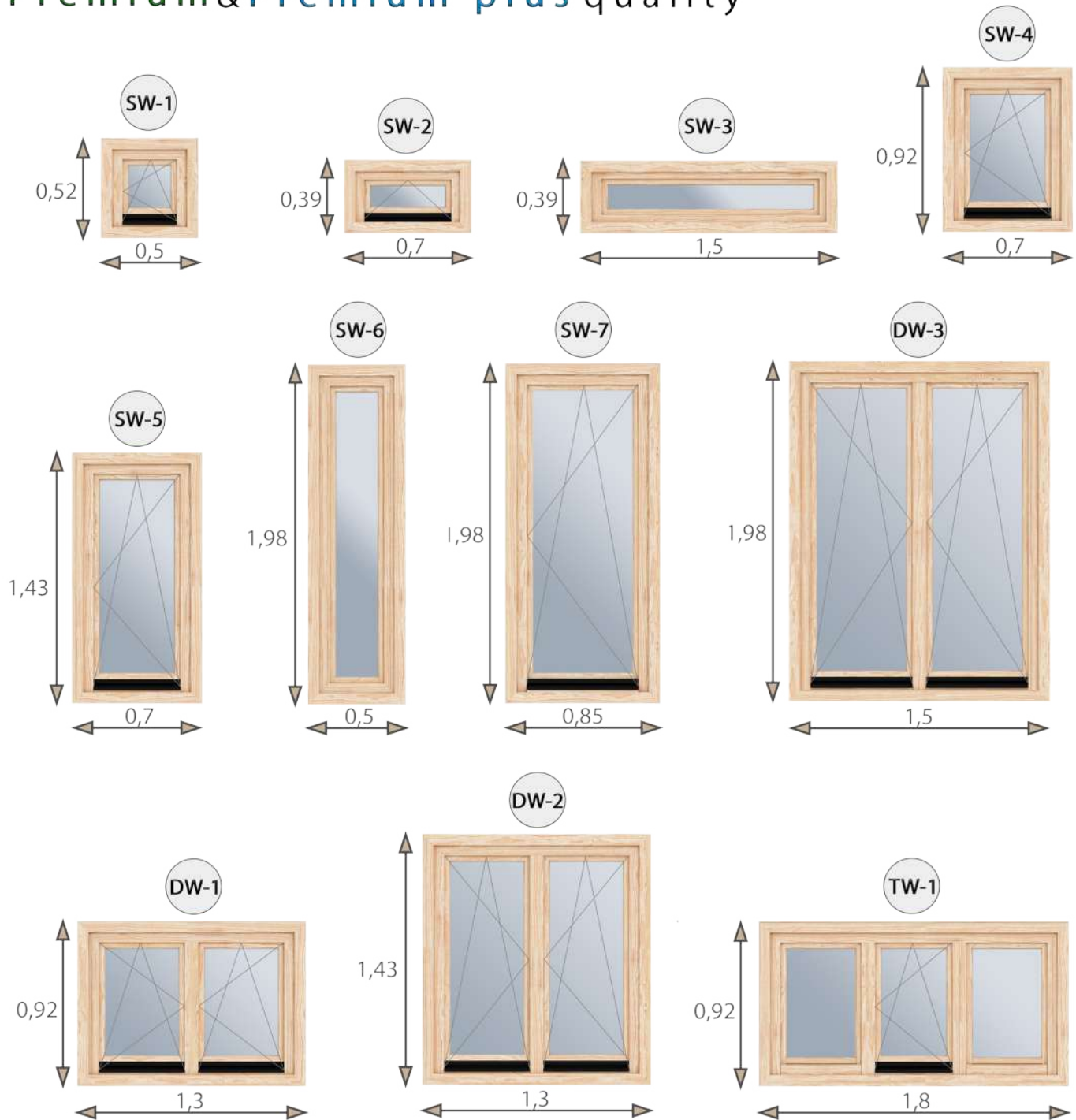

i Note: windows SW-1, SW-7 and DW-3 are shown as Premium plus quality. Premium quality windows turn only.

Special windows *

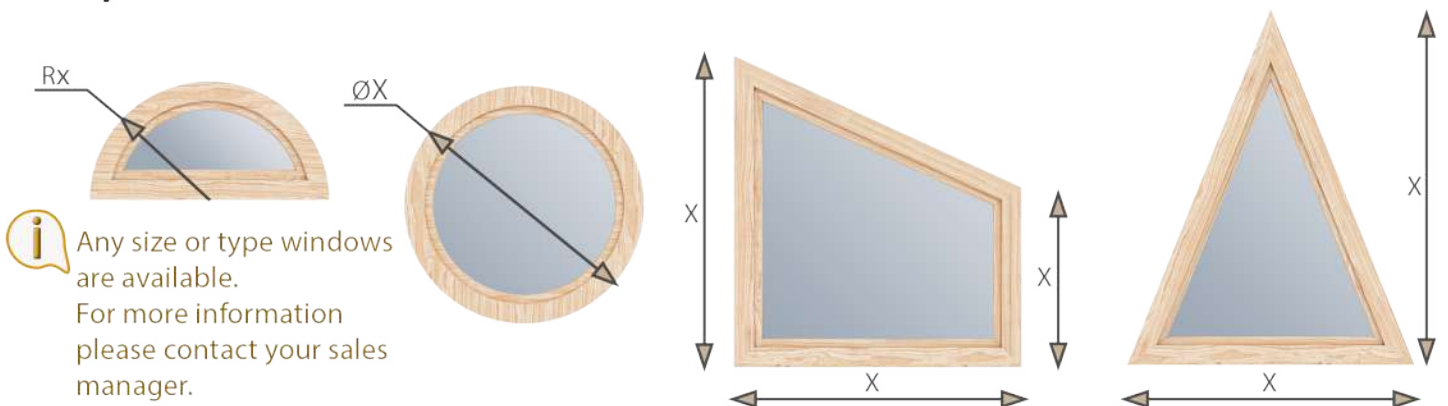

i Any size or type windows are available. For more information please contact your sales manager.

Standard doors

Premium

versus

Premium plus

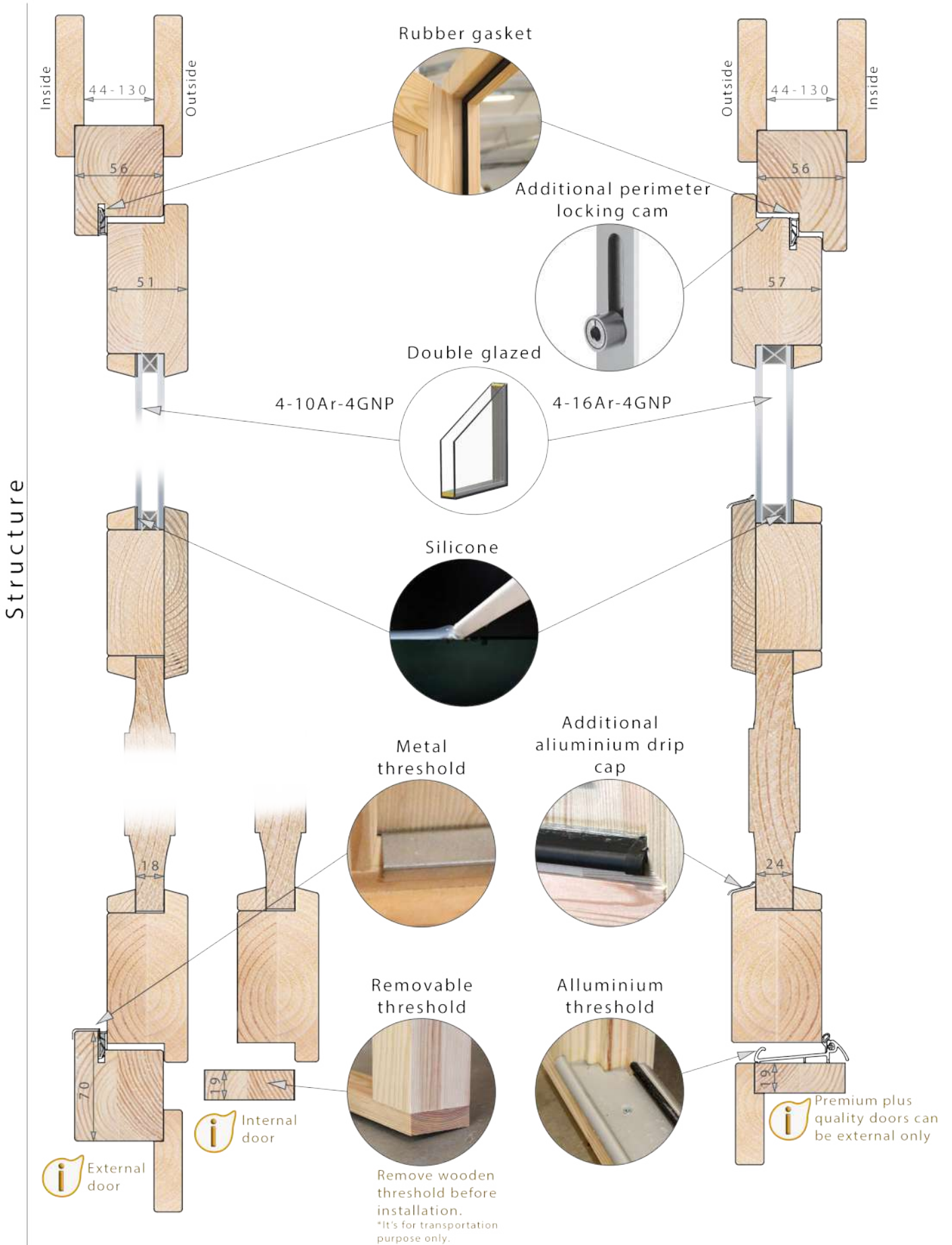

Standard doors measures

Premium & Premium plus quality

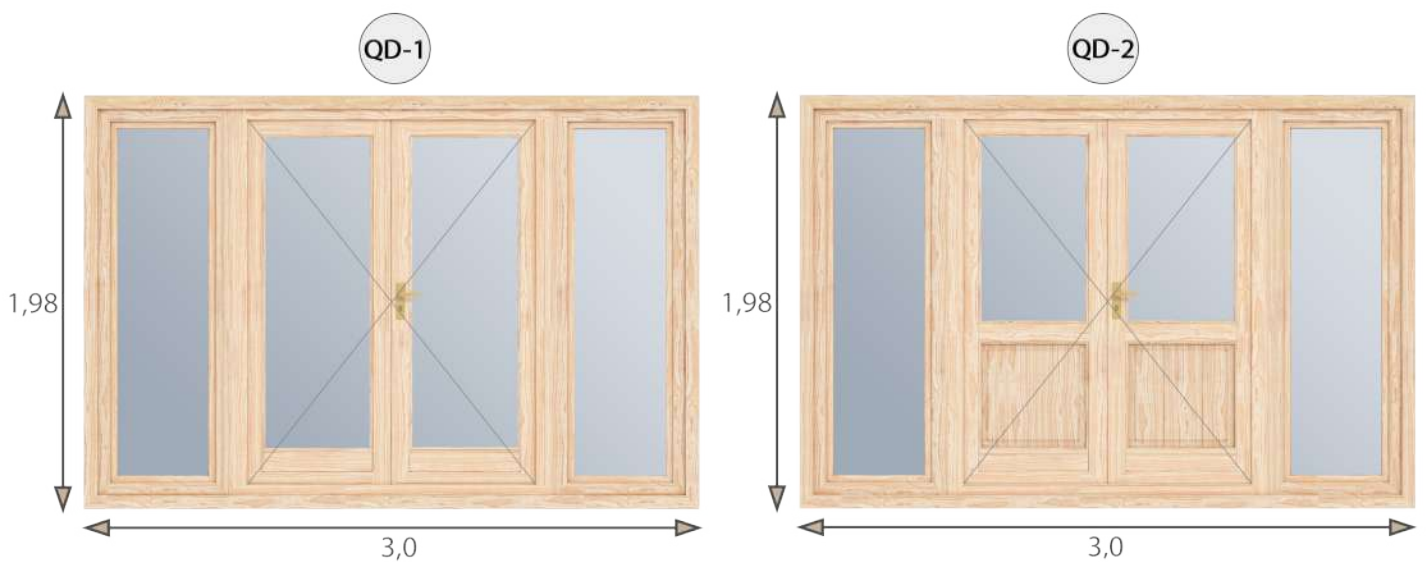
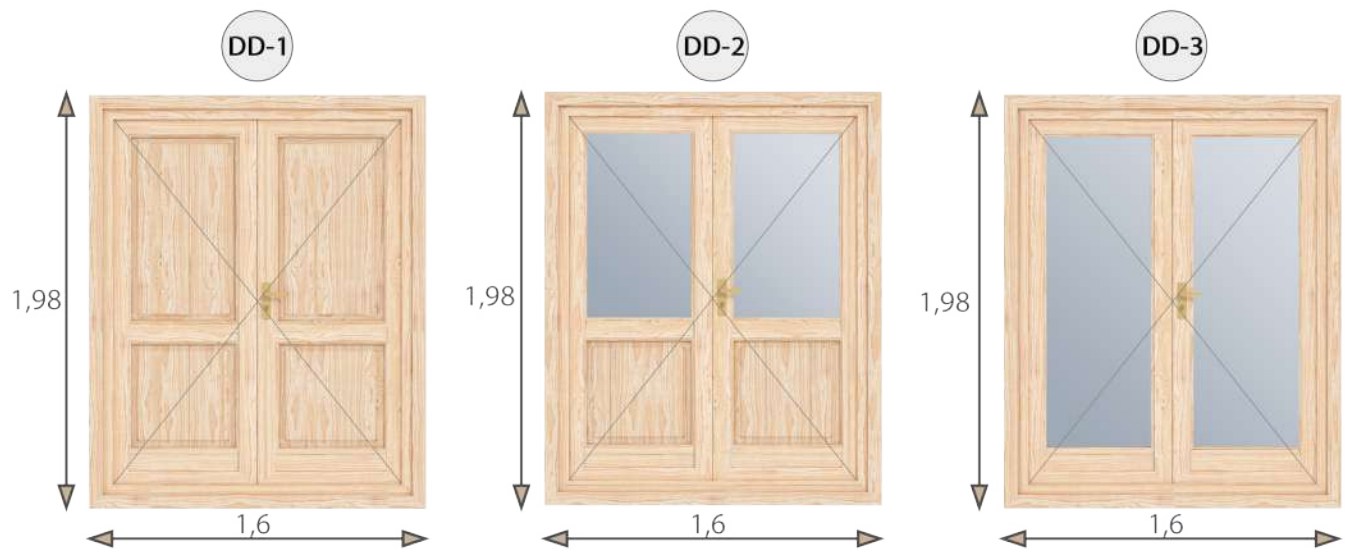
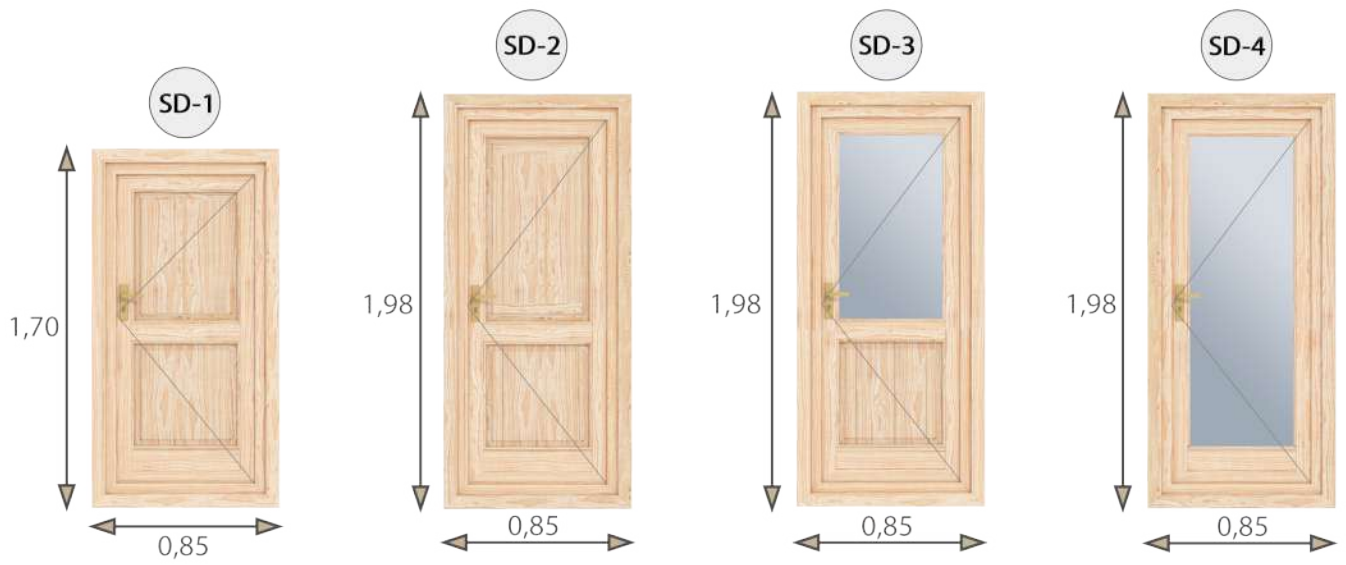

Windows and doors

Standard and custom measures (Economy, Premium and Premium plus)

Note: Color for door handles and painting is available if buying at least 3 houses.



*Custom ID	Measures of frame (HxW)	Possible quality	Opening type	Handles (pcs)	*Color of handles	*Painting
SW-1	520x500	Economy/Premium/Premium plus	Turn (tilt&turn Premium plus only)	1	●	●
SW-2	390x700	Economy/Premium	Top hung	1	●	●
SW-3	390x1500	Economy/Premium	Fixed	0	●	●
SW-4	920x700	Economy/Premium/Premium plus	Tilt&turn	1	●	●
SW-5	1430x700	Economy/Premium/Premium plus	Tilt&turn	1	●	●
SW-6	1850x500	Economy	Fixed	0	●	●
SW-6	1980x500	Premium	Fixed	0	●	●
● SW-6	2180x500	Premium	Fixed	0	●	●
SW-7	1980x850	Premium/Premium plus	Turn (tilt&turn Premium plus only)	1	●	●
● SW-7	2180x850	Premium/Premium plus	Turn (tilt&turn Premium plus only)	1	●	●
DW-1	920x1300	Economy/Premium/Premium plus	Tilt&turn	2	●	●
DW-2	1430x1300	Economy/Premium/Premium plus	Tilt&turn	2	●	●
DW-3	1980x1500	Premium/Premium plus	Turn (tilt&turn Premium plus only)	2	●	●
● DW-3	2180x1500	Premium/Premium plus	Turn (tilt&turn Premium plus only)	2	●	●
TW-1	920x1800	Premium/Premium plus	Tilt&turn	1	●	●
SD-1	1700x850	Economy/Premium	Full wood	1	●	●
SD-2	1850x850	Economy	Full wood, 50% or 100% glass	1	●	●
SD-2	1980x850	Premium/Premium plus	External, full wood, 50% or 100% glass	1	●	●
SD-2	1980x850	Premium	Internal (no threshold), full wood	1	●	●
● SD-2	1980x1040	Premium	External, full wood, 50% or 100%	1	●	●
● SD-2	1980x1040	Premium	Internal (no threshold), full wood	1	●	●
● SD-2	2180x850	Premium/Premium plus	External, full wood, 50% or 100% glass	1	●	●
● SD-2	2180x850	Premium	Internal (no threshold), full wood	1	●	●
● SD-2	2180x950	Premium/Premium plus	External, full wood, 50% or 100% glass	1	●	●
● SD-2	2180x950	Premium	Internal (no threshold), full wood	1	●	●
● SD-2	2180x1040	Premium/Premium plus	External, full wood, 50% or 100% glass	1	●	●
● SD-2	2180x1040	Premium	Internal (no threshold), full wood	1	●	●
DD-1	1850x1400	Economy	Full wood, 50% or 100% glass	1	●	●
DD-1	1850x1600	Economy	Full wood, 50% or 100% glass	1	●	●
DD-1	1980x1600	Premium/Premium plus	Full wood, 50% or 100% glass	1	●	●
● DD-1	2180x1600	Premium/Premium plus	Full wood, 50% or 100% glass	1	●	●
QD-1	1850x2400	Economy	100% glass	1	●	●
QD-1	1850x3000	Economy	100% glass	1	●	●
QD-1/QD-2	1980x3000	Premium/Premium plus	50% or 100% glass (side panels are 100%)	1	●	●
● QD-1/QD-2	2180x3000	Premium/Premium plus	50% or 100% glass (side panels are 100%)	1	●	●

Standard windows

HQ-living quality

From the beginning of 2023 we offer high quality wooden windows and doors. It's the best option for living houses.

- System: 78-EURO.
- 4GN-14T-4-14T-4 tripple glazed with Argon gas.
- Locks and fittings: Siegenia.
- Gaskets: Deventer.
- Microventilation, drainage from Aluron.
- High quality "Remmers" painting will protect wood from water and atmospheric effects.
- Any size and structure of windows and doors can be produced.

Water tightness, class LST EN 12208:2002 9A
 Air permeability, class LST EN 12207:2017 4

Structure

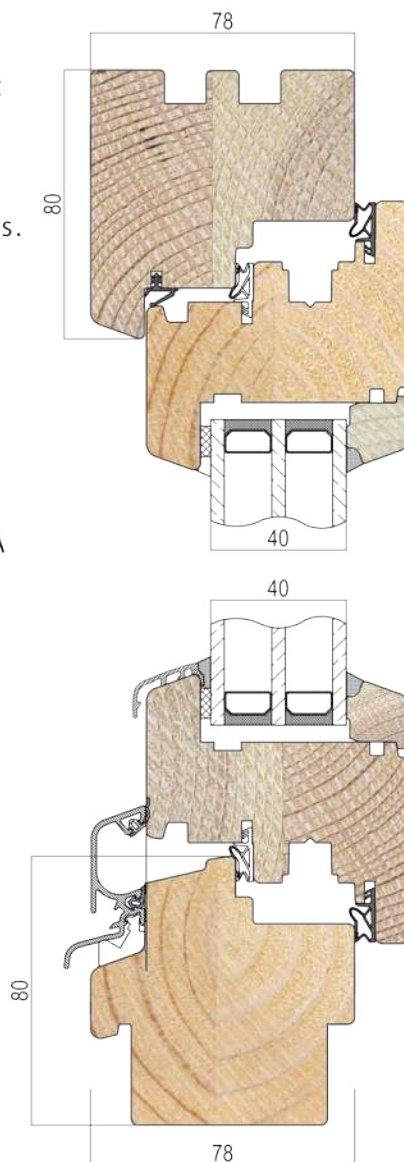

Roto window handle

- Basic handle without additional functions
- Lock-in position 90°
- Ten-year performance warranty
- Classification in accordance with DIN EN 13126-3
- Eight colours are available

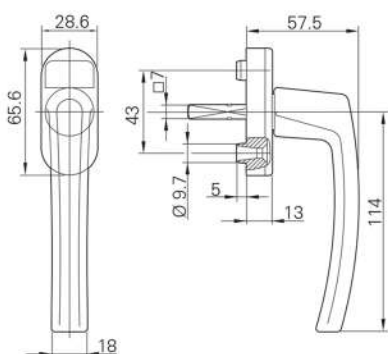

Handle

Colour palette "Remmers"

Perlweiß



Transparent



Graubeige



Gelborange

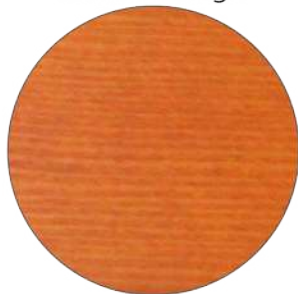

Orangebrown

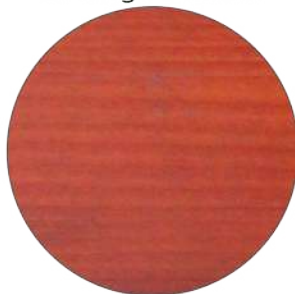

Oxidrot

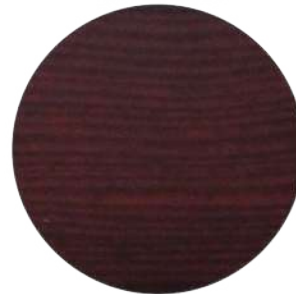

Rehbrown



Khakigräu



Olivegräu

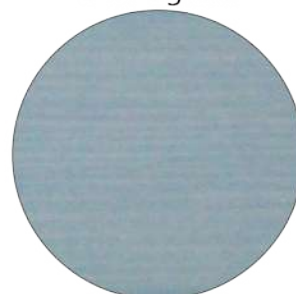

Zementgräu

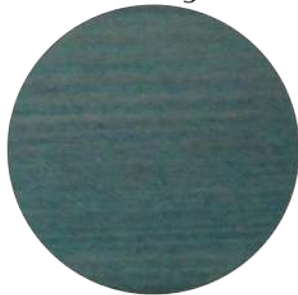

Graphitegräu



This palette it's colour idea. Colours can look different according to peculiarity of wood or your screen/print resolution.





Contact reseller